

الجمهورية الجزائرية الديمقراطية الشعبية
PEOPLE'S DEMOCRATIC REPUBLIC OF ALGERIA
وزارة التعليم العالي والبحث العلمي
MINISTRY OF HIGHER EDUCATION AND SCIENTIFIC RESEARCH
جامعة -البليدة-1
UNIVERSITY SAAD DAHLEB- BLIDA 1



Faculty of Technology
Department of Civil Engineering
Laboratory Geomaterials and Civil Engineering

MASTER DISSERTATION

Speciality: Materials in civil engineering

THEME

**PERFORMANCE OF MORTAR BASED ON LIGHTWEIGHT
EXPANDED CLAY AGGREGATES**

By

Chetouani Selma et Meghnoudj Imene

Jury:

Dr. Bensaci Hamza	U.S.D.B.1	Chairman
Pr. Menadi Belkacem	U.S.D.B.1	Examiner
Dr. Yahiaoui Walid	U.S.D.B.1	Supervisor
Pr. Kenai Said	U.S.D.B.1	Co-Supervisor

Blida, July, 2022.

Acknowledgements

First of all, we would like to thank Allah, the merciful for having given us the will, the strength and the courage to accomplish this modest work.

We would like to thank our supervisor Dr Yahiaoui Walid for having supervised, helped and advised us.

Our thanks to professor Kenai Said co-supervisor and director of geo-materials and civil engineering at university of Blida 1 for his advice and support.

We are also very grateful to madam Bentlmsen Nadia lecturer at university of Blida 1 for her advices.

Our heartfelt thank also go to members of the jury professor Menadi Belkacem and Doctor Bensaci Hamza for the interest they have shown in our research by agreeing to examine our work.

We would like to thank the entire ALGEXPAN team, who provided us with lightweight sand for the development of our research work.

Finally, we thank all the crews and technicians who worked in laboratory of the university Blida 1 for their help and availability throughout our work.

DEDICATION

I dedicate this humble work to my dear mother “Ghania” my life and happiness, my model of sacrifice at the source of my efforts who encouraged me through all my studies and always available to help me, I love you mom.

My dear father “Mourad” who is always available to support me and encourage. Thanks to you dad I love you so much.

To my second mother “Leila” Thank you as have not ceased to encourage me and pray for me that god bless you.

To my one adorable “Ouiam” sister and my dear brother “Zakaria” for their constant encouragement, guidance, moral support and prayers.

To my late grandfather “Tassaaditte” I hope that GOD keep you in his vast paradise.

To my cousin “Hanane” I love you my best friend and to my great friends “Nawel, Dhikra, Sarah, Bouchra, Nerdjes and Nihad”.

To my dear partner my best friend “Selma” Thank you for your patience, your tolerance, your sympathy, Thank you for all the moments spent together and you gave me everything for success.

Meghnoudnj imene.

I dedicate this modest work to my mother «Alima» who encouraged me during all my studies, and who is always available to help me. I confirm my attachment to her and my deep respect.

To my father «Mohammed», who is always available to support me and so that I can reach this stage.

To my dear sisters «Marwa», «Nessrine», «Hanene» who have always been at my side to encourage me.

To my dear friends especially «Dounia» who helped and supported me in difficult times.

To my dear partner «Imene» and to all her family.

To all my friends from my class.

And to everyone I knew during my study cycle.

Chetouani Selma.

Abstract

This dissertation is devoted to study the performance of ordinary mortar and self-compacting mortar by incorporation lightweight expanded clay aggregates. Various amounts of substitution of natural sand by lightweight expanded clay fine aggregates were used 0%, 25%, 50% and 75%, The performance of mortar was investigated at the fresh state as well as in the hardened state.

The results showed that the substitution of sand by expanded clay aggregates resulted in a mortar with low density. This mortar is also characterized by low thermal conductivity and hence can be used in the thermal insulation of buildings.

Keywords: ordinary mortar, self-compacting mortar, lightweight aggregate, expanded clay, thermal conductivity.

Résumé

Cette mémoire est consacrée à l'étude de la performance du mortier ordinaire et autoplaçant par incorporation des granulats légers d'argile expansée, Différents niveaux de substitution du sable naturel par des granulats d'argile expansée ont été utilisés avec divers pourcentage 0%, 25%, 50% et 75%, l'analyse de ce mortier a été faite à l'état frais ainsi qu'à l'état durci. Les résultats de l'étude ont montré que la substitution partielle ou totale du sable par des granulats d'argile expansée résulte dans un mortier de faible masse volumique ayant une faible conductivité thermique et par conséquent peut être utilisé dans l'isolation thermique des bâtiments.

Mots clés : mortier ordinaire, mortier autoplaçant, granulats légers, argile expansée, conductivité thermique.

ملخص

هذه الرسالة مخصصة لدراسة أداء الملاط العادي والمضغوط ذاتيًا من خلال دمج الركام الطيني الممدد الخفيف، وقد تم استخدام مستويات مختلفة من استبدال الرمل الطبيعي بالركام الطيني الممدد بنسب مختلفة 0% 25% 50% 75%

تم تحليل الملاط في الحالة الطازجة وكذلك في الحالة المتصلبة وأظهرت نتائج الدراسة أن الاستبدال الجزئي أو الكلي للرمل بواسطة ركام الطين الممدد أدى إلى انخفاض كثافة الملاط مع الموصلية الحرارية المنخفضة وبالتالي يمكن استخدامها في العزل الحراري للمباني.

الكلمات المفتاحية ملاط مضغوط ذاتيًا، حصى خفيف الوزن، طين ممدد

Summary

Acknowledgements

DEDICATION

GENERAL INTRODUCTION	16
1 Chapter 1 LITTERTAURE REVIEW	18
1.1 Introduction	18
1.2 History of lightweight aggregates production.....	18
1.3 Lightweight aggregates	19
1.3.1 Masonry lightweight aggregate :	19
1.3.2 Insulating aggregate :.....	19
1.4 Different types of lightweight aggregates	20
1.4.1 Natural lightweight aggregates	20
1.4.1.1 Pumice	20
1.4.1.2 Scoria	21
1.4.1.3 Pozzolan.....	21
1.4.1.4 Diatomite	22
1.4.1.5 Vermiculite	22
1.4.2 Artificial lightweight aggregate	23
1.4.2.1 Expanded clay.....	23
1.4.2.2 Expanded shale	23
1.4.2.3 Expended perlite	24
1.4.3 By Product lightweight aggregate.....	24
1.4.3.1 fly ash	24
1.4.3.2 Blast furnace slag.....	25
1.4.3.3 Waste glass	25
1.4.3.4 Bricks waste.....	25

1.4.3.5	Silica fume	25
1.4.3.6	Silica aerogels.....	25
1.4.3.7	Palm oil shells.....	26
1.5	Production of Lightweight Aggregates	26
1.6	Chemical and mineralogical composition of lightweight aggregates	26
1.6.1	Artificial aggregates.....	26
1.7	Characteristics of lightweight aggregates	27
1.7.1	Density	27
1.7.1.1	Bulk density	27
1.7.1.2	Actual density	27
1.7.2	Water absorption and water-accessible porosity	28
1.7.2.1	Water absorption.....	29
1.7.2.2	Porosity accessible to vacuum water	29
1.7.2.3	Porosity measured by mercury intrusion	30
1.7.3	Mechanical properties	30
1.7.3.1	Conventional strength.....	31
1.7.3.2	Bulk crushing.....	31
1.7.3.3	Hydrostatic strength (bursting pressure).....	31
1.7.3.4	Tensile strength.....	31
1.7.4	Elastic properties of lightweight aggregates	31
1.8	Thermal conductivity	32
1.9	Shrinkage.....	32
1.10	Effective water content and water to cement ratio	32
1.11	Difference between lightweight aggregate concrete and normal weight concrete	33
1.12	Expanded clay aggregates	34
1.12.1	Clay aggregate manufacturing process	35

1.12.1.1	LECA manufacturing techniques	35
1.12.2	Properties of LWA manufactured using clay	36
1.13	Application domain and advantages	37
1.14	The mortar.....	37
1.15	Mortar consistency	38
1.15.1	Water.....	38
1.15.2	Cement.....	38
1.15.3	Sand	38
1.15.4	Admixtures.....	39
1.15.5	The additives	39
1.16	Classification of mortars	39
1.16.1	Bulk density	39
1.16.1.1	Heavy mortars:	39
1.16.1.2	Lightweight mortars :	39
1.16.2	Nature of application	39
1.16.2.1	Bricklaying mortars:.....	40
1.16.2.2	Finishing mortars:.....	40
1.17	Types of mortar.....	40
1.17.1	Based on binding materials.....	40
1.17.1.1	Cement mortar:	40
1.17.1.2	Lime mortar:	40
1.17.1.3	Refractory mortar:	41
1.17.1.4	Quick mortar:.....	41
1.17.1.5	Industrial mortar:	41
1.18	Manufacture of mortar	41
1.18.1	Handcrafted.....	41

1.18.2	Mechanical manufacturing	41
1.19	Use of mortar.....	41
1.19.1	Masonry hourdage	41
1.19.2	Coatings	42
1.19.3	Screeds.....	42
1.19.4	Seals and wedges	43
1.20	Effect of lightweight aggregates on mortar.....	43
1.20.1	Bricks	43
1.20.2	Diatomite	44
1.20.3	Waste Plastic Particles	44
1.20.4	Scoria	44
1.20.5	Perlite	45
1.20.6	Fly ash.....	45
1.20.7	Pumice	46
1.20.8	Waste glass	46
1.21	Conclusion.....	49
2	Chapter 2: Experimentation and test program.....	50
2.1	Introduction	50
2.2	Characteristics of the materials used.....	50
2.2.1	Lightweight aggregate	50
2.2.2	Cement.....	54
2.2.3	Mixing water.....	54
2.2.4	Admixtures.....	54
2.2.5	Sand	55
2.2.5.1	Absolue density	55
2.2.5.2	Bulk density.....	56

2.3	Gradings of the sands used.....	58
2.4	Formulation of mortar.....	58
2.5	Composition of self-compacting mortar.....	59
2.5.1.1	Fresh state of self-compacting mortar.....	60
2.5.2	Composition of ordinary mortar.....	62
2.5.2.1	Fresh state of ordinary mortar:.....	63
2.6	Hardened state tests of mortars.....	64
2.6.1	Preparation and curing of the specimens.....	64
2.6.2	Tensile strength by bending.....	65
2.6.3	Compressive strength test (NF EN 12390-3).....	65
2.6.4	Thermal conductivity.....	66
2.6.5	Drying shrinkage (ASTM C596-09).....	67
2.6.6	Capillary absorption (ASTM C1585-11).....	68
2.7	Summary of the tests carried out.....	69
3	Chapter 3 : RESULTS AND DISCUSSIONS.....	71
3.1	Introduction.....	71
3.2	Mini cone test.....	71
3.3	Spread test.....	72
3.4	Density.....	72
3.5	Air content.....	74
3.6	Drying shrinkage.....	76
3.7	Compressive and flexrual strength.....	76
3.8	Thermal conductivity.....	80
3.9	Water capillary absorption.....	82
3.10	Conclusion.....	83
	GENERAL CONCLUSION.....	83

List of figures

Figure 1.1: Rome's Coliseum	Figure 1.2: Pantheon in Rome.....	19
Figure 1.3: Pumice stone		21
Figure 1.4: Scoria rock		21
Figure 1.5: Pozzolan rock		22
Figure 1.6: Diatomite rock.....		22
Figure 1.7: Expanded clay		23
Figure 1.8: Expanded shale.....		24
Figure 1.9: Fly ash		24
Figure 1.10: Two principal moisture conditions of light weight aggregates		33
Figure 1.11: Lightweight aggregate manufacturing process flowchart and typical clay end product		36
Figure 1.12: Schematic of an ideal pore structure (left) and typical pore structure of clay LWA (right)		37
Figure 1.13: Mortar laying.....		42
Figure 1.14: Insulating plasters and facade plasters		42
Figure 1.15: Fluid screeds and cement screed		42
Figure 1.16: Sealing's		43
Figure 1.17: Capillarity water absorption for brick waste-based mortars		44
Figure 1.18: Effect of expanded perlite fineness modulus on the compressive strength....		45
Figure 1.19: Slump cone test results after 150 s		47
Figure 1.20: The impact of glass cullet ratio on the density of mortar with GSA.....		47
Figure 1.21: Compressive and flexural strength depending on GSA ratio.....		48
Figure 1.22: Compressive and split tensile strength of samples with GSA depending on GSA content.....		48
Figure 2.1: The factory	Figure 2.2: Factory logo	50
Figure 2.3: Raw material	Figure 2.4: The raw material deposit.....	51

Figure 2.5: Clay crushed	Figure 2.6: The mixing.....	52
Figure 2.7: Rotary kilns		52
Figure 2.8: Screening.....		53
Figure 2.9: Silos.....		53
Figure 2.10: Bulk density		57
Figure 2.11: Grading curve of Boughezoul sand 0/3.....		58
Figure 2.12: Grading curve for expanded clay sand 0/3 (crushed).....		58
Figure 2.13: Mortar mixing sequence.....		60
Figure 2.14: Density in the fresh state		60
Figure 2.15: Mortar v-funnel test apparatus		61
Figure 2.16: Aerometer.....		62
Figure 2.17: Mortar mixing sequence.....		63
Figure 2.18: Spread test		63
Figure 2.19: Principle of operation of the workability meter		64
Figure 2.20: Prismatic specimens mould (40x40x160) mm		64
Figure 2.21: Tensile strength by bending test.....		65
Figure 2.22: Compressive strength test		66
Figure 2.23: Thermal conductivity test.....		67
Figure 2.24: Extensometer and specimens with demec gauges.....		68
Figure 2.25: Specimens with resin.....		69
Figure 3.1: Spread of self comapcting mortar (SCM)		71
Figure 3.2 : Spread of ordinary mortar (OM)		72
Figure 3.3 : Density of mortar mixes		73
Figure 3.4: Density of mortar mixes.....		74
Figure 3.5: Air content of SCM.....		75
Figure 3.6: Air content of OM.....		75

Figure 3.7: Drying shrinkage of SCM	76
Figure 3.8: Compressive strength of self-compacting mortar	77
Figure 3.9: Flexural strength of SCM.....	77
Figure 3.10: Compressive strength of ordinary mortar mixes.....	78
Figure 3.11: Flexrual strength of ordinary mortar mixes.....	79
Figure 3.12: Thermal conductivity	80
Figure 3.13: Thermal conductivity of ordianry mortar mixes	81
Figure 3.14: Capillary water absorption of SCM	82

List of table

Table 1-1 : Chemical composition of lightweight aggregates of expanded clay and shale aggregates[13].....	27
Table 1-2: Application and domain and advantage of LWA.....	37
Table 2-1: The different fractions obtained	51
Table 2-2 : Physical characteristics of Lafarge cement CEMII/B 42.5 N.....	54
Table 2-3: Chemical composition of Lafarge cements CEMII/B 42.5 N.....	54
Table 2-4 : Mineralogical composition of Lafarge cements CEMII/B 42.5 N.....	54
Table 2-5: Characteristics of the admixture.....	55
Table 2-6: Densities and percentage of humidity of sand.....	56
Table 2-7: Bulk density of samples	57
Table 2-8: Characterization of sands	57
Table 2-9: Self-compacting mortars mixes.....	59
Table 2-10: Ordinary mortar formulation.....	62
Table 3-1: Results of density of SCM.....	73
Table 3-2: Results of density of ordinary mortar.....	73
Table 3-3: Results of air content of self-compacting mortar	74
Table 3-4 : Results of air content for ordinary mortar	75
Table 3-5: Results of compressive strength of SCM	76
Table 3-6: Results of flexural strength of self-compacting mortar.....	77
Table 3-7: Results of compressive strength of ordinary mortar	78
Table 3-8: flexural strength of ordinary mortar mixes.....	78
Table 3-9: Results of thermal conductivity of self-compacting mixes.....	80
Table 3-10: Results of thermal conductivity of ordinary mortar mixes.....	81

Abbreviation list

CA: Crushed aggregate

DT: Diatomite

EP: Expanded perlite

ES: Sand equivalent

GSA: Glass sand aggregate

LCPC: The central laboratory for bridges and roads

LECA: Lightweight expanded clay aggregate

LS: Light sand

LWA: Lightweight aggregate

LWAC: Lightweight aggregate concrete

NA: Nodular aggregate

NWA: Normal weight aggregate

NWC: Normal weight concrete

OM: Ordinary mortar

SCM: Self-compacting mortar

SF: Silica fume

V: Vermiculite

W/C: Water cement ratio

GENERAL INTRODUCTION

Today is the era of innovations in construction technology. The development of advanced materials and applications of modern techniques have been an active area of research. One of these areas is the development of insulating masonry mortars such as lightweight mortar. Expanded clay aggregates are known for their greatest compressive strength among lightweight aggregates is expanded clay aggregates. and are available in the region of Blida. Expanded clay it characterized by its low density (300 and 700 kg/m³), high porosity and low thermal conductivity (approximately 0.10 W/m. K). This material has been used in construction due its high physical and chemical stability and low cost.

In practice, the inclusion of expanded clay aggregates in concrete or mortar mixes as an entire or partial replacement for aggregate is of growing interest. This reduces the demand on natural resources for construction materials and provides multiple alternatives to the traditional ingredients of concrete mixes.

Lightweight cement mortar can be used for underwater construction, tunneling, airports, soil stabilization, roads and in tall buildings, Lightweight cement for better heat resistance, eco-friendly construction. in tall building construction and This Lightweight mortar can also be used as fire resistant, and soundproof material.

Quarry aggregate extraction has a significant environmental impact, such as deforestation and the change of the terrain of a massif and landscape; the extraction of alluvial aggregates cause the water table to drop drying of the soil around these rivers. These two extraction processes have The European Union's Member States and the European.

In Algeria, the legislation has become very strict against all extractions. Thus, to preserve the environment, it has become essential to find new Aggregate sources that can provide alternative solutions.

The objective of this dissertation is to propose an ordinary and self-compacting lightweight mortar with partial or total natural sand substitution by locally available expanded clay fine aggregates for various applications in masonry for better heat insulation.

The dissertation is composed of three chapters.

Chapter 1 provides background information pertinent to lightweight aggregate and lightweight mortar.

Chapter 2 describes the experimental program used for this project and presentation of the factory ALGEXPAN.

Chapter 3 presents the results of the experimental tests and their discussion especially the influence of crushed expanded clay aggregate on the physico-mechanical characteristics of ordinary mortar and self-compacting mortar.

Finally, we conclude this work with a general conclusion highlighting the main results achieved is given and some future work is proposed

1 Chapter 1 LITTERTAURE REVIEW

1.1 Introduction

This chapter focuses on the different types of lightweight aggregates, the basic physical, chemical and mechanical properties of lightweight aggregates and the effect of lightweight expanded clay aggregates on mortar performance.

1.2 History of lightweight aggregates production

The use of lightweight aggregates dates back to roman times, which is between 27 BC christ and 476 AD. Several buildings, to mention only the pantheon and the Colosseum in Rome, were made in part in mortar or light concrete (Figures 1 and 2). For example, the dome of the pantheon with a span of approximately 43 meters was made with materials of varying densities including one containing pumice stone.

After the decline of the Roman empire, the use of natural lightweight aggregates such as pumice stone, pozzolan, diatomite, etc..., were slowed down until the advent of lightweight artificial aggregates such as expanded clay, expanded slate and fly ash sintered in the 20th century.

Historically, engineer Hayed Stephen was the first to manufacture lightweight aggregates by applying a heat treatment to an expandable material. Arnould and Virgleux filed a patent in 1918 for the expansion technique clay, slate and shale from a rotary kiln. This is the beginning of the production and marketing of artificial lightweight aggregates.

In France, interest in artificial lightweight aggregates developed in the early 1970's with the establishment of the first factory in Watten in the north.

Lightweight aggregates are present today in different fields such as building (precast concrete and ready-mixed concrete), public works (backfill), horticulture (garden graining), water treatment (filter or bacterial bed). Some are weak or even reliable while others are resistant and hard [1].

Earlier lightweight aggregate (LWA) were of natural origin, mostly volcanic (pumice, scoria, tuff, etc.). These have been used both as fine and coarse aggregate. They function as active pozzolanic material when used as fine aggregate. They interact with calcium hydroxide generated from the binder during hydration and produce calcium silicate hydrate which strengthens the structure and modifies the pore structure, enhancing the durability

properties. Pumice mine has been used first by Greek and later by Romans long before Cristianism [2].



Figure 1.1: Rome's Coliseum



Figure 1.2: Pantheon in Rome

1.3 Lightweight aggregates

Lightweight aggregate is the generic name of a group of aggregates having a relative density lower than normal density aggregates (natural sand, gravel, and crushed stone), sometimes and is referred to as low density aggregate, with a particle density of less than 2000 kg/m^3 unlike traditional aggregates or a dry loose bulk density of less than 1200 kg/m^3 is defined as lightweight, the decrease in densities is due to high porosity of the noted lightweight aggregates.

Lightweight aggregates are those minerals naturel rock materials, products, and by- products of manufacturing processes that are used as bulk fillers in lightweight structural concrete, concrete masonry units, precast concrete structural products, road-surfacing materials, plaster aggregates, and insulation fill.

1.3.1 Masonry lightweight aggregate :

Aggregate with bulk density less than 1120 kg/m^3 for fine aggregate and less than 880 kg/m^3 for coarse aggregate. This includes aggregates prepared by expanding, pelletizing, or sintering products such as blast-furnace slag, clay, diatomite, fly ash, shale, or slate; aggregates prepared by processing natural materials such as pumice, scoria, or tuff; and aggregates derived from and products of coal or coke combustion.[3]

1.3.2 Insulating aggregate :

Nonstructural aggregate this includes perlite with a bulk density between 120 and 192 kg/m^3 , and vermiculite with a bulk density between 88 and 160 kg/m^3 .

1.4 Different types of lightweight aggregates

Based on the origin of lightweight aggregates there is naturel, artificial, the remainder are waste or synthetic products. They are divided into three categories:

- A. Those occurring naturally and are ready to use only with mechanical treatment, crushing and sieving natural rock as pumice and scoria aggregate, tuff, and volcanic cinders.
- B. Artificial lightweight aggregates such as expanded clay, foamed slag, blast furnace slag, expanded slate, expanded shale.
- C. By-products, resulting from manufacturing processes, or other waste products prepared by crushing and sizing foamed and granulated slag, organic cinders. Other by-product lightweight aggregates in use include coal combustion by-products (fly ash and bottom ash).

1.4.1 Natural lightweight aggregates

The naturally porous aggregates, the most encountered are pumice stones or sedimentary rocks such as limestone extracted from deposits, by crashing them, we therefore obtain light aggregates in the natural state, they have low densities.

The vegetable aggregates they are organic waste that can be recycled in the construction sector we have wood bamboo.

1.4.1.1 Pumice

These are volcanic aggregates and are formed when the SiO₂-rich molten lava cools. The molten magma has plenty of air and gases which get entrapped during sudden cooling of the magma. This makes the aggregates porous (Figure 1.3). The sudden cooling does not allow the crystallization of the minerals, so it attains glassy structure [4].

Pumice contains up to 75 percent silicon dioxide (SiO₂) in chemical composition. As general the chemical composition of pumice as follows:

- 45% - 75% SiO₂
- 13% - 21% Al₂O₃
- 1% - 7% Fe₂O₃
- 1% - 11% CaO
- 7% - 9% Na₂O- K₂O volcanic rock glass [2].

The reasons to be preferred of pumice to use as a raw material in construction sector are as follows:

- Low unit volume weight

- High thermal and sound insulation
- High resistance to fire
- High resistance to freeze-thaw effects
- High resistance to climatic effect [2].

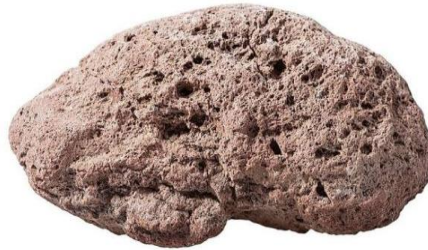

Figure 1.3: Pumice stone

1.4.1.2 Scoria

Scoria has created of accumulation of volcanic ashes and slightly cooling accompanied with bubbles because of vapor and exist gases (Figure 1.4). This scoria have white to light gray color with irregular open and close pores and rough surface and angular particles [5].



Figure 1.4: Scoria rock

1.4.1.3 Pozzolan

A pozzolana is a natural or artificial material containing silica in a reactive form (Figure 1.5). By themselves, pozzolanas have little or no cementitious value. However, in a finely divided form and in the presence of moisture they will chemically react with alkalis to form cementing compounds. Pozzolanas must be finely divided in order to expose a large surface area to the alkali solutions for the reaction to proceed. Examples of pozzolanic materials are volcanic ash, pumice, opaline shales, burnt clay and fly ash. The silica in a pozzolana has to be amorphous, or glassy, to be reactive. Fly ash from a coal-fired power station is a

pozzolana that results in low-permeability concrete, which is more durable and able to resist the ingress of deleterious chemicals [6].



Figure 1.5: Pozzolan rock

1.4.1.4 Diatomite

Diatomite (DT), is a naturally occurring mineral basically composed by hydrated amorphous silica ($\text{SiO}_2 \cdot n\text{H}_2\text{O}$) (Figure 1.6). It comes from the fossilised skeletal remains of the diatom, a kind of unicellular alga. On their particle surface, silanol ($\text{Si}-\text{OH}$) and siloxane ($\text{Si}-\text{O}-\text{Si}$) groups were identified. $\text{Si}-\text{OH}$ acts as a proton donor, while $\text{Si}-\text{O}-\text{Si}$ acts as a proton acceptor. When DT is used as supplementary material in concrete and mortar, it might show a filling effect, and the properties in the plastic and hardened state (cohesion, bleeding and efflorescence) can be improved. However, its skeletal microstructure demands high water content, which is harmful for the strength and durability of concrete [7].

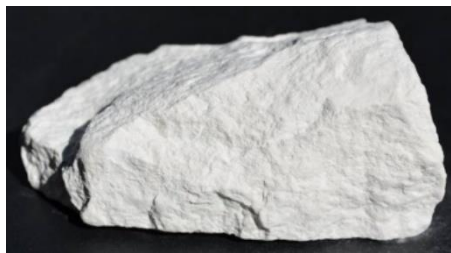

Figure 1.6: Diatomite rock

1.4.1.5 Vermiculite

Vermiculite (V), is a naturally occurring mineral, of chemical composition consists of a complex hydrated aluminum and magnesium silicate. Upon heating, V can expand 8–20 times from its original thickness. V has low bulk density, low thermal conductivity, and chemical inertness make V satisfactory for many types of thermal and acoustic insulations. For this, V can be used as a good additive in lightweight aggregate. Concrete with a low thermal conductivity has a better fire resistance, for instance, lightweight concrete stands up better to fire than ordinary concrete [7].

1.4.2 Artificial lightweight aggregate

They are made of raw materials from industrial by-products of fly ash and blast furnace slag, rice husk ash, granite powder. We can distinguish artificial products from natural raw materials and industrial by-products. Materials produced from natural raw materials are mainly expanded clay, expanded shale etc. These materials are produced by expanding raw materials in a furnace after heating to melting (1000-1300°C). The production of aggregates is done by molding or crushing after calcination or crushing after expansion. The usual manufacturing procedures are expansion in a rotary kiln or cooking on grids.

1.4.2.1 Expanded clay

Lightweight expanded clay aggregates are produced in a rotary kiln by a wet process, using bloating clay. They are made by mixing clay and water into a paste. The paste is fed into the higher end of the rotary kiln where it is broken into smaller granules by chains. Thus, they form aggregates of random size and shape while passing through the rotary kiln where they are sintered to a glassy material (Figure 1.7). The aggregates that come out of the kiln are sieved to different sizes [4].

Expanded clay is characterized by its low density (300 and 700 kg/m³), high porosity and low thermal conductivity (approximately 0.10 W/m·K). This material has been used in construction due to its high physical and chemical stability and low cost [8].



Figure 1.7: Expanded clay

1.4.2.2 Expanded shale

It is a lightweight material produced by firing mined lumps of shale at high temperatures in a rotary kiln in a process similar to that of clay ceramics (Figure 1.8). The resulting product can be screened to create various size fractions depending on the intended use. From smallest to largest, 0.07 to 15.9 mm [9].



Figure 1.8: Expanded shale

1.4.2.3 Expanded perlite

Expanded perlite is a granular porous material that is produced by heat expansion of raw perlite at temperatures ranging about from 850 °C to 1150°C. Raw perlite rock is composed from amorphous volcanic glass that contains some bound water. The material at high temperatures softens and expands up to about 16 times of its original volume by the action of pressure of water vapors released from the glass. Due to the extreme porosity the expanded perlite has a very low bulk density, excellent thermal insulation and sound insulation properties. It is also chemically inert, non-flammable, resistant to water [7].

1.4.3 By Product lightweight aggregate

A waste material like heavy metal sludge, mining residues, palm shell, paper sludge, pet bottles, sewage sludge, steel slag, bottom ash, fly ash, marine clay.

1.4.3.1 fly ash

Fly ash is a by-product of a thermal power station (Figure 1.9). The quality of the fly ash depends upon components of the burning process such as the temperature and heating rate. Experience has shown that the fly ash varies from the day shift to the night shift in the same thermal power station. These factors influence the carbon content and the particle size. It can also vary the calcium content [4].



Figure 1.9: Fly ash

1.4.3.2 Blast furnace slag

In the manufacture of steel, pig iron is produced together with slag. The amount by volume of slag produced is about the same as pig iron. The quantity of slag thus produced is very large, and it creates ecological and environmental problems. Some slag is used after granulating and grinding as cement replacement material in the building industry. Apart from this, some of it is used in making lightweight aggregate [4].

1.4.3.3 Waste glass

Glass is a transparent material formed by melting a mixture of materials such as silica, soda ash, and CaCO_3 at high temperature followed by cooling during which solidification occurs without crystallization. When waste glass is crushed to sand-like particle sizes, similar to that of natural sand, it exhibits properties of an aggregate material.

There are two types of waste glasses; colored and colorless. Most colorless waste glasses are recycled effectively, colored waste glasses with their low recycling rate are generally dumped into landfill sites [10].

1.4.3.4 Bricks waste

Brick is one of the most common masonry units as a building material due to its properties. It has the widest range of products, with its unlimited assortment of patterns, textures and colors. The main raw material for bricks is clay besides clayey soils, soft slate and shale, which are usually obtained from open pits with the attendance of disruption of drainage, vegetation and wildlife habitat [11].

1.4.3.5 Silica fume

Silica fume (SF) is a waste material produced from fabrication of silicon/alloys including silicon in electric arc furnaces. Purity of quartz drops at a temperature of about 2000 °C and generates silicon dioxide (SiO_2) vapors that further oxidize and condense at low temperature to generate SF. It is also produced as a waste material from the fabrication of other silicon alloys for example- ferro-magnesium, ferro- chromium, ferro-manganese and calcium-silicon. SF can be treated as a pozzolanic material as it has high fineness with high silica content [12].

1.4.3.6 Silica aerogels

Silica aerogels are inorganic nano-structured materials, highly porous, with densities between 3 and 500 kg/m^3 and with excellent thermal properties (thermal conductivity

between 0.01 W/m. K and 0.02 W/m. K). These characteristics meet the actual demands of energy saving and noise reduction [8].

1.4.3.7 Palm oil shells

Agriculture wastes, which are renewable, present an interesting alternative to the traditional and sometimes to imported building materials, particularly for low-cost construction. The material properties and structural performance of lightweight aggregate concrete with palm oil shells as aggregates are similar to the lightweight concrete produced using the more common aggregates such as clinker, and expanded clay. The palm oil shells are hard and are received as crushed pieces as a result of the process used for extracting the oil. The workability and compressive strength of lightweight concrete with palm oil shells as aggregates is affected by the proportion of palm oil shells and the water-to-cement ratio [4].

1.5 Production of Lightweight Aggregates

Lightweight aggregate can be occurred naturally or produced by thermal treatment. For the aggregate occurred naturally, the aggregate is ready to be use only after the mechanical treatment which include crushing and sieving. Some industrial by-products, waste materials, naturally occurring materials, etc., thermal treatments are applied in order to make them as aggregate.

The properties of lightweight aggregate concrete depend on the properties of the aggregate used, which in turn depend on the type of the material and the producing process to produce these aggregates. In lightweight aggregate concrete, there is a vast variation in the density of the aggregate, thus, there will be a vast variation in the strength of the lightweight aggregate concrete.

1.6 Chemical and mineralogical composition of lightweight aggregates

1.6.1 Artificial aggregates

Aggregates made from expanded clay, expanded shale and fly ash have similar chemical composition, they are composed of more than 85% silica, alumina and iron oxide. Quartz is the most abundant mineral [13]. The common chemical composition of these aggregates is shown in Table 1.1. Concerning the mineralogy, the expanded clay and schist aggregates are essentially made up of quartz, and other silicates with a low percentage of crystallization.

Table 1-1 : Chemical composition of lightweight aggregates of expanded clay and shale aggregates[13].

	SiO_2	Al_2O_3	Fe_2O_3	CaO	MgO	Alcalis	SO_3	S
%	50- 65	16- 25	5- 9	1- 5	1.5- 3.5	1.5- 4.5	0- 1.5	0- 1.5

1.7 Characteristics of lightweight aggregates

1.7.1 Density

The density of lightweight aggregate is a fundamental characteristic that significantly influences the mechanical characteristics of lightweight aggregates and therefore the performance of concrete. Different densities can be defined for aggregates depending on the operating mode used [14].

1.7.1.1 Bulk density

The mass of dry aggregate occupied by unit volume is called bulk density. The original density is calculated according to EN 1097-3. The bulk density of the aggregates is as follows:

$$\rho_v = \frac{M_s}{v} \quad (\text{Eq 1.1})$$

With

M_s :is the mass of the aggregates placed in place without settlement in the container,

V: the volume of the container.

1.7.1.2 Actual density

The actual density of grains is defined as the ratio of an aggregate sample's mass to its grain volume. According to EN 1097-6, the grain volume is defined by the outer shell of the grain, including the pores. Actual densities include the density determined after oven drying, the absolute density mass, and the actual saturated dry surface density. Each concept's definition is provided below. The actual density is determined in a single operation using the EN 1097-6 pycnometer method. To be more representative of the actual state of the aggregates during mixing, we do not remove thin elements less than 0.063 mm from light aggregates.

There is no standard for light aggregates < 4 mm. EN 1097-6 for sands of normal density is usually used, however, ensuring a saturation of 24h. The fine aggregates are dried on the surface using a low current of hot air from a hair dryer.

The density masses (absolute, real and saturated dry surface) are determined according to the formulae in NF 1097-6:

- Actual density determined after drying in the oven: it corresponds to the ratio of the mass of a sample of aggregates dried in the oven to the total volume of the grains including the solid, the closed pores and those accessible to water

$$\rho_{rd} = \frac{M_4}{M_3 - (M_2 - M_1)} \quad (\text{Eq 1.2})$$

- Actual saturated density dry surface: This is the ratio of the mass of a sample of aggregates including the mass of water in the water-accessible pores to the total volume of grains including solid, closed and water-accessible pores.

$$\rho_{ssd} = \frac{M_1}{M_3 - (M_2 - M_1)} \quad (\text{Eq 1.3})$$

- Absolute density: it corresponds to the ratio of the mass of a sample of aggregates dried in an oven to the volume it occupies in the water, that is to say the volume of the solid and that of the closed pores.

$$\rho_a = \frac{M_4}{M_3 - (M_2 - M_4)} \quad (\text{Eq1.4})$$

The intergranular porosity of aggregates is calculated from the bulk and actual density. It is written:

$$\rho_{int} = 1 - \frac{\rho_v}{\rho_{rd}} \quad (\text{Eq 1.5})$$

1.7.2 Water absorption and water-accessible porosity

Knowledge of the density of light aggregates and capacity water absorption are necessary to correctly determine the volume of light aggregates to be added to the mixture. Light aggregates are used in the saturated state to avoid any change in E/C ratio due to the water

absorption of the aggregates during mixing. Absorption kinetics are measured to determine the 'saturation' point [14].

1.7.2.1 Water absorption

The absorption coefficient is the ratio of the increase in mass of a sample of aggregates to its dry mass, due to the penetration of water into the pores accessible to water. Water absorption from aggregates is also determined by the pycnometer method. The measurements comply with EN 1097-6. The coefficients of water absorption at intermediate times are calculated with reference to the 48-hour one according to EN1097-6 [14]:

$$W_a^i = W_a^{48} - \frac{M_2^{48} M_2^i}{M^s} \quad (\text{Eq 1.6})$$

With W_a^{48} the 48h water absorption coefficient identified by the pycnometer method, M_2^{48} and M_2^i the mass of the pycnometer and the container at 48 hours and at the time of the intermediate measurement, M^s the dry mass in the oven of the aggregates. Each point corresponds to the mean value obtained for three measurements on different samples. More than 50% of the water absorbed at 48h is during the first 5 minutes. Water absorption slows down after 24 hours. It will therefore be preferable to immerse the aggregates for 48 hours before mixing in order to avoid water absorption of the aggregates during mixing. This leads to better control of the E/C ratio.

1.7.2.2 Porosity accessible to vacuum water

In order to determine the total water-accessible porosity of the material, it is necessary to first empty the air and water from the pores before filling them. A vacuum saturation device is used to measure the water-accessible porosity of aggregates. The measurement procedure is then similar to the pycnometer method described in EN 1097-6.

The aggregates are dried in the oven at 105°C to a constant mass, that is, when their masses do not vary by more than 0.1% after 1 hour of drying. The sample is cooled to room temperature for at least 12 hours and weighed to determine the dry mass M_1 . A container containing aggregates is inserted into a hermetically sealed glass bell in which a pressure of 90 mbars is applied with a vacuum pump for 15 hours. This operation eliminates the maximum amount of air trapped in the pores of aggregates. Before being introduced into the tank, the distilled water is degassed by agitation in a low-pressure atmosphere of 90 mbars.

The bin in the vacuum bell is then filled with water until the aggregates are immersed about 20 mm high. The aggregates are held in water always under vacuum for 24 hours so that the water fills all the connected pores of the grains. At the end of this stage, the saturated aggregates are finally dried on the surface with wet cloths and weighed to have the mass M_2 . The total porosity of aggregates is the ratio of the volume of voids (equal to the volume of water absorbed) to the actual volume of grains measured by the pycnometer method [14]:

$$\emptyset^v = \frac{V_{vide}}{V_{grain}} = \frac{\frac{M_2 - M_1}{\rho_{eau}}}{\frac{M_1}{\rho_{rd}}} \quad (\text{Eq 1.7})$$

1.7.2.3 Porosity measured by mercury intrusion

The mechanical and thermal properties of the aggregates are related to their mineralogical and chemical composition but also to the microstructure of the grains. In addition to the porosity accessible to water, the knowledge of mercury intrusion porosity and the distribution of pore sizes will allow us to characterize the microstructure differences between the aggregates.

The method involves measuring the amount of mercury that can enter the pores of a solid under increasing pressure. The injection of mercury is pressure-controlled because mercury is a non-wetting fluid, meaning that it does not enter the porosity spontaneously. As the pressure increases, the mercury enters the more and more occluded areas of the porosity, filling increasingly fine pores. At each pressure step, the volume of mercury inserted into the material is measured. This makes it possible to calculate not only the total porosity to mercury but also the distribution of pores whose sizes correspond to the different pressure values. The maximum pressure of our device is 200 MPa corresponding to pore inlet diameters of 6 nm (0.006 μm). Porosity varies between 25% and 60% depending on the type of aggregate [14].

1.7.3 Mechanical properties

The mechanical properties of lightweight aggregates are difficult to accurately assess given the characteristics of each grain (porosity, density, etc.).

1.7.3.1 Conventional strength

The conventional strength of the aggregates in N/cm² is defined by the quotient of the force of necessary to obtain the depression of 20 mm of the piston per section of the cylinder. it characterizes by the pot crushing test, developed by the central laboratory for bridges and roads (LCPC).

1.7.3.2 Bulk crushing

To measure the bulk crushing strength, a sample of aggregates compacted by vibration is compressed using a piston, in a cylinder 100 mm high and 175 to 200 cm² in section. The piston depression rate is 0.2 mm per second and the test is terminated when the piston depression reaches 20 mm.

1.7.3.3 Hydrostatic strength (bursting pressure)

An aggregate is placed in a very deformable plastic enclosure, which is placed in an oil bath of the press. This oil is put under pressure, in stages, until the crushing of the light aggregate in a triple grip, which is manifested by a sudden drop in pressure. The strength of the grain is then characterized by the braking pressure.

1.7.3.4 Tensile strength

Tensile strength by splitting the wire test established it consists of placing a thin steel wire around a light aggregate and exerting an increasing traction, until the grain is cut in two. Grain strength is characterized by the ratio of tensile strength at break to the area of the loop that forms the steel wire around the grain.

Traction and compression tests on expanded clay grains 20 mm in size and tensile and compressive strengths of 2 and 10 MPa respectively were measured.

1.7.4 Elastic properties of lightweight aggregates

Based on an ultrasonic test, we can characterize Young's modulus, Poisson's ratio and shear modulus. In this test, we measure the impulse velocities of longitudinal and transverse waves through an aggregate. Young's modulus, Poisson's ratio and shear modulus were calculated in correlation with these velocities. It is noted that the Young's modulus of the expanded clay aggregates varies between 2000 and 17000 MPa.

1.8 Thermal conductivity

Thermal conductivity λ is the flux per square meter passing through a material one-meter-thick for a temperature difference of one degree between its two faces. This propagation of energy occurs in a solid by agitation of the constituent molecules of the material. The thermal conductivity λ is therefore an intrinsic quantity of material which depends solely on its constituents and its microstructure.

Veronique [15] reported that there is a relationship between porosity and low thermal conductivity, which must be the mode of heat transfer between an immobile solid and a moving fluid.

In the production of lightweight aggregates, a vesicular structure is produced that acts as an excellent insulator. When used in concrete, they reduce the thermal conductivity of the concrete by about a factor of two when the density of the concrete is reduced from 2400 to 1800 kg/m³. Lightweight aggregates can be made of clay with an additional expanding agent added to them such that when they have been fired and cooled, the dry particle relative density is as low as 0.5, and when they are incorporated into concrete, a density of about 800 kg/m³ is produced with a thermal conductivity about one order of magnitude less than normal concrete [4].

1.9 Shrinkage

This is a dimensional reduction of concrete or mortar in the absence of loading, due to the removal of some of the mixing water and the hydration reactions of the cement grains. The seat of shrinkage is located in the cement paste, depending on the circumstances, can develop in a concrete five types of shrinkage: plastic shrinkage, drying shrinkage, endogenous shrinkage, thermal shrinkage and carbonation shrinkage. These shrinkages cause internal stresses that materialize by the appearance of micro and macroscopic cracks on the concrete surface or in its entire mass, these cracks deteriorate the aesthetics and damage the element, such as the acceleration of corrosion of concrete and reinforcements by allowing aggressive agents to penetrate.

1.10 Effective water content and water to cement ratio

The water-binder ratio shall be based on the effective water content of the mix. The effective water content is defined as the total water content (incl. possible surface water of the aggregates) minus the sum of initial water content of the aggregates and the mix water

absorbed by the aggregates at the time of initial setting. Since LWA has a high-water absorption potential, determination of the effective w/c is challenging if the LWA is not in a homogenous water saturated condition before mixing. Also, such a condition influences workability as the LWA may absorb some mix water during the fresh state of the concrete. Hence, there is a need to find the portion of mix water absorption by the LWA. The mix water absorption does not only depend on the degree of saturation, but also the state of moisture, i.e. whether the LWA is in a drying or wetting state. Figure 1.10 shows that the absorption in LWA at a given moisture content varies with the state of moisture distribution within the LWA particles.

Typical for LWA in a drying phase is a dry surface and a concentration of moisture in the core (Figure 1.10). Then, LWA will have a higher absorption of mix water than if the LWA is in a soaking phase, i.e. a high moisture content in the surface area and a relatively dry inner core [16].

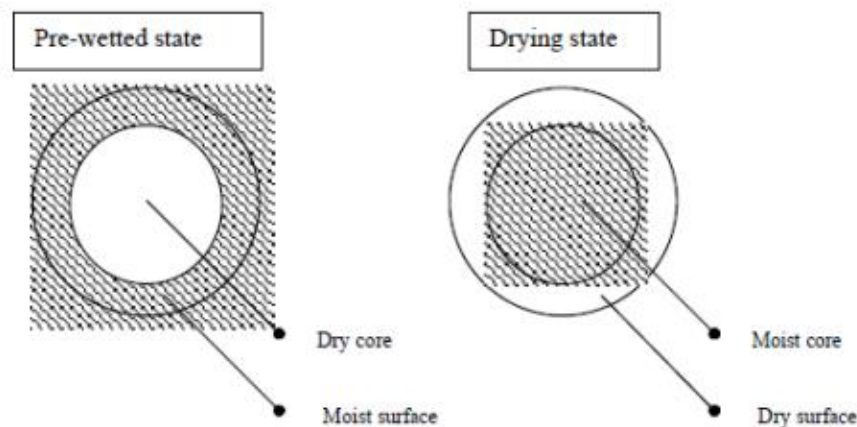

Figure 1.10: Two principal moisture conditions of light weight aggregates [16].

1.11 Difference between lightweight aggregate concrete and normal weight concrete

Differences between lightweight aggregate concrete (LWAC) and normal weight concrete (NWC) concern the mixing stage, hardening stage, ductility and failure modes. In the mixing stage, the porous, water-absorbing lightweight aggregates can affect the workability of the concrete as well as the effective water/binder ratio. In the hardening stage, the relatively low specific heat and high insulating capacity of LWAC will cause a higher hydration temperature. The water initially present in the porous aggregate particles may affect the moisture state in the hardening system to a large extent. Volume changes take place with the changes in the state of water in the pore system in the early stage of hardening. In the

hardened concrete, the differences between LWAC and NWC are mainly due to differences in the strength and elastic modulus of the aggregate, and particularly to differences of the matrix aggregate interfacial zone. These differences determine the degree of heterogeneity of concrete. The properties of the interfacial zone are determined by the surface characteristics of the aggregate, as well as the pore structure and the initial water content of the aggregates.

Depending on the pore structure of the aggregates, some reaction products e.g. calcium hydroxide, will even penetrate into the pores of the aggregates. This is more likely in aggregates with higher absorption and bigger pores. The strength of many lightweight aggregates is about the same as the strength of the hardened paste. The matrix aggregate interfacial zone is of a higher quality than in the case of NWC. The bleeding effect on aggregate surfaces is also reduced due to the reduced response of the LWA to vibration energy during compaction of the concrete. It means that in many LWAC, the interfacial zone is not the weakest link. With comparable modulus of elasticity for the LWA and the mortar, the stress will be more evenly distributed in LWAC than in NWC. Often, the LWA has even lower modulus of elasticity than the mortar phase, causing the mortar to attract more stress. The resulting local transverse tensile stress will act in the mortar, and not in the interface zone. As a matter of fact, in this case, the interface zone will partly be confined by transverse compressive stress. The strength and fracture toughness of LWA are substantially lower than those of normal weight aggregate (NWA) of natural origin, and possibly even the mortar phase. The crack initiation of LWAC takes place at a rather high stress level due to the elastic compatibility of the phases. The strength of LWA can be the strength limit of LWAC [2].

1.12 Expanded clay aggregates

Lightweight expanded clay aggregate (LECA) is made from a special expanding clay that contains no or very little lime. In rotary kilns heated to 1100–1300 °C in rotary kiln., the clay is dried, heated, and burned. LECA is porous ceramic product with a uniform pore structure with almost potato shape or round shape due to the kiln circular movement. The abundant numbers of small, air-filled cavities in LECA give its lightweight, thermal as well as sound isolation characterizes.

Since it is exposed to high temperature, the organic compounds burn, as a result the pellets expand and form a honeycombed structure. Whereas the outside surface of each granule melts and is sintered. The resulting ceramic pellets are lightweight, porous and have a high

crushing resistance. It is environmentally friendly, entirely a natural product incorporating same benefits as tile in brick form.

LECA is usually produced from 0.1 mm up to 25 mm and supplied in various range sizes, which some of the common grades are (0-4) mm, (4-10) mm, (10-25) mm and 0-25 mm which has 510, 330, 250 and 280 kg/m³ average density. Some of the important advantages of LECA are lightness, thermal insulation by low conductivity coefficient, sound proofing by high acoustic resistance, moisture impermeable, incompressible under permanent pressure and gravity loads, non-decomposition against severe condition, fire resistant [17].

1.12.1 Clay aggregate manufacturing process

1.12.1.1 LECA manufacturing techniques

LWA was first manufactured commercially in the UK during the 1950s using clay and shale from the mining and slate industries. Additional types of LWA were developed to meet increasing national demand [18]. There are usually two types of LECA manufacturing techniques: sintering and sintering-expanded. The difference between them is in the process of sintering-expanded, the aggregate expands by a larger volume.

The production of the LECA generally requires seven steps: crushing, mixing, grinding, pelletizing, sintering, cooling and sieving. After heating at 1150 °C in a rotary kiln, the clay expanded to about four to five times its original size and took the shape of pellets. This process was originally employed to produce lightweight cubes in Scandinavia in 1930. Expanded clays are clays which may expand up to 5–6 folds by volume as a result of gas release when they are treated with heat. A hard sintered crust is formed on the outer surface, while quite light and highly durable aggregate with a porous clinker-like structure may be produced inside it with bulk weight range 160–850 kg/m³ and cylinder compressive strength within the range 0.78– 14.4 MPa.

The two main stages manufacturing process for producing LWA from clay are granule formation and sintering (Figure 1.11).

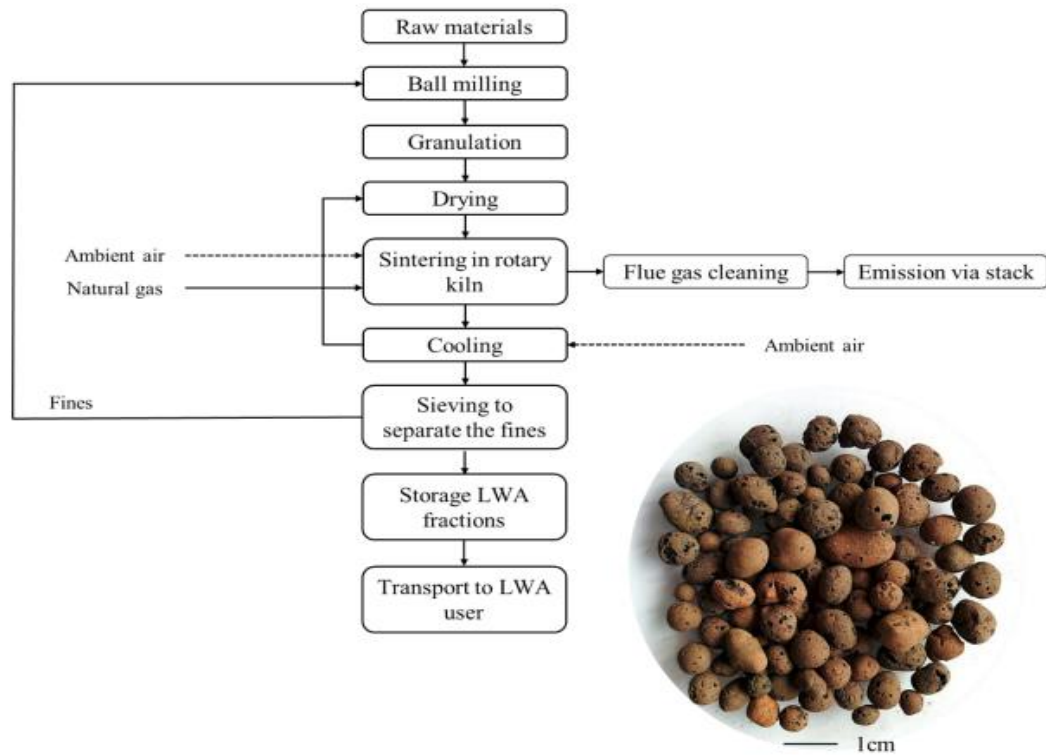

Figure 1.11: Lightweight aggregate manufacturing process flowchart and typical clay end product [18].

1.12.2 Properties of LWA manufactured using clay

Standards for concrete, mortar and grout define LWA as a granular material with a loose bulk density below 1.2 g/cm^3 or a particle density not exceeding 2.0 g/cm^3 .

The pore structure of a clay LWA is a major factor determining particle density, water absorption and strength. Raw material characteristics and production parameters also influence the properties of LWA through the pore structure. The pore structure is therefore an intermediate variable that allows construction of causal pathways, as shown in (Figure 1.12), between the composition, processing and key properties [18].

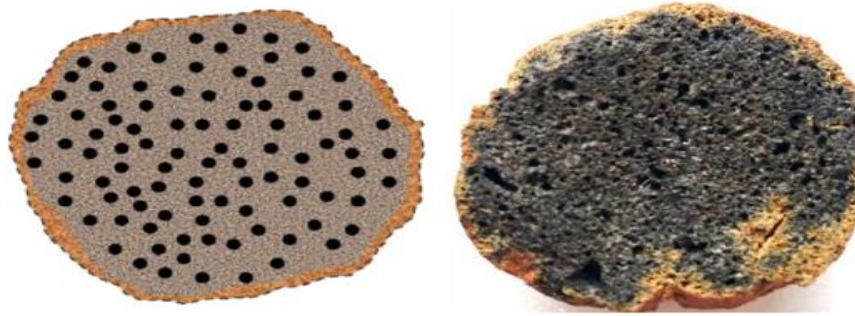

Figure 1.12: Schematic of an ideal pore structure (left) and typical pore structure of clay LWA (right) [18].

1.13 Application domain and advantages

Table 1.2 summarizes the application domains and advantages of LWA.

Table 1-2: Application and domain and advantage of LWA

Application Domain	Advantages
<ul style="list-style-type: none"> • reinforcement rehabilitation. • facade thermal bridge. • technical floor. • filling the vaults. • insulation and drainage of sunken walls. • Slope shape. 	<ul style="list-style-type: none"> • Favourable insulation properties. • high crushing resistance. • Favourable fire resistance. • excellent thermal and sound insulation properties. • Fire resistant. • Reduction of dead load. • Does not break in case of frost.

1.14 The mortar

Mortar is one of the building materials that are used to solidarity elements between them, ensuring the stability of the work, filling the interstices between the blocks of construction.

In any construction, it is essential to bring together the different elements (concrete blocks, bricks, precast concrete elements, etc.) using a cement mortar or other binder which aims to:

- ✓ Join the elements together;
- ✓ Ensure the stability of the structure;
- ✓ Fill the gaps between the building blocks.

The mortar is obtained by mixing a binder (lime or cement), sand, water and possibly additions [19].

1.15 Mortar consistency

1.15.1 Water

The water should be enough to maintain the fluidity of mortar during application, but at the same time it should not be excessive leading to segregation of aggregate from the cementitious material. The quantity of water needed for maintain consistency or fluidity, thinner joints will require greater fluidity; bed joints subject to heavy pressure may require stiffer mortar.

1.15.2 Cement

A cement is a binder, a substance used for construction that sets, hardens, and adheres to other materials to bind them together. Cement is seldom used on its own, but rather to bind sand gravel (aggregate) together. Cement mixed with fine aggregate produces mortar for masonry, or with sand and gravel, produces concrete. Generally, you can use:

- Standardized cements (gray or white);
- Special cements (molten aluminous, prompt);
- Masonry binders;
- Naturel hydraulic lime;
- Slaked lime.

1.15.3 Sand

Sand is a granular solid material made up of small particles resulting from the disintegration of materials of mineral origin (essentially rocks) or organic (shells, coral skeletons). Sand is an essential material for the manufacture of mortar. It forms the mortar structure. The cement, and possibly the lime, binds the grains of sand together.

The sands come from the disintegration of the rocks which constitute the earth's crust, depending on their composition, they are white, yellow, gray, or reddish. The maximum diameter of the grains of sand used for mortar is:

- Extra-fine: up to 0.8 mm (in a sieve), or 1 mm (in a sieve);
- Fine: up to 1.6 mm;
- Medium: up to 3.15 mm;
- Coarse: up to 5 mm [20].

1.15.4 Admixtures

Admixtures are chemicals used in concrete. They modify the properties of the concretes and mortars to which they are added at low proportion (about 5% of the cement weight). Mortar can have different types of admixtures:

- Plasticizers (water reducers);
- Air entrainers;
- Hold modifiers (delays, accelerators);
- Water repellents [20].

1.15.5 The additives

The additions we unusually used in mortars are:

- Fine pozzolanic powders (ashes, silica smoke, etc.);
- Fibers of different natures;
- Dyes (natural or synthetic);
- Polymers [20].

1.16 Classification of mortars

The mortars are classified on the basis of the bulk density and the nature of application:

1.16.1 Bulk density

According to the bulk density of mortar in dry state, there are two types of mortars:

- Heavy mortars.
- Lightweight mortars.

1.16.1.1 Heavy mortars:

The mortars having bulk density of 15 kg/m^3 or more are known as the heavy mortars and they are prepared from heavy quartzes or other sands.

1.16.1.2 Lightweight mortars :

The mortars having bulk density less than 15 kg/m^3 are known as the lightweight mortars and they are prepared from light porous sands from pumice and other fine aggregates, The light mortar is ready to directly receive a glued tile or other coating [21].

1.16.2 Nature of application

According to the nature of application, the mortars are classified into two categories:

1.16.2.1 Bricklaying mortars:

The mortars for bricklaying are intended to be used for brickwork and walls. Depending upon the working conduction.

1.16.2.2 Finishing mortars:

Plastering is a process of rendering mortar into a surface to bond the bricks and also to cover the same inside, outside and ceiling mortar. There are different grades and types of plaster mortars also ways of rendering the same are different. The plaster material should fulfill the following requirements:

- It should adhere to the back pound and should remain adhered during all seasons;
- It should be hard and durable;
- It should possess good workability;
- It should be possible to apply it during all weather conditions;
- It should be cost efficient;
- It should effectively reduce penetration of moisture [22].

1.17 Types of mortar

Mortar is produced by mixing a binding material (cement or lime) with fine aggregate (sand) with water. For construction purpose, different types of mortar are used. Depending upon the materials used for mortar mixture preparation, the mortar could be classified as follows.

1.17.1 Based on binding materials

1.17.1.1 Cement mortar:

Cement mortar is a type of mortar where cement is used as binding material and sand is used as fine aggregate. Highly resistant cement mortars, it has a better compressive strength and his decision is faster. However, it is more subject to removal.

1.17.1.2 Lime mortar:

Lime mortar is a type of mortar where lime (fat lime or hydraulic lime) is used as binding material, the lime mortars are fatty and creamy. They harden more slowly than mortars cements.

1.17.1.3 Refractory mortar:

It is manufactured with melted cement that withstands high temperatures. He is used for the construction of fireplaces and barbecues.

1.17.1.4 Quick mortar:

It is made with quick-setting cement, it is fast and strong for seals.

1.17.1.5 Industrial mortar:

Industrial mortar have been developed in recent years; avoiding the storage and mixing of constituents on construction sites [20].

1.18 Manufacture of mortar

1.18.1 Handcrafted

It must first of all, with the shovel, dry mixing the sand and binder as perfectly as possible and then forming in the middle of a mixing bowl which receives the mixing water. The mass is moistened gradually then kneaded using a mortar crawler.

1.18.2 Mechanical manufacturing

The manufacture of mortars is done using machines called cement mixers with some models, the mixture must be done dry, partly before introduction into the drums mixer where it is suitably wet. Others make the complete mixture themselves: is introduced either directly into the dumper, or into a dumpster, all the elements constituents of the mortar. The operation lasts only a few minutes, it is much more fast and less painful than by hand.

1.19 Use of mortar

1.19.1 Masonry hourdage

The construction made of masonry elements (concrete blocks, cut stone, bricks) (Figure 1.13), requires their assembly with a mortar that shall have mechanical characteristics sufficient to ensure the transmission of loads and sufficient compactness to waterproof [23].



Figure 1.13: Mortar laying [23].

1.19.2 Coatings

This area of application is one of the largest markets for mortars (Figure 1.14). Next to traditional plasters in three layers described in the standard NF P 15 201-1, are now developing monolayers thick coatings as well as insulating coatings.



Figure 1.14: Insulating plasters and facade plasters [23].

1.19.3 Screeds

Screeds serve to ensure the upgrading of the pavement and the regularity of its surface (Figure 1.15). The screed may be the finish: then incorporating it often products specific. They can also provide support for a flooring. Screeds must have sufficient strength to ensure the transmission of loads support, and sometimes resist abrasion or puncture (industrial floors) or adherence floating, the cap can also have a thermal function or acoustic [23].



Figure 1.15: Fluid screeds and cement screed [23].

1.19.4 Seals and wedges

The multiplicity of sealing and wedging problems (Figure 1.16) has less mortar producers manufacturers to develop specific products adapted to the work to be carried out: sealing of roofing elements, street furniture, manholes [23].



Figure 1.16: Sealing's [23].

1.20 Effect of lightweight aggregates on mortar

The incorporation of lightweight materials in mortars can affect the porous structure and the open porosity. The latter depends on communicating empty spaces that allow water to penetrate the mortar, whose permeability depends on the size, geometry and functional groups that coat the pore walls. Since the water absorption and water vapor permeability are important characteristics of renders, it is necessary to evaluate their internal structure and porosity, in order to understand their water-related behavior [8].

1.20.1 Bricks

- Fresh state

The finely ground brick powder has a negative influence on the workability of the mortar as a function of the cement substitution rate, this decrease in workability appears due to the high rate of absorption of brick waste in addition to the irregular shape of its grains.

- Hardened state
 - the strength of mortars based on brick waste decreases with the increase in the rate of substitution in waste. It is also noted that mechanical performance develops in the early days of hydration;
 - The addition of brick waste powder reduces the absorption rate by capillarity.

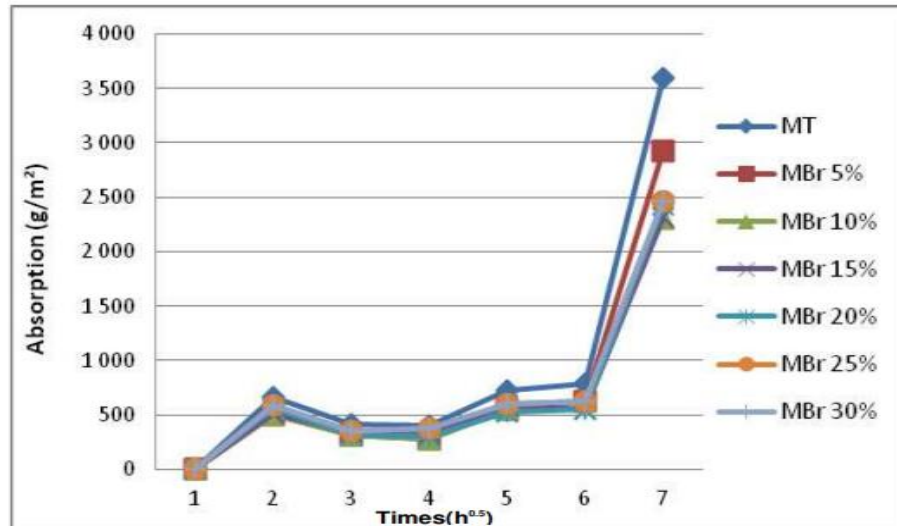

Figure 1.17: Capillarity water absorption for brick waste-based mortars [24].

The results obtained show that brick waste can be technically used as a cement substitute in the manufacture of ordinary mortars.

1.20.2 Diatomite

The formulation of Diatomite (DT) containing mortars showing suitable workability, as defined both by rheometry and by flow table techniques, is strongly restricted in terms of admissible relative amounts of components. The entrained air also increased when DT was added. Diatomite decreased the setting time, the heat release and the time to reach the maximum temperature, Diatomite decreased the water absorption, and apparent porosity of mortars [7].

- Density and porosity

The incorporation of diatomite in the mortar is translated by a gain of the porosity, accompanied by losses on the density. This lightness is due to the high porosity and low density of diatomite [25].

1.20.3 Waste plastic particles

The experimental investigation showed that the addition of rubber particles reduces both the material unit weight and the thermal conductivity. The thermal insulating effect of rubber particles indicates a promising potential for future developments [26].

1.20.4 Scoria

By increasing the percent of scoria in concrete and mortar:

- Compressive strength and tensile strength of mixture has reduced [18].

1.20.5 Perlite

Perlite has been extensively used as a lightweight aggregate material in concrete or mortar, in expanded form perlite offers thermal insulation, fire resistance and other desirable properties when used in Portland cementer gypsum Based plaster.

Expanded perlite:

Vergara and al [27] determine whether the granulometry of lightweight aggregates, in this case expanded perlite (EP), can affect given properties of the mortar. It was found that there is a correlation between the expanded perlite (EP) a fineness module and compressive strength, relationship is linear with a correlation coefficient of 0.94.

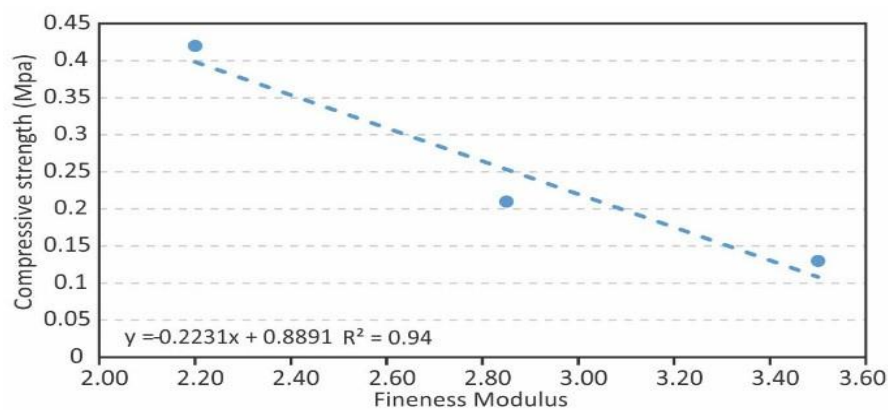

Figure 1.18: Effect of expanded perlite fineness modulus on the compressive strength[27].

The results support this conclusion:

The variation of the EP's granulometry, when this is used as a unique lightweight aggregate in the preparation of mortar, has a noticeable influence on the density of the resulting product, its thermal conductivity, its compressive strength, and its degree of water absorption [27].

1.20.6 Fly ash

Fly ashes do not have the same properties for different size fractions. It can be accepted that the effect of a fly ash on mortar strength is a combined effect of its size fractions. The utilization of fly ash as cement replacement material in concrete or as additive in cement introduces many benefits from economical, technical and environmental points of view.

Eskis_ehir Yolu study combined effects of these different properties on the strength of fly ash incorporated mortars were investigated by using different size fractions separately.

The strength of all-in ash added mortars can be found by a calculation based on the strengths of mortars with size fractions of the same ash by using the amount of the fractions in the all-in ash as weight. However, this method slightly underestimates the strength value of original ash added cements [28].

1.20.7 Pumice

Pumice is essentially an aluminum silicate of igneous origin with a cellular structure formed by a process of explosive volcanism, because the cellular structure, lightweight and insulating properties of pumice has been extensively used as a building construction material.

Lightweight aggregates such as pumice, foamed slag, and expanded clay products have high resistance to fire, and concrete made from them has a low heat conductivity.

Aydin and al [29] find that the Pumice aggregate mortar with cement as a binder has a good high temperature resistance up to 600 °C. This mortar showed only about 4% compressive strength loss and 32% flexural strength loss at 600 °C (cooled in air). However, at the temperature of 900 °C, the mechanical properties of this mixture dropped significantly. The residual compressive strength and flexural strength at this temperature was merely 32% and 20%, respectively.

1.20.8 Waste glass

Glass is a transparent material formed by melting a mixture of materials such as silica, soda ash, and CaCO_3 at high temperature followed by cooling during which solidification occurs without crystallization [10].

One positive way is to use glass waste as a replacement for fine natural aggregate, the effects of adding glass cullet to the mechanical properties of mortar were carried out. The glass aggregate made from recycled post-consumer waste glass (food, medicine, bottles).

Marcin and al [30] we study was to assess the possibility of using a glass sand aggregate made from post-consumer waste glass (food, medicine, and cosmetics packaging, including mostly bottles) in concrete that is difficult to recycle and is stored in large quantities in landfill. The conclusions of this experimental work are:

- A decrease in the slump cone with the addition of recycled glass aggregate was observed, except 5 wt.% of GSA. However, all mixes were within slump cone class (Fig. 1.19).

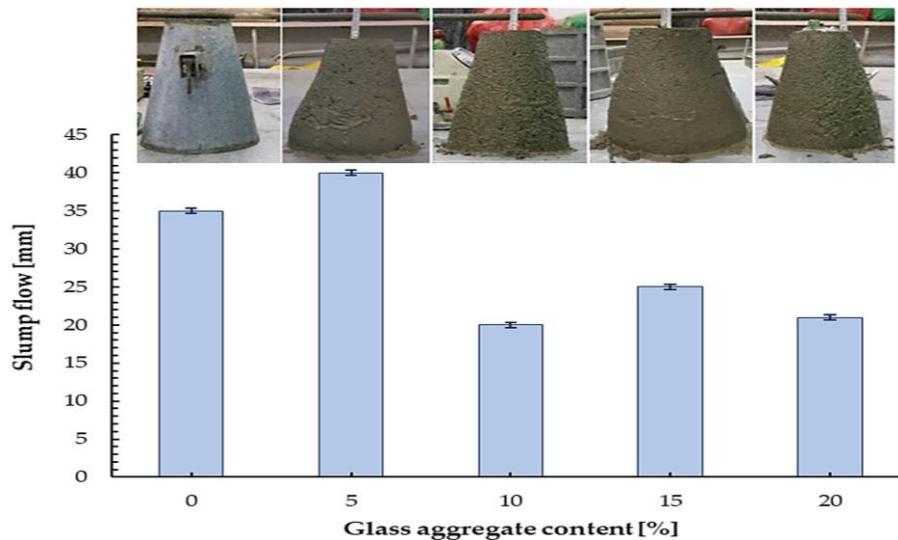

Figure 1.19: Slump cone test results after 150 s [29].

- The air content of mortar with fine glass aggregate was about 2%. The slightly higher air content of concrete containing 20% of glass content was observed, while the obtained differences of air content for mortar with 0% to 15% of glass cullet were practically within the measuring error limit.
- With the increasing of glass sand content, the density of mortar decreased (Fig. 1.20), but this effect is inconsiderable (0.7–3.2% compared to the reference sample). The reduction in hardened density is due to the lower specific gravity of the glass cullet than the granite sand.

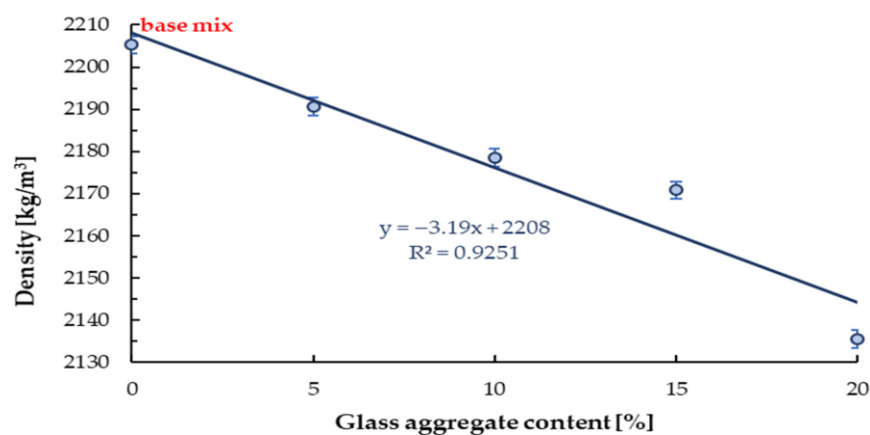

Figure 1.20: The impact of glass cullet ratio on the density of mortar with GSA[29].

- With the addition of 5, 10, 15 to 20 wt.% glass aggregate, the increase in compressive, flexural, and split tensile strength of mortar with GSA compared to the reference mix were ranging about from 11% to 29%, 3% to 14% and 20% to 23%, respectively

(Figures 1.21 & 1.22). The least increase in strength of mortar containing recycled glass aggregate was obtained for flexural strength, while the highest for compressive strength. The increase in mechanical properties was probably achieved thanks to the use of fine glass aggregate particles (0–1.5 mm), which enhance the aggregate-cement matrix bonding strength and the use of green glass aggregate with higher Mohs hardness. Each time, the greatest increase in strength was obtained for green glass with a small particle size up to 20% [29].

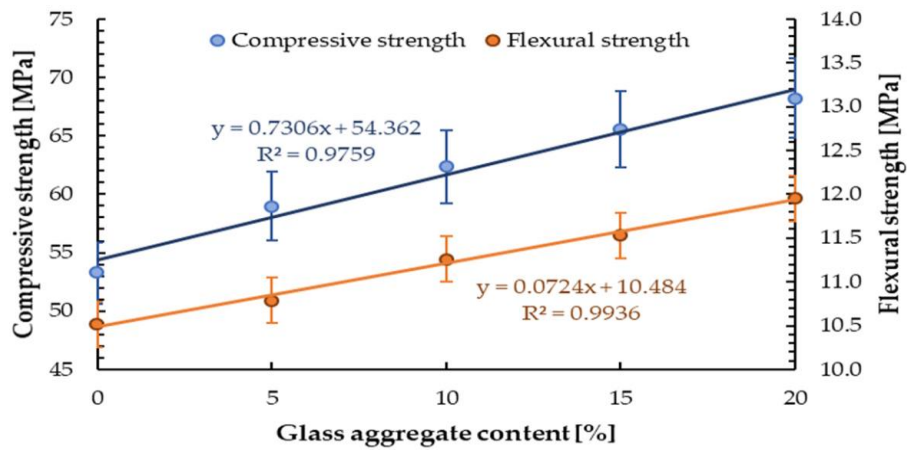

Figure 1.21: Compressive and flexural strength depending on GSA ratio[29].

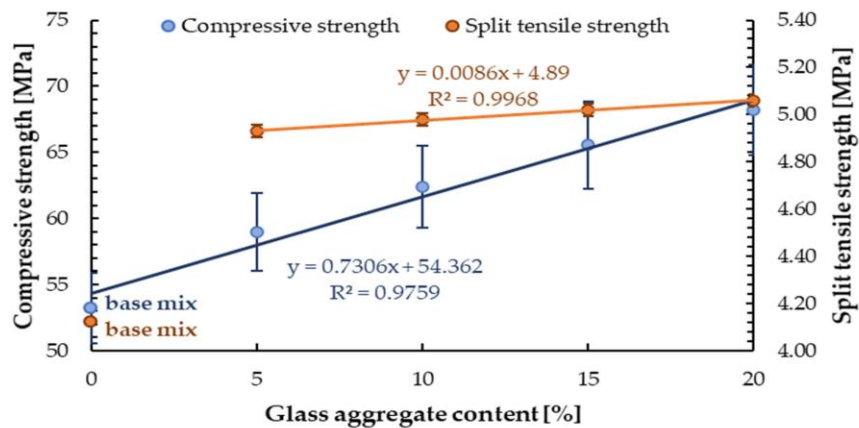

Figure 1.22: Compressive and split tensile strength of samples with GSA depending on GSA content[29].

1.21 Conclusion

According to this study we have noticed the role of expanded clay aggregates and its effects on ordinary and self-compacting mortar with fresh and hardened state. The density is reduced making it suitable to reduce weight of buildings in case of high rise buildings and low quality soil and also for insulation purposes. However, the compressive strength is reduced and the water absorption increased.

2 Chapter 2: Experimentation and test program

2.1 Introduction

In this chapter are reported the main characteristics of the materials used in this work, the program of the tests carried out, the mortar formulation methods, as well as the test methods on fresh mortar and hardened mortar.

2.2 Characteristics of the materials used

2.2.1 Lightweight aggregate

Crushed lightweight aggregates with fraction of 0/3 mm, were obtained from the ALGEXPAN factory. ALGEXPAN-ALGERIE is the only manufacturer of expanded clay aggregates in Algeria, holder of the only clay deposit with expansion properties on the territory. The factory is located in Bouinan (Blida) (Figures 2.1 and 2.2). ALGEXPAN-ALGERIE transforms clay into porous stone by mechanical and thermal treatment without additives.

It is a new material with multiple properties of lightness, mechanical and chemical resistance, insulation, durability, inalterability, fire resistance, non-emission of gas, neutral PH, non-aggressiveness and non-disintegration.

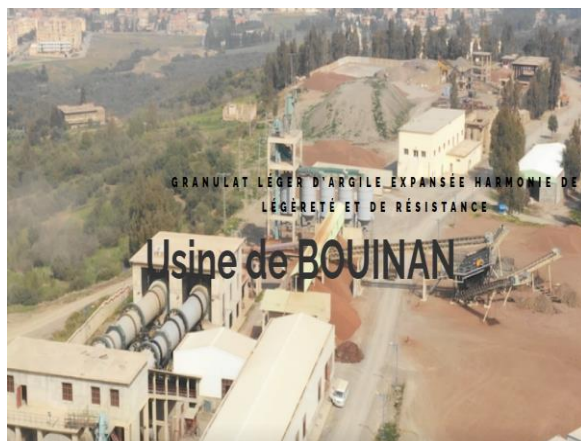

Figure 2.1: The factory



Figure 2.2: Factory logo

Table 2.1 summarizes the fraction of aggregates obtained in this factory.

Table 2-1: The different fractions obtained

NODULAR RANGE	CRUSHED RANGE
<ul style="list-style-type: none"> • Sand NA 0/3 • Gravel NA 3/8 • Gravel NA 8/15 • Gravel NA 15/25 	<ul style="list-style-type: none"> • Sand CA 0/3 • Gravel CA 3/8

The manufacturing process according to the method of ALGEXPAN factory is:

- Extraction of raw material

The extraction of the raw material (clay) is done in the place where abundant quantities have been found (Figure 2.3). Afterwards, using different means of transport to bring these clays to the place of storage and to dry them (Figure 2.4).



Figure 2.3: Raw material



Figure 2.4: The raw material deposit

- **Crushing and mixing**

At this stage, it is used different machines as the crusher, the crusher, to decrease the size of the aggregate of the sample. Afterwards, water is added in order to knead them. Subsequently, these clays are treated with other substances if substance if it is necessary. Then, we lay this mixture in order to obtain a more homogeneous mixture (Figures 2.5 & 2.6).



Figure 2.5: Clay crushed



Figure 2.6: The mixing

● **Drying**

To avoid other imprudent reaction, it is done in the open air. This stage necessarily passes through the phase of hardening of the expanded clay. Indeed, it takes its plastic property which is already lost during mixing. In addition, the amount of water remaining in this material is large enough to ensure their hardness.

● **Burning and expansion**

This manufacturing is carried out in rotary kilns of about 100 meters long (Figure 2.7). The process begins with the clay entering the kiln at one end and travels the entire length, gradually increasing its temperature. At the other end of the kiln, the temperature reaches about 1200°C; at this point, the clay reaches the pasty state (which precedes the fusion) and begins the process of expansion. They get their round shape by rolling inside the oven, which also causes the formation of the which also causes the formation of the compact and resistant outer shell. The production cycle is production cycle is completely controlled and environmentally friendly because the fumes are cleaned with an electro filter.



Figure 2.7: Rotary kilns

- **Cooling**

This phase follows directly after the expansion phase to prevent the material obtained from melting. So, we have total hardening of this material which improves the mechanical property.

- **Screening**

This step after cooling, it consists of separating the different fractions of the aggregates.



Figure 2.8: Screening

- **Sieving and storage**

After cooling the expanded clay comes out of the kiln in sizes between 0-25mm, it is stored in large piles under cover. It is then shifted in the marketed granulometry and stored partly in the open air and partly in covered silos (Figure 2.8).



Figure 2.9: Silos

2.2.2 Cement

The cement used is a Portland cement composed of CEM II/ B 42.5 N. Table 2.2 summarizes the physical and mechanical characteristics of the cement used whereas tables 2.3 and 2.4 summarizes its chemical and mineralogical compositions, respectively.

Table 2-2 : Physical characteristics of Lafarge cement CEMII/B 42.5 N

Characteristics	ρ abs (g/cm ³)
CEMII/B	2.97

Table 2-3: Chemical composition of Lafarge cements CEMII/B 42.5 N[Réfé]

CaO (%)	SiO ₂ (%)	Al ₂ O ₃ (%)	Fe ₂ O ₃ (%)	Na ₂ O ₃ (%)	K ₂ O (%)	SO ₃ (%)	MgO (%)	CaO (%)	PAF (%)	Insoluble
62.78	18.88	4.65	3.2	0.10	0.64	2.41	2.42	0.94	4.60	1.29

Table 2-4 : Mineralogical composition of Lafarge cements CEMII/B 42.5 N[Réfé]

C3S (%)	C2S (%)	C3A (%)	C4AF (%)	CaO (%)
55	21	8	10	01

2.2.3 Mixing water

The mixing water used is drinking water (tap water) supplied to the civil engineering laboratory at the university of Blida.

2.2.4 Admixtures

MEDAFLOW 30 is a super high plasticizer third generation water reducer based on Polycarboxylates d'Ether. The MEDAFLOW 30 makes it possible to obtain very high-quality concretes and mortars. In addition to its main function as a super plasticizer, it allows without modifying the consistency, to reduce strongly the water content of the concrete. The

MEDAFLOW 30 does not show any effect of set delay. Its characteristics are given in table 2.5.

Table 2-5: Characteristics of the admixture

Aspect	Color	Ph	Density	Chlorine content	Dry extract
Liquid	Light brown	6-6.5	1.07±0.01	< 0.1 g/l	30%

2.2.5 Sand

Two types of sand were used:

- Bougezoul sand: of particle size class 0/3 mm
- Expanded clay sand: Particle size class 0/3 mm (crushed) brought from the ALGEXPAN factory, wilaya of Blida.

2.2.5.1 Absolue density

The absolute density is the mass of one body per unit of volume without the voids between the grains. This test is carried out according to the standard (NF EN 1097-3). Table 2.6 summarizes the results.

a. For ordinary sand

The test tubes are filled with a volume $V_1=800$ ml of water;

We take sample of mass 300g aggregates all while eliminating the air bubbles; we note V_2 ;

It is the mass of the material per unit volume including existing voids between the grains;

Results interpretation $\rho = \frac{M}{V_2-V_1}$ (Eq.2.1)

a. For ordinary sand

The test tubes are filled with a volume $V_1=800$ ml of water;

We take sample of mass 300g aggregates all while eliminating the air bubbles; we note V_2 ;

It is the mass of the material per unit volume including existing voids between the grains;

Results interpretation $\rho = \frac{M}{V_2-V_1}$ (Eq.2.1)

b. For lightweight sand

The real density (EN NF 1097 -6):

- Dry the sample of mass 5000g for 2h in Temperature 250°C

The real density:

$$\rho_{app} = \rho_{moy} - \left(\frac{\rho_{moy} * humidité}{100} \right) \quad (\text{Eq.2.2})$$

Table 2-6: Densities and percentage of humidity of sand

Sample	Dry mass	Humidity %	The density
1	4106	21.24	655.11
2	4117	21.77	
3	4117	21.44	
4	4116	21.44	
5	4124	21.47	
		Mean=21.47	

2.2.5.2 Bulk density

It is the mass of the material per unit volume including existing voids between the grains.

Table 2.7 summarizes the results. Figure 2.9 presents the apparatus used.

- **For lightweight sand 0/3 (crushed)**

- Container used capacity v=5l
- Container mass m= 3658g

$$\rho = \frac{M}{V} \quad (\text{Eq.2.3})$$

With:

M: the mass of the sample (g).

V: the volume of the cylindrical container according to the fraction of aggregates.

Table 2-7: Bulk density of samples

Sample	The Mass (g)	Wet density (kg/m ³)
1	4201	840.33
2	4097	819.4
3	4232	846.4
4	4170	834
5	4155	831
		Mean : 834.22



Figure 2.10: Bulk density

Table 2.8 summarizes the characteristics of the sands used.

Table 2-8: Characterization of sands

Type of sand	Boughezoul sand	Lightweight sand
Bulk density (kg/m ³)	1552	834,22
Absoute density (kg/m ³)	2528	1715
Visual sand equivalent ESV (%)	75	101,63
PSE sand equivalent (%)	70	92,34
Finesse module	1,69688	2,89605
Absorption coefficient (%)	0,67	7,93

2.3 Gradings of the sands used

Figures (2.11) and (2.12) present the grading curves of the natural and lightweight sands used, respectively.

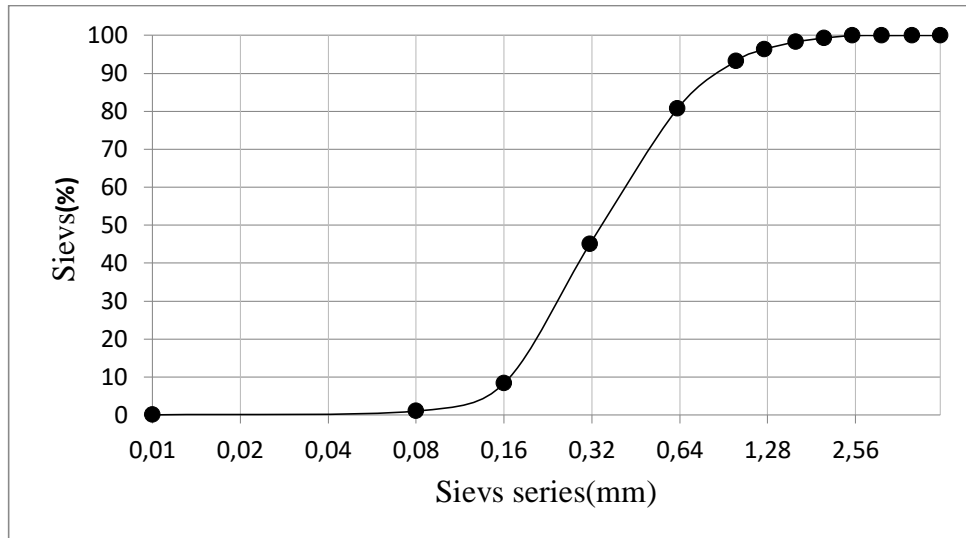

Figure 2.11: Grading curve of Boughezoul sand 0/3

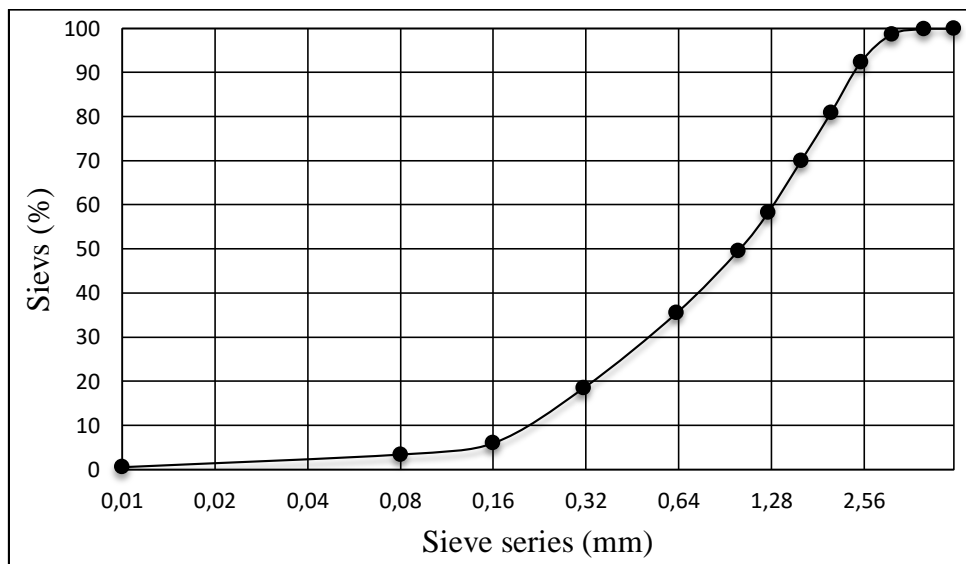

Figure 2.12: Grading curve for expanded clay sand 0/3 (crushed)

2.4 Formulation of mortar

In our study three types of mortar have been formulated which are as follows:

- reference mortar.

- self-compacting mortar with natural sand substitution by lightweight sand (by volume) (0%, 25%, 50% and 75%).
- ordinary mortar with natural sand substitution by lightweight sand (by volume) (0%, 25%, 50% and 75%).

2.5 Composition of self-compacting mortar

Self-compacting mortars have been formulated by the Japanese method, the purpose of this formula is to optimize the quantity of superplasticizer to obtain the best mix of homogeneous self-compacting mortar and sand without segregation and without bleeding.

Table 2.9 summarizes the mortar mixes used.

Table 2-9: Self-compacting mortars mixes

Self compacting mortar								
	E/C	SP %	Absorption %	M cement (g)	M light sand (g)	M Boughazoul sand (g)	Water (g)	
							W1	W2
Reference mortars	0,38	0,8	0,67	1047	/	1883	283	121
25% Lightweight sand	0,38	0,8	2,485	1047	313,59	1535,41	307	132
50% Lightweight sand	0,38	0,8	4,3	1047	615,31	1198,69	331	142
75% Lightweight sand	0,38	0,8	6,115	1047	905,66	874,34	355	152

The mixing procedure is as follows (Figure 2.13):

- dry mixing of cement mixture, sand, light sand hanging 60s to homogenize the mixture,
- adding the first amount of water E1=70% and mixing for 60s,

- mixing for 60s E2=30% water with the superplasticizer,
- mix for 180s after stopping mixing.

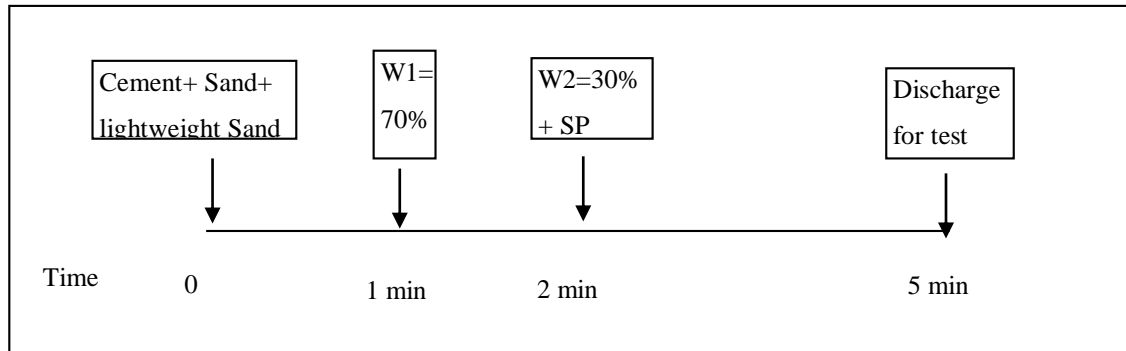

Figure 2.13: Mortar mixing sequence

2.5.1.1 Fresh state of self-compacting mortar

A. Density (EN 1015-6)

The density of a fresh mortar is determined by the quotient of its mass by the volume it occupies or introduced and compacted, in a prescribed manner in a measuring container of a given capacity, it is expressed in (kg / m^3) (Figure 2.14).



Figure 2.14: Density in the fresh state

B. Mini-cone spreading

The spreading test consists of filling the mini-cone placed on a smooth horizontal surface, once the cone is lifted the spreading diameter of the mortar is measured in two perpendicular directions to retain the average. The diameter of the mortar pan must be between 270 and 330 mm is calculated as follows:

$$D = (D+D)/2 \quad (\text{Eq.2.9})$$

C. V-Funnel deformability test

The funnel flow test (or V-funnel test) is used to assess the fluidity and viscosity of SCM (Figure 2.15). A funnel of defined dimensions is filled with mortar to the top. The clapper closure located at its base is then opened, we measure the time (T_v) that the mortar to come out of the funnel until this funnel is completely empty. The flow time of the self-compacting mortar must be between 2 and 10 seconds

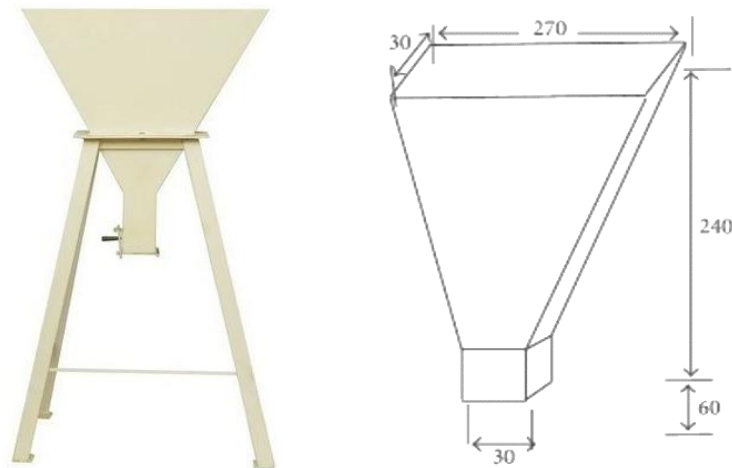

Figure 2.15: Mortar v-funnel test apparatus

D. The air content (BS EN 1015-7)

The test consists of measuring the air content in the mortar; the equipment consists of a container with an approximate volume of 1 liter, the container is filled in four layers, each layer is compacted with ten strokes, after cleaning the container with a damp cloth (Figure 2.16).

The water is introduced through valve A until it comes out of valve B, close both valves and pump the air until a stabilized condition is reached, this is equal to the level determined during the calibration procedure. When the equilibrium is reached the air content is read from the manometer, and read the value of the air content in %.



Figure 2.16: Aerometer

2.5.2 Composition of ordinary mortar

Table 2.10 summarizes the ordinary mortar mixes used.

Table 2-10: Ordinary mortar formulation

Ordinary mortars formulation								
%	E/C	SP	Absorption	M cement (g)	M light sand (g)	M Bougezoul sand (g)	Water (g)	
							W1	W2
Reference mortar	0,5	1.7% 12,50 g	0,67	735,33		2206	258	111
25% LS	0,5	1.7% 12,48 g	2,485	734,33	373,62	1829,38	259	111
50% LS	0,5	5% 36,13 g	4,3	722,67	735,38	1432,62	256	110
75% LS	0,5	5% 36,13 g	6,115	717, 33	1102,06	1063,94	257	110

The mixing procedure is as follows (Figure 2.17):

- dry mixing of cement mixture, sand, light sand hanging 30s to homogenize the mixture,

- adding the first amount of water $E1=70\%$ and mixing for 90s,
- mixing for 150s $E2=30\%$ water with the superplasticizer,
- mixing for 300s after stopping mixing.

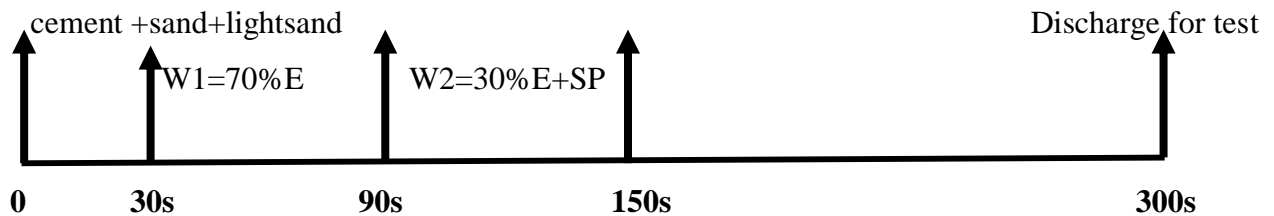

Figure 2.17: Mortar mixing sequence

2.5.2.1 Fresh state of ordinary mortar:

a. Spread test

This test makes it possible to determine the consistency of the fresh mortar by measuring its spread on a table subjected to shocks. The procedure of the test is as follows (Figure 2.18):

- Fill the cone in 2 layers each layer pricked with 20 strokes by means of the compaction rod.
- Trim the last layer.
- Raise the mold and apply 15 shocks in 15 seconds.
- Measures the diameter of the cake thus obtained in 2 directions.
- The spread in % is given by the formula: $E\% = 100 * (D_r - D_i) / D_r$ (Eq.2.10)

With: D_r : final diameter; D_i : initial diameter

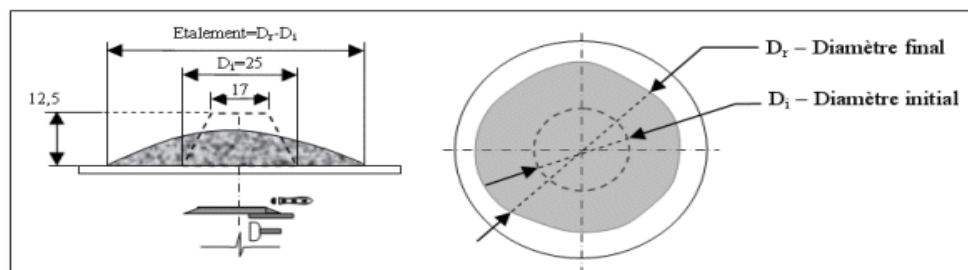

Figure 2.18: Spread test

b. LCPC workability meter

The principle of the test consists, after having removed the mobile wall, in measuring the time taken by the mortar under vibrations to reach a mark engraved on the interior face of the mold. The procedure of the test is as follows (Figure 2.19):

- The mortar is introduced into the largest part bounded by the partition and placed in 4 layers. Each layer stitched 6 times using the stitching rod.
- Trim the last layer.
- The partition is removed, causing the vibrator to start and a time to start at the same time as the partition is removed.

Under the effect of the vibration the mortar flows.

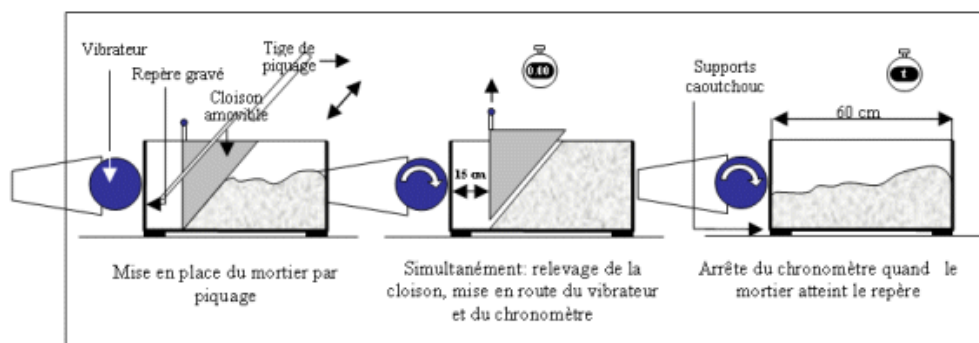

Figure 2.19: Principle of operation of the workability meter

2.6 Hardened state tests of mortars

2.6.1 Preparation and curing of the specimens

All measured specimens were standard shape (40x40x160) mm (Figure 2.20). The studied age was 28 days. The specimens were cured in lime water for 28 days. At ages of 28 days, the specimens were then placed in an oven set at 75 °C for 72 h. The dry weight was determined, and the absorption was calculated based on the dry weight.



Figure 2.20: Prismatic specimens mould (40x40x160) mm

2.6.2 Tensile strength by bending

The flexural strength is a stress at failure in bending. It is equal or slightly larger than the failure stress in tension. Concrete as we know is relatively strong in compression weak in tension. The tensile stresses are likely to develop in concrete due to drying shrinkage rusting of steel reinforcement temperature gradient and many other reasons.

For flexural test beams of (40×40×160) mm size was adopted. The load was applied without shock and was increased until the specimen failed, and the maximum load applied which is on the meter to the prism during the test was recorded (Figure 2.21). The appearances of the fractured faces of concrete failure were noted. Three-point load method was used to measure the flexural strength. The flexural strength of the prisms was calculated as per given equation

Modulus of rupture,
$$R_f = \frac{1,5 F_f}{b^3} \times I \quad (\text{Eq.2.11})$$

Where:

R_f: is the strength in flexion, in Newton per square millimeter or in MPa.

b: is the side of the square section of the prism, in millimeters.

F_f: is the charge applied in the middle of the prism at the rupture, in Newton.

l: is the distance between the supports, in millimeters

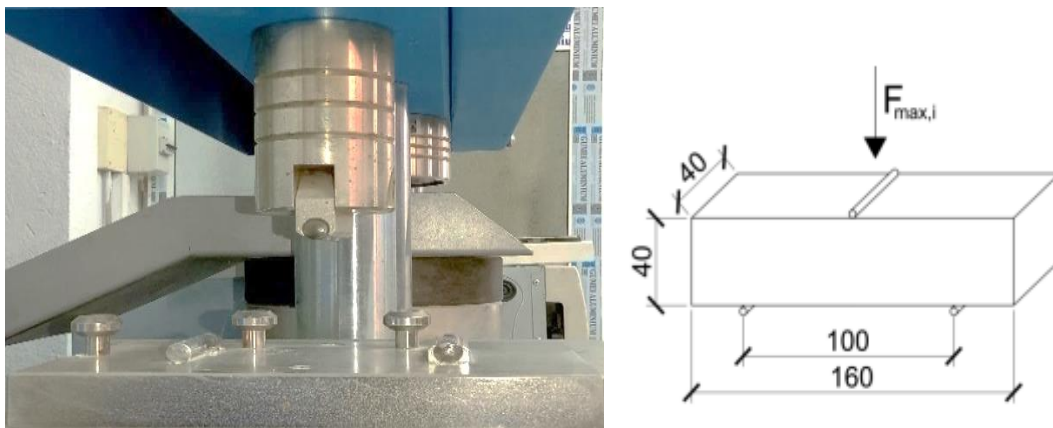

Figure 2.21: Tensile strength by bending test

2.6.3 Compressive strength test (NF EN 12390-3)

The compressive strength of any material is defined as the resistance to failure under the action of compressive forces. Compressive strength is calculated by dividing the failure load with the area of application of load, after 28 days of curing.

Compressive strength is defined as resistance of concrete to axial loading. Cubes are put in the machine and after tighten its wheel start button is pressed as pressure is begin to apply (Figure 2.22). Reading of meter is note down when cracks are there on cubes. Compressive strength is calculated by following formula:

$$\text{Compressive Strength} = P/A \quad (\text{Eq.2.12})$$

Where: P = load; A = area of cube

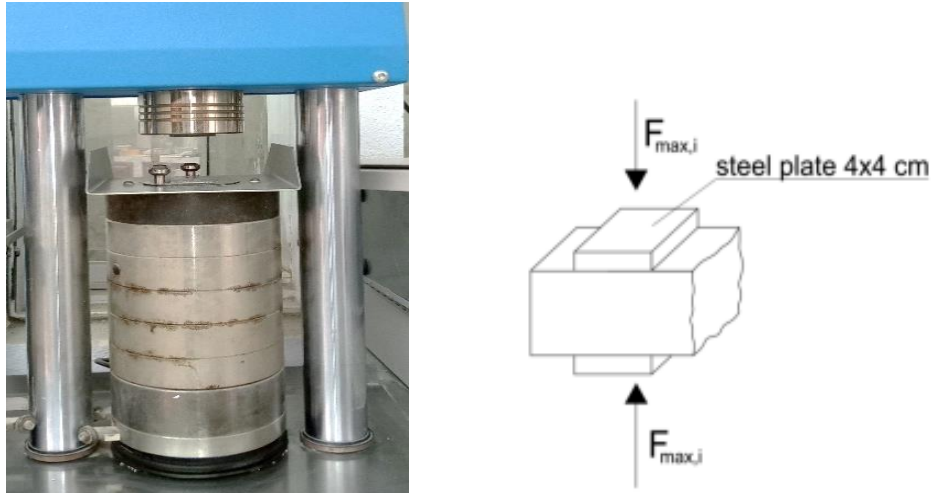

Figure 2.22: Compressive strength test

2.6.4 Thermal conductivity

Thermal conductivity (often denoted by λ) refers to the intrinsic ability of a material to transfer or conduct heat. It is one of the three methods of heat transfer, the other two being convection and radiation. Heat transfer processes can be quantified in terms of appropriate rate equations. The rate equation in this heat transfer mode is based on Fourier's law of heat conduction. It is also defined as the amount of heat per unit time per unit area that can be conducted through a plate of unit thickness of a given material, the faces of the plate differing by one unit of temperature (Figure 2.23).

Thermal conductivity occurs through molecular agitation and contact, and does not result in the bulk movement of the solid itself. Heat moves along a temperature gradient, from an area of high temperature and high molecular energy to an area with a lower temperature and lower molecular energy. This transfer will continue until thermal equilibrium is reached. The rate at which heat is transferred is dependent upon the magnitude of the temperature gradient, and the specific thermal characteristics of the material.

Thermal conductivity is quantified using the International Systems of Unit (SI unit) of $W/m \cdot K$ (Watts per meter per degree Kelvin), and is the reciprocal of thermal resistivity, which measures an objects ability to resist heat transfer. Thermal conductivity equation can be calculated using the following:

$$\lambda = Q \cdot L / A(T_2 - T_1) \quad (\text{Eq 2.13})$$

Where:

Q = heat flow (W)

L = length or thickness of the material (m)

A = surface area of material (m^2)

$T_2 - T_1$ = temperature gradient (K)



Figure 2.23: Thermal conductivity test

2.6.5 Drying shrinkage (ASTM C596-09)

Drying shrinkage is strain associated with the loss of moisture from the mortar or concrete by evaporation of water or hydration of cement. For drying shrinkage test, the size of specimens was (40x40x160) mm as shown in Figure (2.24). The test was conducted in accordance to ASTM C596-09. After demoulding, the mortar specimens were prepared for the installation of demec discs for shrinkage measurement. The demec disc was glued to both sides at a distance of 30 mm from the centre. After that, demec gauge was used to measure initial readings. Shrinkage readings were recorded by using mechanical extensometer. The drying shrinkage strain of each type of mortar was calculated. The percentage of shrinkage was calculated using (Eq 2.14)

$$\text{Percentage of shrinkage} = \frac{L_0 - L}{L_0} \times 100 \quad (\text{Eq 2.14})$$

where, L_0 is original length (length of standard bar) (mm) and L is length as measured during or after cure excluding studs (mm).



Figure 2.24: Extensometer and specimens with demec gauges

2.6.6 Capillary absorption (ASTM C1585-11)

The capillary absorption test consists of measuring the water absorption rate of the concrete and mortar specimens ($40 \times 40 \times 160$) mm without hydraulic pressure, but with capillary suction of the specimens (Figure 2.25). Capillary absorption is carried out according to the ASTM C1585-11 standard on test specimens.

The specimens are dried using an oven until constant mass. Then the side faces are covered with resin, the lower face is brought into contact with water to ensure unidirectional water flow, then the specimens are immersed in a container of water at a height of 5 mm during the test. Then, the measurements of the weight of the specimen during the test are carried out as follows: the specimens are removed from the container, wiped with a sponge, weighed and then returned to the container. The measurements are carried out according to the ASTM C1585-11 standard. Finally, the capillary absorption coefficient is defined by the following equation:

$$I = \frac{mt}{a \times d} \quad (\text{Eq 2.15})$$

with:

I: Capillary absorption coefficient (mm),

mt: the difference in mass of the specimen (g),

a: specimen section (mm^2),

d: water density (g/mm^3).



Figure 2.25: Specimens with resin

2.7 Summary of the tests carried out

The following chart (Figure 2.25) summarizes our experimental program:

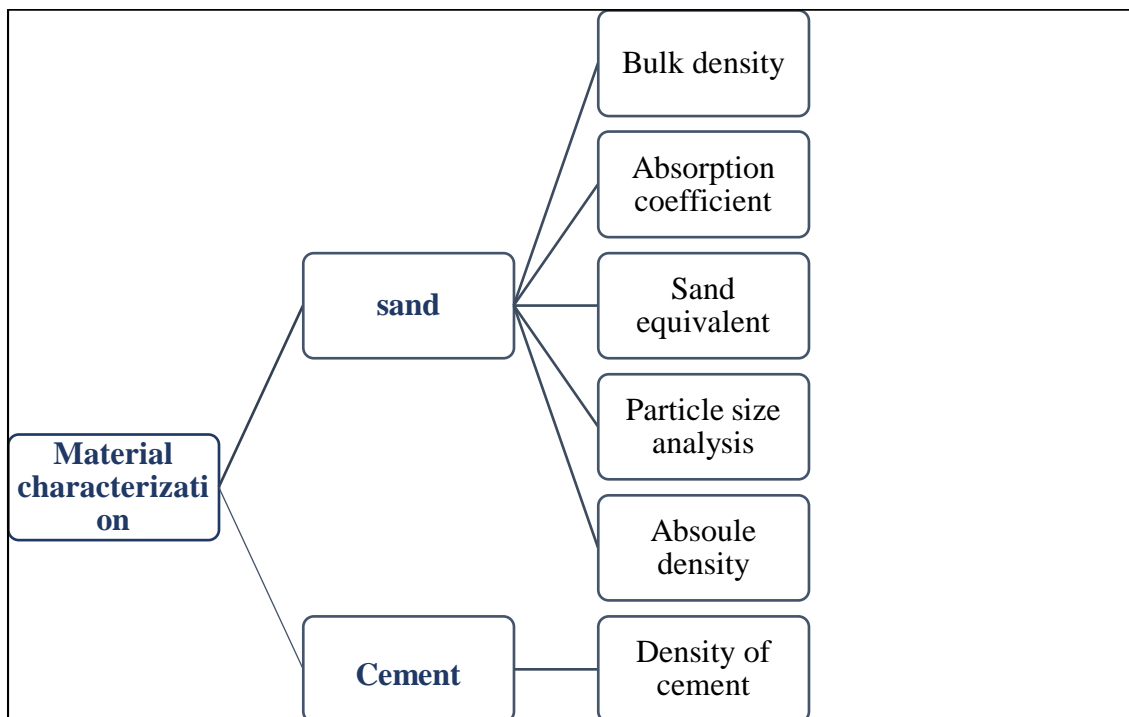

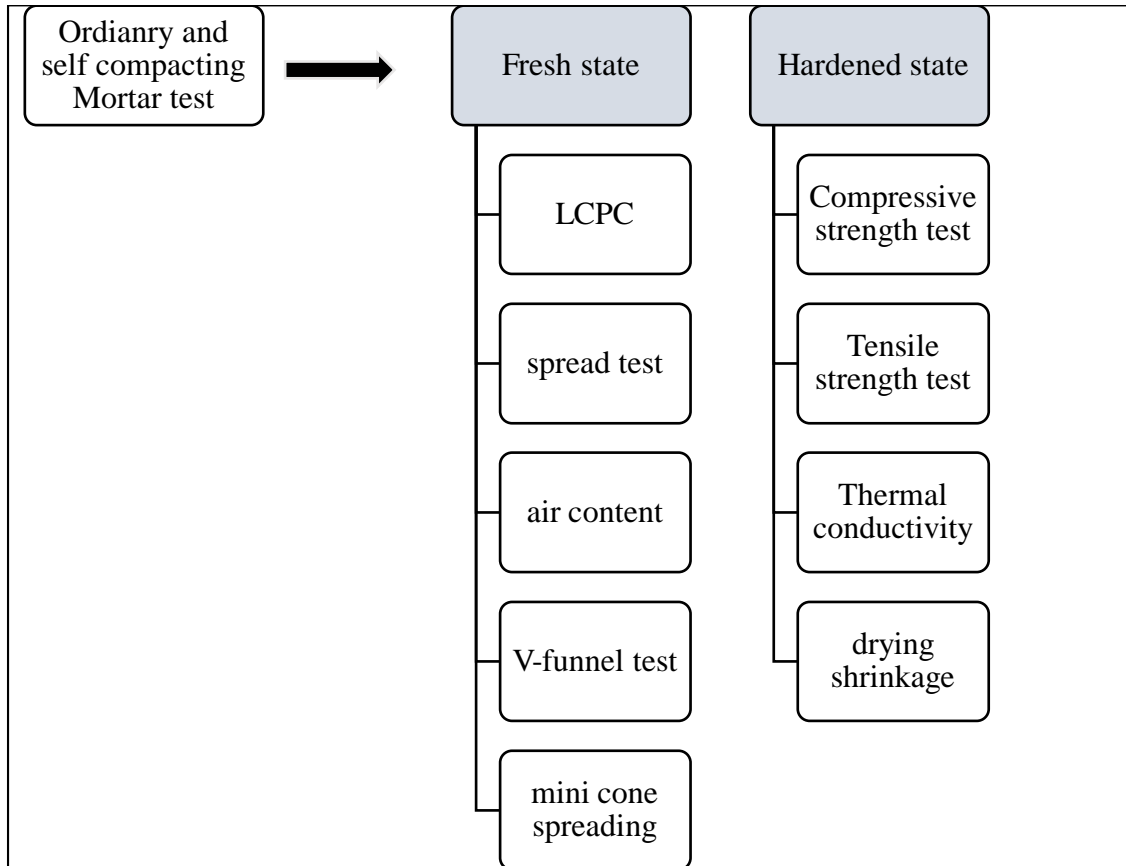

Figure 2.25: Summary of the tests carried out

3 Chapter 3 : RESULTS AND DISCUSSIONS

3.1 Introduction

This chapter is devoted to the analysis of the results obtained within the framework of our experimental tests of self-compacting mortars (SCM) and ordinary mortar (OM) in the fresh state and hardened state, and to the study of the effect of the replacement of nature sand by the crushed lightweight aggregate on SCM and OM in fresh and hardened state. The results for hardened state they are at the age of 28 days.

3.2 Mini cone test

The results are presented in figure (3.1) for self-compacting mortar and in figure (3.2) for ordinary mortar.

The results show that the different compositions of self-compacting and ordinary mortar the substitution of crushed lightweight expanded clay aggregates in composition of mortar has slightly reduced workability. This decrease is due to the nature and fineness modulus of expanded clay sand used. The higher porosity and higher water absorption of lightweight aggregates will reduce the quantity of water available for the workability. The decrease is higher for mixes with 50% and more of substitution rate for both ordinary and self-compacting mortar. It should be noted that the workability is still good for making good concrete for 75% rate of substitution.

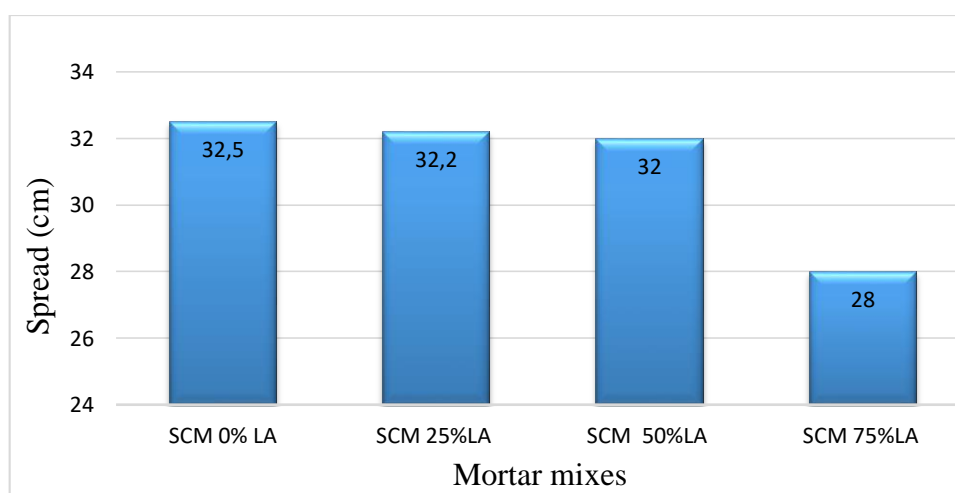

Figure 3.1: Spread of self compacting mortar (SCM)

3.3 Spread test

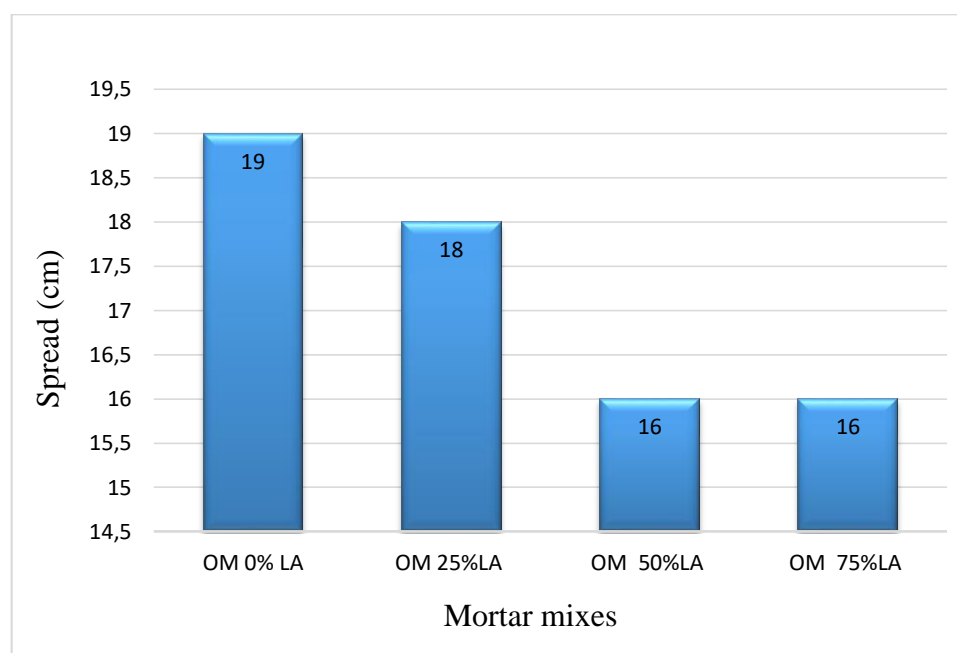

Figure 3.2 : Spread of ordinary mortar (OM)

3.4 Density

The density results for self-compacting mortar are shown in table (3.1) and figure (3.3), whereas the density results for ordinary mortar are shown in table (3.2) and figure (3.4).

As expected, it can be clearly seen that the value of the density decreases when using expanded the clay aggregates in SCM, and this is due the lightness of these aggregates and their low density. The decrease in the density is 5%, 12% et 16% for rates of substitutions of natural sand by lightweight aggregates of respectively 25%, 50% and 75%.

The same tendency is observed for the density of ordinary mortar as the value of the density also decreases when using expanded clay aggregates in OM, and this is due the lightness of these aggregates and its low density. However, the decrease is more important (16%, 41% and 42%°).

Arvialogan [29] reported bulk densities of LECA 40% and LECA 60% varying from 1400-2000 kg/m³.

Table 3-1: Results of density of SCM

Mortar mixes	Density	Relative density to reference mortar (%)
SCM 0% LA	2.08	100
SCM 25% LA	1.98	95.2
SCM 50% LA	1.84	88.5
SCM 75% LA	1.75	84.1

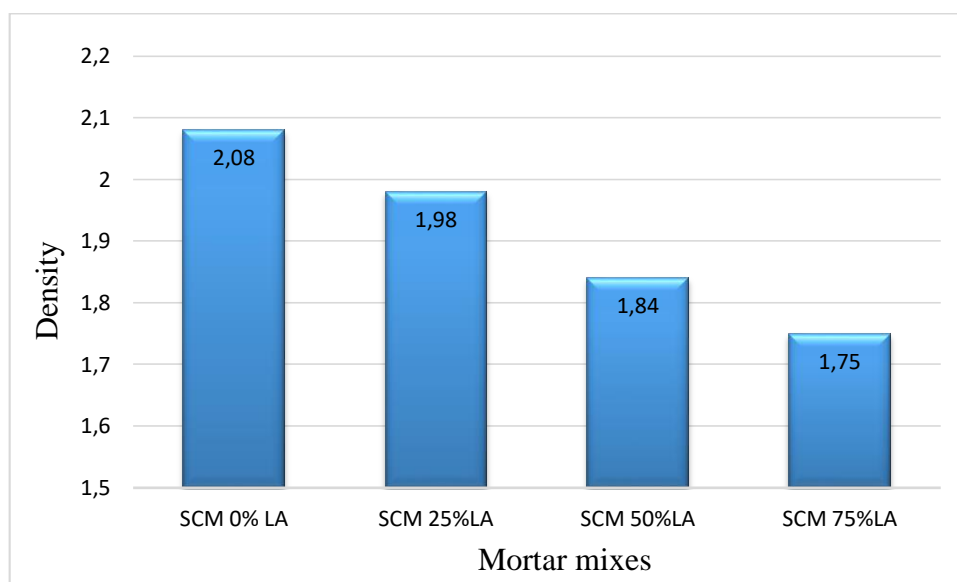

Figure 3.3 : Density of mortar mixes

Table 3-2: Results of density of ordinary mortar

Mortar mixes	Density	Relative density to reference mortar (%)
OM 0% LA	2.96	100
OM 25% LA	1.89	63.85
OM 50% LA	1.73	58.45
OM 75% LA	1.72	58.10

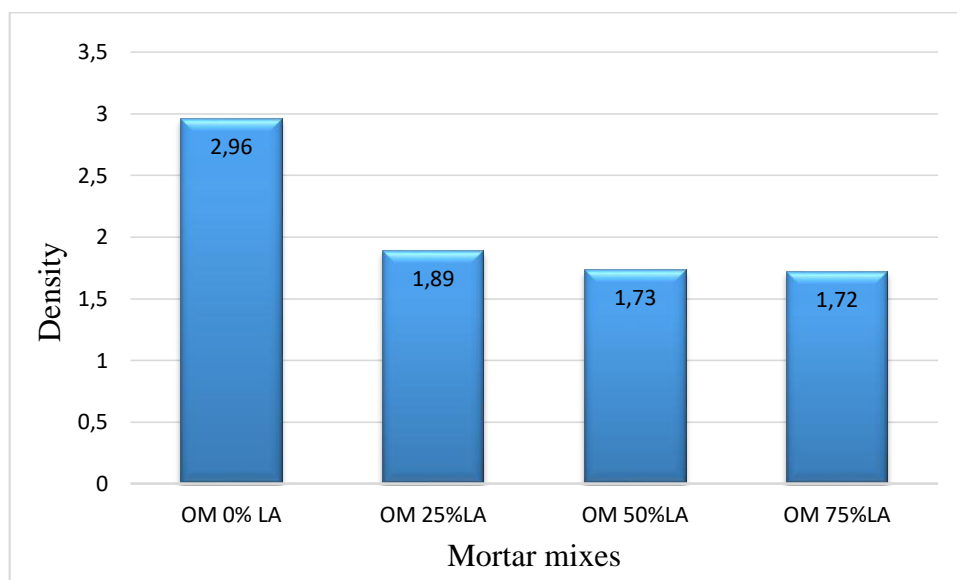

Figure 3.4: Density of mortar mixes

3.5 Air content

The results of air content for self-compacting mortar are shown in table (3.3) and figure (3.5), whereas the results of air content for ordinary mortar are shown in table (3.4) and figure (3.6). It can be concluded that there is a large increase of air content with the increase in the rate of substitution of natural sand by crushed expanded clay. The air content was doubled with 75% rate of substitution (3.5% for reference mortar and 7% for 75% mix). The porous nature of lightweight aggregates might entrap air within the cavities.

A similar tendency of a decrease of air content with the decrease of rate of substitution level is also observed for ordinary mortar. The increase was form 2.7% air content for reference mix to 6% air content for 75% lightweight aggregates mix.

Table 3-3: Results of air content of self-compacting mortar

Mortar mixes	Air content (%)
SCM 0% LA	3.5
SCM 25% LA	4.4
SCM 50% LA	6
SCM 75% LA	7

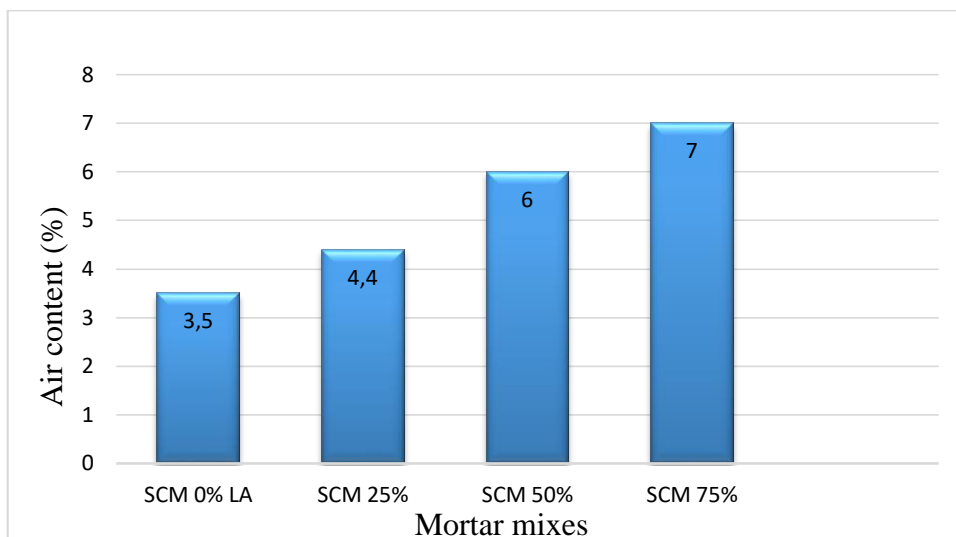

Figure 3.5: Air content of SCM

Table 3-4 : Results of air content for ordinary mortar

Mortar mixes	Air content (%)
OM 0% LA	2.7
OM 25% LA	3
OM 50% LA	5.5
OM 75% LA	6

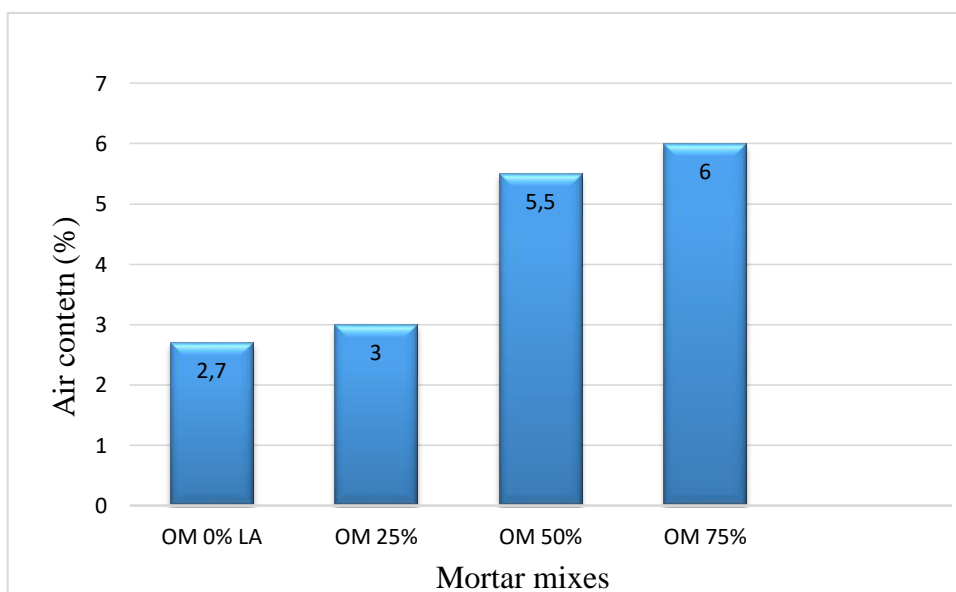

Figure 3.6: Air content of OM

3.6 Drying shrinkage

The drying shrinkage results for self-compacting mortar are shown in figure 3.7. It can be observed that the drying shrinkage of lightweight mortar is more important than that of mortar based on normal aggregate. The shrinkage is related the strength and elasticity of the aggregates and hence the higher shrinkage of lightweight mortar as they resist less to the deformation compared to natural aggregates.

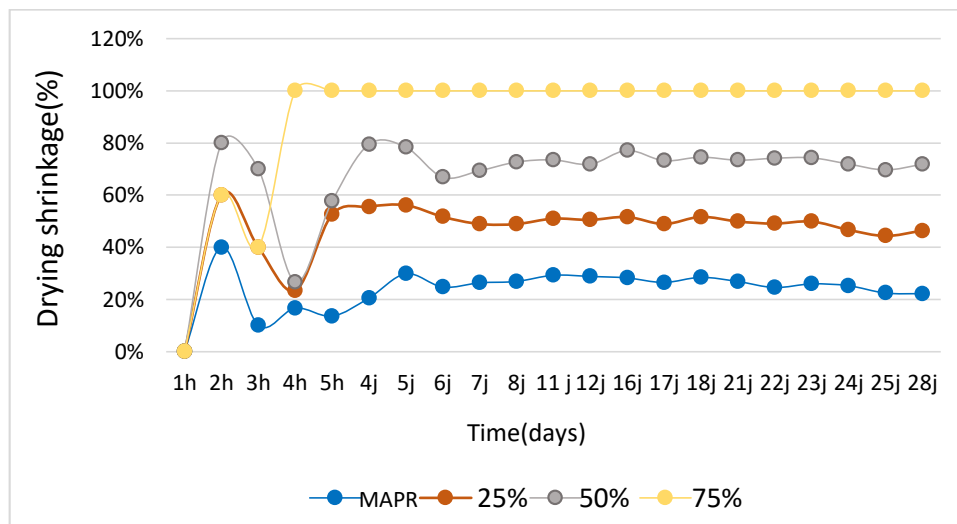

Figure 3.7: Drying shrinkage of SCM.

3.7 Compressive and flexural strength

- Self-Compacting mortar

The results for compressive strength of self-compacting mortar are shown in table (3.5) and figure (3.8), whereas the results for flexural strength are shown in table (3.6) and figure (3.9).

Table 3-5: Results of compressive strength of SCM

Mixes	Compressive strength (MPa)	Relative strength to reference mix (%)
SCM 0% LA	61.4	100
SCM 25% LA	61.1	99.5
SCM 50% LA	58	94.46
SCM 75% LA	53.55	87.21

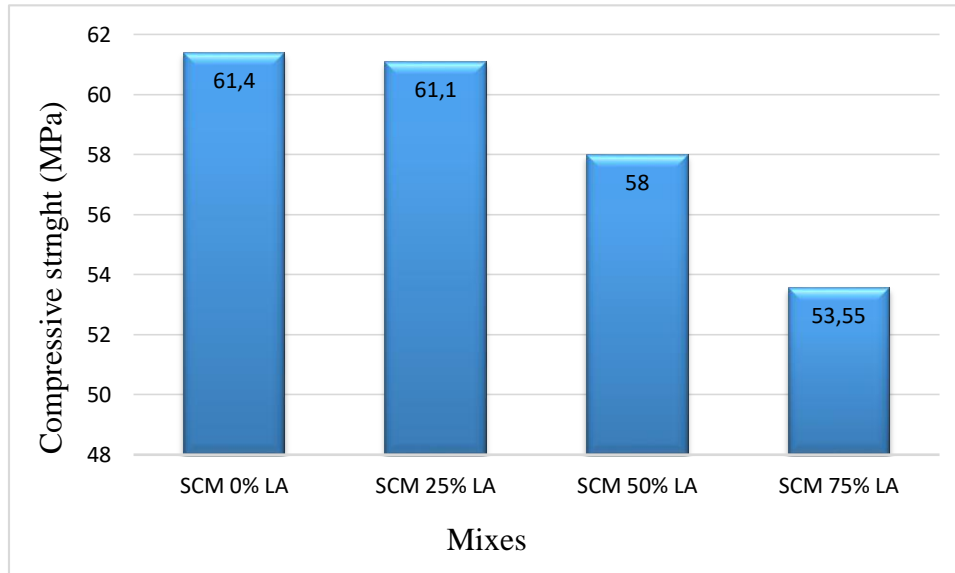

Figure 3.8: Compressive strength of self-compacting mortar

Table 3-6: Results of flexural strength of self-compacting mortar

Mixes	Flexrual strength (MPa)	Relative flexural strength to reference mix (%)
SCM 0% LA	6,35	100
SCM 25% LA	6,25	98.42
SCM 50% LA	5,95	93.80
SCM 75% LA	5,65	88.98

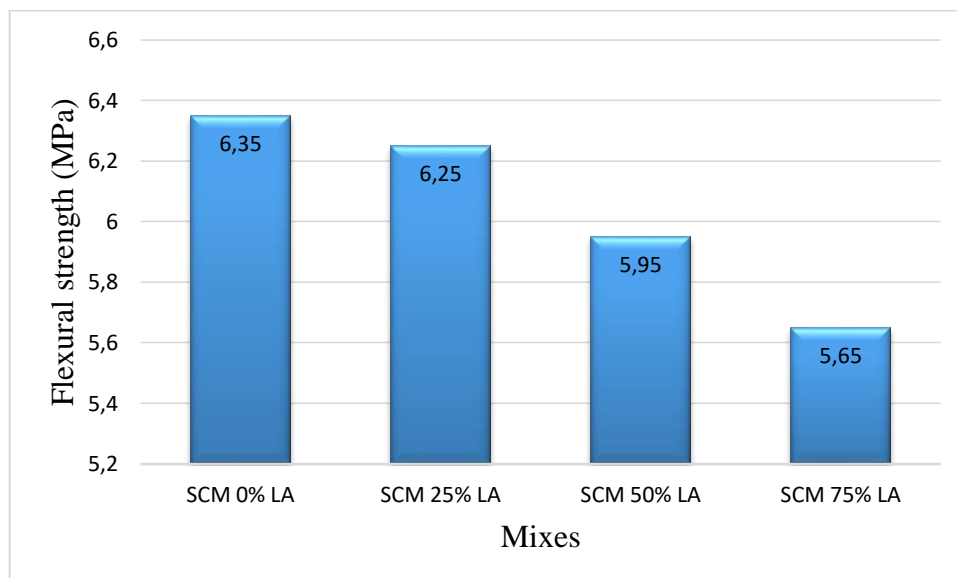

Figure 3.9: Flexural strength of SCM

- **Ordinary mortar**

The compressive strength results of ordinary mortar are shown in table (3.7) and figure (3.10). The flexural strength results are shown in table (3.8) and figure (3. 11).

Table 3-7: Results of compressive strength of ordinary mortar

Specimens	Compressive strength (MPa)	Relative compressive strength to reference mix
OM 0% LA	43,5	100
OM 25% LA	42,75	98.28
OM 50% LA	40,75	93.68
OM 75% LA	39,85	91.61

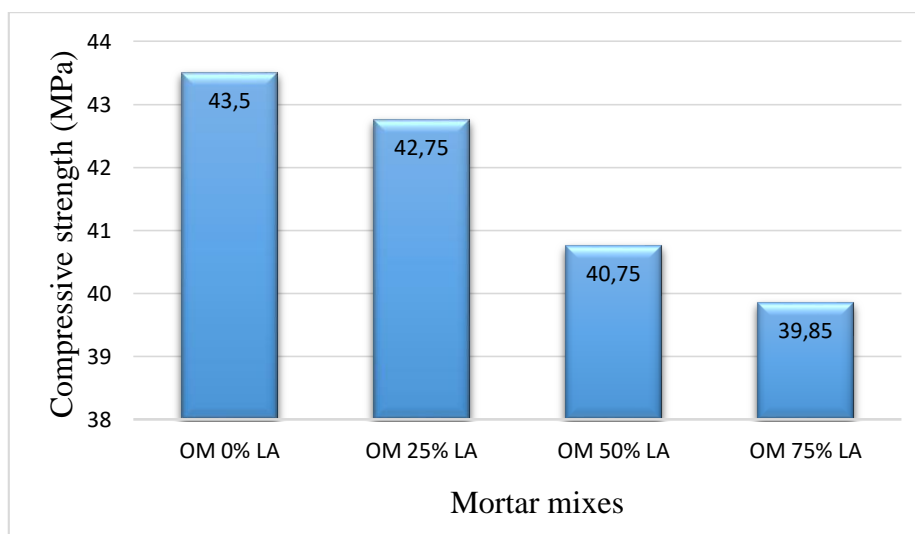

Figure 3.10: Compressive strength of ordinary mortar mixes.

Table 3-8: flexural strength of ordinary mortar mixes

Mixes	Flexrual strength (MPa)	Relative flexural strength to reference mix (%)
OM 0% LA	7,25	100
OM 25% LA	5,95	82.07
OM 50% LA	4,65	64.14
OM 75% LA	4,5	62.07

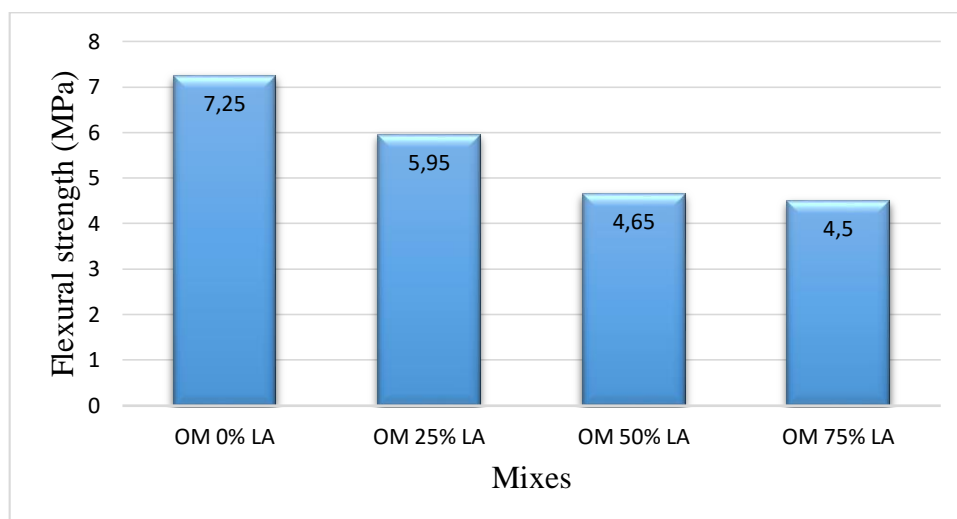

Figure 3.11: Flexrual strength of ordinary mortar mixes.

From the previous tables and figures, we can conclude that there is a decrease in both flexural and compressive strength for ordinary and self-compacting mortar with lightweight fine aggregates as substitution to natural sand compared to the reference mortar.

The decrease in compressive strength was negligible for both ordinary and SCM mixes for 25% and 50% rate of natural sand substitution by lightweight sand (less than 5%). However, the decrease for 75% substitution rate was around 11% to 13%.

The decrease in flexural strength was comparable for SCM mixes but much higher for ordinary mortar mixes where the decrease was 12%, 31% and 38% for 25%, 50% and 75% substitution rate.

The decrease in strength could be related to the lower strength of the lightweight sand, its higher porosity and the higher air content of the mixes.

Comparable results have been found by other researchers. Arvialogan[30] reported compressive strength are 28,56 N/mm², 26,40 N/mm² and strength reduction of 17,36% and 23,69%.

Ramya et al. [31] also found that compressive strength reduces suddenly to 15.259 N/mm² and 21.037 N/mm².

Akçaozoglu and al. [32] reported that the compressive strength mixture produced by naturel aggregates was 58,5 MPa and compressive strength of LECA were 31,1 and 28,8 MPa.

3.8 Thermal conductivity

Thermal conductivity is an important measurement to determine the thermal insulation properties of a material.

The results for thermal conductivity of self-compacting mortar are shown in table (3.9) and figure (3.12). The thermal conductivity results of the ordinary mortar are shown in table (3.10) and figure (3.13).

Table 3-9: Results of thermal conductivity of self-compacting mixes

Mixes	Conductivity (w/m.K)	Relative conductivity to reference mix (%)
SCM 0% LA	0,8417	100
SCM 25% LA	0,7144	84.88
SCM 50% LA	0,6222	73.92
SCM 75% LA	0,4457	52.95

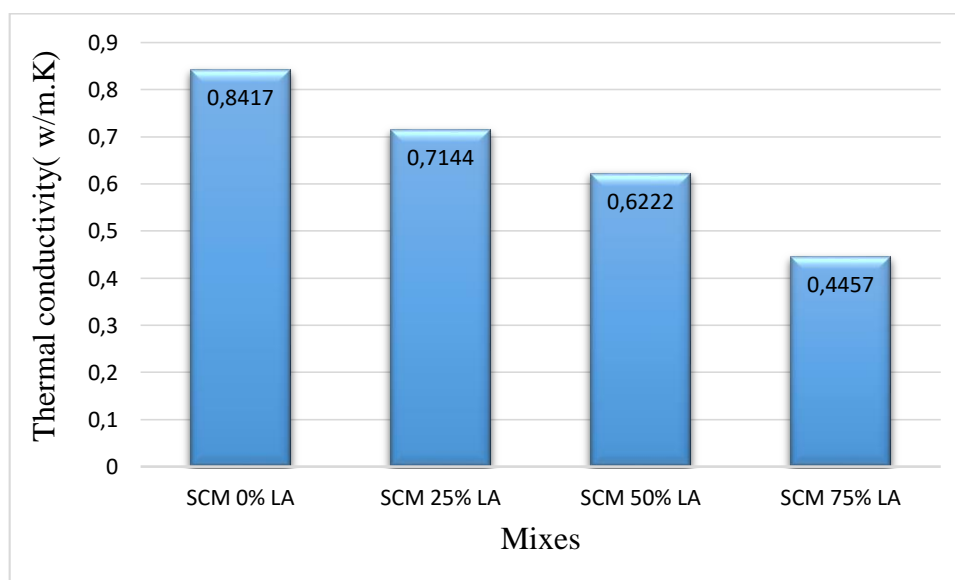

Figure 3.12: Thermal conductivity

Table 3-10: Results of thermal conductivity of ordinary mortar mixes

Mixes	Conductivity (w/m.K)	Relative conductivity to reference mix (%)
OM 0% LA	1,1193	100
OM 25% LA	0,8039	71.82
OM 50% LA	0,7076	63.22
OM 75% LA	0,7071	63.17

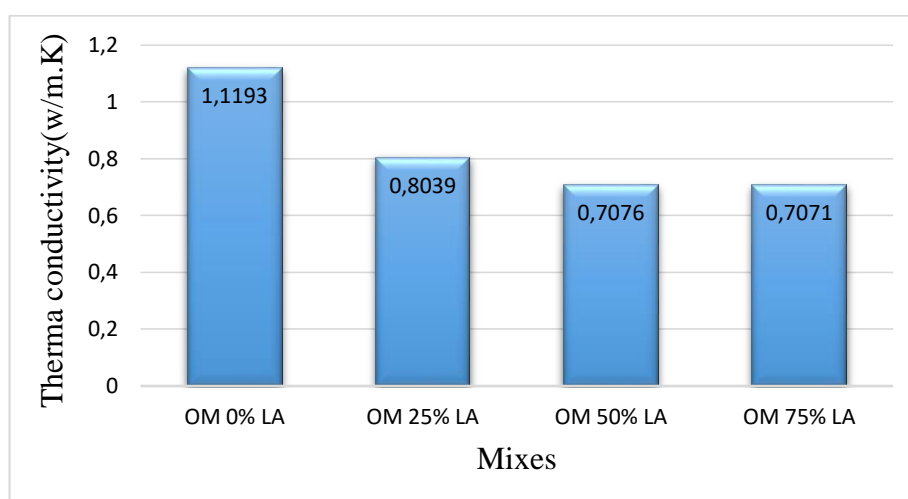

Figure 3.13: Thermal conductivity of ordinary mortar mixes

These figures and tables showed that the conductivity of self-compacting mortar mixes is lower than that of ordinary mortar mixes. This could be probably to the lack of vibration of SCM mixes.

The previous figures and tables show clearly that there is decrease in thermal conductivity with the increase for lightweight sand in the mixes. The decrease in conductivity for self-compacting mortar mixes was 15%, 26% and 47% for respectively rates of substitution of natural sand by lightweight sand of 25%, 50% and 75%. The reductions for ordinary mortar mixes were 28%, 37% and 37% for respectively 25%, 50% and 75% of lightweight sand content. The decrease of conductivity is due to the lower conductivity of lightweight sand as compared to natural sand.

The presence of light aggregates in the mortar significantly reduces the thermal conductivity coefficient, allowing better insulation thermal and hence the mortar with lightweight sand could be used in rendering of masonry walls and screed for roofs.

3.9 Water capillary absorption

The water capillary absorption results for self-compacting mortar shows in figure (3.14).

It can clearly seen that the absorption of water of 0% lightweight aggregate mortar (based on natural aggregates) present the lowest water capillary absorption. The mortar based on expanded clay absorb more water thanks to the porous nature of the aggregate structure. The water capillary absorption is more than doubled for mixes with 50% and 75% pf lightweight sand. This could hinder its durability and its outdoor applications. However, the increase for 25% lightweight sand content is slight.

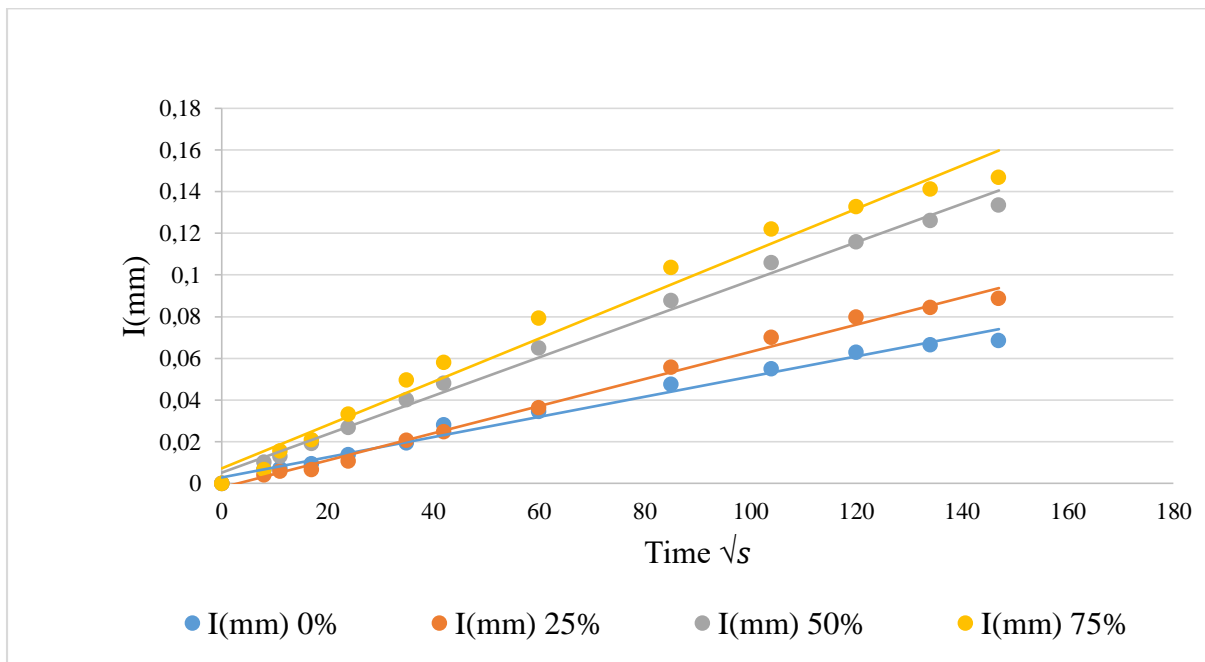

Figure 3.14: Capillary water absorption of SCM

3.10 Conclusion

In this study, the effect of expanded clay aggregates on the characteristics of ordinary and self-compacting mortar has been studied. The following conclusions could be drawn:

- ✓ The compressive strength at 28 days for reference mortar is much higher than any light mortar made ($R_{c28} = 61.4$ MPa) higher than lightweight mortar with 75% ($R_c = 53.33$ MPa).
- ✓ The flexural strength of lightweight mortar is also lower than that of ordinary and self-compacting mortar.
- ✓ The capillary water absorption of self-compacting and ordinary mortar lower than the absorption of lightweight mortar.
- ✓ Better thermo-insulating capacity. Thermal of ordinary mortar ($\lambda = 1.1193$ w/m.k) and the thermal of lightweight mortar with 75% ($\lambda = 0.7071$ w/m.k).

GENERAL CONCLUSION

The work presented in this dissertation is the performance of lightweight mortar with expanded clay.

The literature review show that the characteristics of the light aggregates affect directly those of lightweight mortars. The density of ordinary mortar varies from 2200 to 2600 kg/m³ while that of light mortar varies between 800 and 2100 kg/m³.

Based on the results obtained from the experimental investigation, it can be concluded that:

- The mortar of light aggregates has a low density that translates by a significant profit in terms of the permanent load of the structure.
- Lightweight insulating mortars or concretes have low mechanical performance.
- Light mortars have low thermal conductivity (thermal conductivity of approximately (0.1 – 0.3 w/m·K).

The experimental study was limited by the available time and we propose some further studies such as:

- Mechanical and insulation performances of masonry walls with joint and render lightweight mortar.
- Lightweight self-compacting mortar for roof applications.
- Development of repair mortar with and without fibers for old buildings.

REFERENCES

- [1] SADOUNI Asma et BOURNANE Narimene, Formulation et propriete thermique d'un mortier a base des granulats legers, Mémoire de master, Université de Blida 1, 2020.
- [2] J. D. C. Kumar and E. Arunakanthi, "The use of light weight aggregates for precast concrete structural members," vol. 13, no. 10, pp. 7779–7787, 2018.
- [3] "Chapter 3 physical properties of structural lightweight aggregate," 2007.
- [4] Satish Chandra and Leif Berntsson, "lightweight aggregate concrete" , Chalmers University of Technology Göteborg, Sweden, II. Title. III. Series,2002.
- [5] v. r. tosee, "soil structure interaction journal (ssij) using scoria as fine aggregate in lightweight mortar and concrete," no. 1, pp. 53–60, 2018.
- [6] Robert. Lewis, Lindon Sear, Peter. Wainwright, and Ray Ryle, advanced concrete technology, "Cementitious additions" , volume 3, p 3-66,2003.
- [7] L. Senff, D. Hotza, and J. A. Labrincha, "Effect of diatomite addition on fresh and hardened properties of mortars investigated through mixture experiments," vol 110, no 3,2011.
- [8] S. António, J. Maria, F. Inês, I. Laura, D. E. B. Jorge, and G. M. José, "Water-resistance of mortars with lightweight aggregates," vol. 634, pp. 46–53, 2015.
- [9] J. J. Sloan, P. A. Y. Ampim, R. I. Cabrera, W. A. Mackay, and S. W. George, Advances in Applied Ceramics "Moisture and nutrient storage capacity of calcined expanded shale," January, pp. 28–42, 2014.
- [10] R. Siddique, Waste Materials and By-Products in Concrete. "Waste Glass" pp. 147–148, january2008.
- [11] K. Aeslina, A. Kadir, U. Tun, H. Onn, and A. Mohajerani, "Bricks : An Excellent Building Material for Recycling Wastes" November 2018.
- [12] S. M. A. E. F. S. H. M. S. Amin, "Thermal resistance of hardened cement pastes containing vermiculite and expanded vermiculite," 2011.
- [13] J. Verne à Amiens, "Ce travail a été réalisé dans le cadre d'une co-tutelle de thèse entre l'Université de Picardie".

- [14] Le Hung NGUYEN, bétons de structure à propriétés d'isolation thermique améliorées : d'isolation approche expérimentale et modélisation numérique ,thèse de doctorat de l'université de cergy-pontoise pontoise spécialité Génie Civil , 2013.
- [15] C. Véronique, "Propriétés mécaniques , thermiques et acoustiques d ' un matériau à base de particules végétales : approche expérimentale et modélisation théorique," June, 2014.
- [16] W. Proceedings and F. A. Nordic, "Structural lightweight aggregate concrete," no. 15, 2019.
- [17] D. Srinivasarao, T.Nagalakshmi, E.Anjireddy, R.Dinesh, B.Saiganesh, M. Suresh Kumar Reddy.Studies On Strength Properties of Expanded Clay Aggregate Concrete Bricks.International Journal of Latest Technology in Engineering, Management & Applied Science (IJLTEMAS) Volume VIII, Issue III, March 2019 .
- [18] B. Ayati, V. Ferrándiz-mas, D. Newport, and C. Cheeseman, "Use of clay in the manufacture of lightweight aggregate," pp. 1–22.
- [19] C. Iv, L. E. S., E. T., and I. V ,Les Mortiers, "Cours Matériaux De Construction," pp. 1–13.
- [20] BOUALI Khaled, Elaboration et caractérisation thermomécanique des mortiers à base d'ajouts de déchets de briques réfractaires, "Faculté des Sciences de l'Ingénieur Mémoire de Magister " Mémoire fin d'études, pp. 1–109, 2014.
- [21] "Mortier léger prêt à l'emploi isolant & fibré 500 kg/m³," Edil. Fr., pp. 1–6.
- [22] BAL Nourhane et KHALDI Maroua, the use of local aggregates for the manufacture of mortar and screed, master dissertation ,speciality: Materials in civil engineering ,pp 34,2021.
- [23] ZANE Messaouda DJEMAA Nabila, "Elaboration et caractérisation d'un mortier léger par introduction de billes de polystyrène.," Mémoire fin d'études, pp. 1–103, 2019.
- [24] G. Mohamed and B. Djamila, "Physical and mechanical properties of cement mortar made with brick waste," vol. 01077, pp. 1–5, 2018.
- [25] D. Taoukil, Y El meski ,M.I Lahlaouti, R. Djedjig, A.El bouardi, "Effect of the use of

- diatomite as partial replacement of sand on thermal and mechanical properties of mortars,” *Journal of Building Engineering* 42 (2021) 103038 .
- [26] V. Corinaldesi, A. Mazzoli, and G. Moriconi, “Mechanical Behaviour and Thermal Conductivity of Mortars with Waste Plastic Particles,” vol. 466, pp. 115–120, 2011.
- [27] M. Leyton-Vergara, A. Pérez-Fargallo, J. Pulido-Arcas, G. Cárdenas-Triviño, and J. Piggot-Navarrete, “Influence of granulometry on thermal and mechanical properties of cement mortars containing expanded perlite as a lightweight aggregate,” *Materials (Basel)*., vol. 12, no. 23, pp. 1–17, 2019.
- [28] K. Erdođdu and P. Türker, “Effects of fly ash particle size on strength of Portland cement fly ash mortars,” *Cem. Concr. Res.*, vol. 28, no. 9, pp. 1217–1222, 1998.
- [29] M. Małek, W. Łasica, and M. Jackowski, “Effect of waste glass addition as a replacement for fine aggregate on properties of mortar,” pp. 1–19, 2020.
- [30] S. Arivalagan, “Experimental analysis on light weight,” *Exp. Anal. Light Weight Concr.*, vol. 2, no. 1, pp. 1–8, 2018.
- [31] S. K. M.Ramya, “Experimental study on light weight concrete using leca (light weight expanded clay aggregate),” *Int. Res. J. Eng. Technol.* pp. 1–6, 2020.
- [32] S. Akçaözođlu, “The effect of elevated temperature on the lightweight concrete containing waste PET aggregate” 2017.