



**People's Democratic Republic of Algeria**

الجمهورية الجزائرية الديمقراطية الشعبية



**Ministry of Higher Education and Scientific Research**

وزارة التعليم العالي والبحث العلمي

**University of Blida 1**

جامعة البليدة 1

**Submitted to the Department of Mechanical Engineering to obtain a**

**Master's in**

**Energetic Facilities and Turbomachinery**

# **ENERGETIC STUDY OF THE MODULAR PRECESSING PLANT N°03 OF HASSI R'MEL**

**Presented by:**

- CHETTOUM Billel
- LOUAFI Merouan

**Supervised by:**

- Dr. M. ROUDANE

2020/2021

# Dedications

This thesis is dedicated to:

The sake of Allah, my Creator and my Master,

My great teacher and messenger, Mohammed (Peace be Upon Him), who taught us the purpose of life,

The University; my second magnificent home;

My dear parents, my father who has been nicely my supporter until my research was fully finished, and my beloved mother who, for months past, has encouraged me attentively with her fullest and truest attention to accomplish my work with truthful self-confidence,

My dearest fiancée, who leads me through the valley of darkness with light of hope and support,

My beloved brothers; particularly, Mohamed, who helped me out in this thesis,

My friends who encourage and support me,

All the people in my life who touch my heart, I dedicate this thesis.

*Billel*

I dedicate this project to Allah Almighty my creator, my strong pillar, my source of inspiration, wisdom, knowledge and understanding. He has been the source of my strength throughout this program.

My dear father who has encouraged me all the way and whose encouragement has made sure that I give it all it takes to finish that which I have started.

To my brothers and sisters for their everlasting support.

To my professors and especially our promoter and all of the university's staff.

Thank you. My love for you all can never be quantified. May Allah bless you.

*Merouan*

## **Acknowledgement:**

The realization of this thesis was possible thanks to the help of God Allah, our creator, who gave us the strength and perseverance to realize this work. And also of several people to whom we would like to express our gratitude.

First of all, we would like to express our gratitude to our promoter of this thesis, Dr. RODANE Mohamed, for his patience, his availability and especially his judicious advices, which contributed to feed our reflection.

We also wish to thank the professors of the University of Saad Dahleb, who provided the tools and logistics that are necessary for the success of our academic studies.

We would like to give special thanks to the co-promoter Mohamed Chettoum, who was the first to introduce us to the subject that guided our thesis.

We would like to express our gratitude to the friends and colleagues who gave me their moral and intellectual support throughout our process, as well as all the staff of the Regional Direction of Hassi R'mel SONATRACH, in particular, the team of the XP division.

Also, we would like to thank our parents, brothers for their support since our childhood, and I Billel would like to personally thank someone very special to me I. A, Ben Djebbour.

Finally, we would like to express our gratitude to Mr. TEMMAR Mustapha the head of the department, and the professors of the department, for their trust and their invaluable support.

*Billel and Merouan.*

## ملخص:

يشكل قطاع المحروقات قطاعًا استراتيجيًا واقتصاديًا واسع النطاق. في الواقع، فإن نشاط إنتاج ونقل المحروقات (الغاز والنفط) مصدر للثروة الاقتصادية المحلية والعالمية، يساهم في تطوير عدة قطاعات ومناطق حول العالم. ومع ذلك، فإن هذا النشاط يستهلك الكثير من الطاقة، لا سيما الطاقة الكهربائية بسبب بنيتها التحتية الكهربائية (المحولات العالية و المتوسطة) ومحركاتها عالية الاستهلاك التي تستخدمها هذه الأنشطة، والتي تعتبر ضرورية في عمليات المعالجة، في هذه الحالة الوحدة 3 التابعة لقطاع حاسي رمل، والتي هي موضوع دراسة طاوقية.

كل هذه العوامل تجعل الطاقة عنصرًا مهمًا في تحكم الميزانيات التشغيلية للشركات في القطاع الصناعي وعلى وجه الخصوص قطاع الهيدروكربونات، وفي الواقع، انخفاض إنفاق الطاقة مصحوبًا بإدارة جيدة العقلانية له تأثير فوري على الميزانية العمومية مما يؤدي إلى العديد من المزايا.

## Résumé :

Le secteur des hydrocarbures constitue un secteur stratégique et économique de grande envergure. En effet, l'activité de la production et le transport des hydrocarbures (gaz, pétrole et condensat) source de richesse économique locale et mondiale, contribue au développement de plusieurs secteurs et domaines à travers le monde. Cependant, cette activité est très énergivore en matière d'énergie notamment en énergie électrique de par ses infrastructures électriques (Postes de transformation en haute tension HT et moyenne tension MT) et ses moteurs de grande puissance qu'elle utilise, et qui sont nécessaires dans les process de traitement et de pompage des hydrocarbures en l'occurrence le module 3 faisant l'objet d'un audit énergétique dans le cadre de cette étude.

Tous ces facteurs-là rendent l'énergie un élément important dans la maîtrise du budget d'exploitation des compagnies des secteurs tertiaires et industriels et en particulier le secteur des hydrocarbures. En effet, une réduction des dépenses énergétiques s'accompagnant d'une bonne gestion rationnelle a un effet immédiat sur le bilan financier donnant lieu à plusieurs avantages.

## Abstract:

The hydrocarbons domain is a large strategic and economical sector. In fact, the production and transportation activities of hydrocarbons (Gas and fuels), is a local and international

wealth source, that contributes to the development of so many other sectors and domains all around the globe. In the meantime, this activity requires a lot of energy, especially electrical energy due to its electricity transformers and its high power engines, these equipments are necessary in all the gas processing cycle in Module 03 that will go through an energetic study as part of this thesis.

All these factors make energy a very important element when it comes to budgets of companies in the industrial sector, especially the hydrocarbons domain, moreover, lowering energy consumption and having a good management can immediately result advantages on so many scales.

# NOMENCLATURE

Symbol	Signification
MPP03	Module Processing Plant III
DCS	Distributed Control System [YKW-3000]
ISO	International Standards Organization
HHV	Higher Heating Value
LHV	Lower Heating Value
Ppm	Parts per Million
C5+	Gas Condensate
Bar G	Gauge pressure
Psia	Pound per Square Inch
E	Air excess
Mw	Molecular weight
T/h	Ton Per Hour
$\rho$	Density (fuel gas)
$\gamma$	Heat capacity ratio
Nm <sup>3</sup> /h	Normal Meter Cubed per Hour
EG	Exhaust Gas
Cp	Heat Capacity
G.T.E	Global Thermal Efficiency
NTU	Number of Transferred Units
$\varepsilon$	Effectiveness
STIG	Steam Injected Gas Turbine
STIG/SWC	Combined Cycle
TH	Therm

## TABLE LIST

Table 1.1	Chapter 01	Page 14	Typical specifications
Table 2.1	Chapter 02	Page 19	Raw gas
Table 3.1	Chapter 03	Page 36	Operating parameters MS-5002C
Table 3.2	Chapter 03	Page 40	Operating conditions MS-5002C
Table 3.3	Chapter 03	Page 48	Composition of fuel gas
Table 3.4	Chapter 03	Page 49	Mass of O2 to burn fuel gas
Table 3.5	Chapter 03	Page 61	Operating parameters MS-3002J
Table 3.6	Chapter 03	Page 62	Operating conditions MS-3002J
Table 3.7	Chapter 03	Page 77	CO2 emissions

## LIST OF FIGURES

Figure 1.1	Chapter I	Page 8	SONATRACH – DP Laghouat
Figure 1.2	Chapter I	Page 9	Geographical Location
Figure 1.3	Chapter I	Page 9	The Hassi R'mel Gas Field
Figure 1.4	Chapter I	Page 16	PRITCHARD Process
Figure 1.5	Chapter I	Page 17	HUDSON Process
Figure 1.6	Chapter I	Page 17	The Steps of HUDSON Process
Figure 2.1	Chapter II	Page 31	MPP3 Process scheme
Figure 2.2	Chapter II	Page 32	MPP3 Process scheme
Figure 3.1	Chapter III	Page 34	Energy Diagram of the Module
Figure 3.2	Chapter III	Page 37	Theoretical Cycle of Brayton
Figure 3.3	Chapter III	Page 39	Characteristics of the MS-5002C
Figure 3.4	Chapter III	Page 40	MS-5002C Gas Turbine
Figure 3.5	Chapter III	Page 43	Flow diagram of the MS-5002
Figure 3.6	Chapter III	Page 43	Influence of ambient temperatures
Figure 3.7	Chapter III	Page 45	Photo taken of the ovens
Figure 3.8	Chapter III	Page 45	DCS Diagram
Figure 3.9	Chapter III	Page 46	Cabin ovens with horizontal tubes
Figure 3.10	Chapter III	Page 51	DCS with operating parameters
Figure 3.11	Chapter III	Page 52	Cylindrical Oven
Figure 3.12	Chapter III	Page 54	DCS H301
Figure 3.13	Chapter III	Page 56	Scheme of HE
Figure 3.14	Chapter III	Page 56	Principle of HE
Figure 3.15	Chapter III	Page 58	DCS of the HES
Figure 3.16	Chapter III	Page 58	CC exchangers (HP side)
Figure 3.17	Chapter III	Page 60	GT MS-3002J
Figure 3.18	Chapter III	Page 62	Characteristics of the MS-3002J
Figure 3.19	Chapter III	Page 63	Brayton Cycle
Figure 3.20	Chapter III	Page 64	Energy Flow Diagram MS-3002J



Figure 3.21	Chapter III	Page 65	Influence of ambient temperature
Figure 3.22	Chapter III	Page 67	Turbine cycle with Wet cycle
Figure 3.23	Chapter III	Page 68	Turbine cycle with STIG
Figure 3.24	Chapter III	Page 69	Turbine cycle with recovery system
Figure 3.25	Chapter III	Page 70	Thermodynamic cycle of recovery system
Figure 3.26	Chapter III	Page 71	Problem data ISO given by SONATRACH

## **PREAMBLE**

With the increase in electricity prices, energy consumption is becoming an increasingly significant factor in the production costs of industrial companies. If, in the past, the aspects related to the operation of the production line were somewhat relegated to the background, the concerns tending to the elimination of polluting factors and to the cost reductions in general, today, in a competitive environment marked by a very strong competitiveness become important. To this end, the analysis of consumption becomes vital in order to identify potential improvements and the resulting savings. While working to continuously improve the availability and capacity of installations, management techniques also aim to improve performance in terms of organization, identifying productivity gains and hunting down excess costs. Measurement, metering, analysis... are the key words in an energy audit. This audit study consists precisely in dissecting all these terms with the objective of controlling and rationally using energy, which has a direct impact on both the macro and microeconomic levels, resulting in substantial savings, improvements in equipment performance and efficiency and a contribution to environmental protection. In addition to this study, the audit allows the gas production company to prepare the ground for a possible certification in energy management ISO 50001, a certification that has become necessary especially for the hydrocarbon sector in a global energy context aiming at cost control and reduction of the environmental impact related to this activity (reduction of greenhouse gases).

# SUMMARY

**Dedications**

**Acknowledgments**

**Abstract**

**Nomenclature**

**Table\_list**

**Figures\_list**

**Preamble**

APPROACH.....	1
Work plan.....	2
Definitions.....	3
<b>Chapter I: Identification of the company, the module and the auditor.....</b>	
Presentation of the SONATRACH company.....	5
Geographical situation of the HassiR'mel field.....	8
History of the development of the HassiR'mel field.....	9
The activities of the HassiR'mel field.....	10
Pritchard process.....	13
Hudson process.....	14
<b>Chapter II: Working principle of the MPP03.....</b>	
Raw gas and final product specifications.....	17
Different sections of the MPP03.....	19
Boosting section.....	19
Raw gas treatment section.....	19
Glycol storage and injection section.....	19
Glycol re-generation section.....	20
Utilities section.....	21
Gas recompression section K002.....	22
Gas section and product storage.....	22
De-propanization section.....	22
Fuel gas.....	22
Torch section.....	23
Analysis section.....	23
Electricity section.....	24

Natural gas treatment techniques.....	24
Gas re-injection techniques.....	26
Organization of the MPP03.....	27
Description of the MPP03 gas treatment process.....	28
<b>Chapter III: Operating data and exploitation.....</b>	
Energetic study of the module and the different sectors.....	33
The main energy consuming equipment in the complex.....	34
The MS-5002C turbines (boosting).....	34
Energetic study of the MS-5002C turbines.....	39
Energetic study of the ovens (03 trains X 02 ovens) DEETHANIZER.....	43
Energetic study of the H801 ovens.....	49
Energetic study of the boilers.....	51
Heat exchangers of train C (high pressure side).....	53
The MS3002J turbine of the sales gas compression.....	57
Energetic study of the MS3002J turbines.....	59
Important solutions regarding the gas turbines.....	62
Wet compression WC.....	62
Steam injected gas turbine.....	63
Combined cycle (STIG and SWC cycles).....	64
Installation of an air heater.....	65
Summary results after the installation of an air heater.....	69
Conclusion concerning the study carried out on the turbines.....	70
Evaluation of the energy management system.....	71
Energy action plan.....	72
Impact on the environment.....	73
<b>CONCLUSION.....</b>	<b>75</b>
References.....	76

## **APPROACH:**

During our visit, we were able to:

1. Discuss, during the opening meeting, the objectives of the energy control with the managers and the personnel at the plant, in particular the personnel of the exploitation; maintenance and HSE.
2. Obtain documentation of turbines; heat exchangers; furnaces and boilers.
3. To visit the installations accompanied by personnel who know the processes well. During the visit we were able to identify:
  - The main energy consuming areas, which will need to be studied.
  - The existing meters and the deficiencies in energy metering.
  - The tools needed for the audit. And also collect some basic data needed for the audit.

Another step is the evaluation of the situation: First, a reference period is defined, i.e. a representative time interval from the point of view of the energy consumption of the site, and then its analysis is carried out according to two levels of detail, which consists of drawing up the energetic study of the site, as well as that of the different sectors.

The global energetic study gives a picture of the energy and material flows of the plant and locates the major energy consumers.

The sector balances will illustrate the energy and material flows in and out of the sector under consideration. In accordance with this methodology, we requested a three-year statement of the monthly quantities of raw gas; gas consumed as well as the quantities of products delivered.

All the requested data were put at our disposal and all our interrogations found answers and details at the questioned personnel who showed from the beginning a will and a remarkable availability to help us to realize this work.

Notwithstanding the short time reserved for the visit of the sites, the explanations given by the personnel at the level of the module on the one hand and the exploitation of the documents put at our disposal thereafter on the other hand, allowed us to elaborate a work plan specific to the unit (without this specific plan, it would have been impossible for us to realize this work).

## **Work plan:**

The plan based primarily on production data; operational constraints and maintenance issues consists of:

1. Identification of the system, the sectors and the representative period;
2. Exploitation of the documents at our disposal at the unit level to be able to weigh the energy contribution in the treatment of the raw gas;
3. Cross-reference and explain any discrepancies with the data collected at the central level
4. Assessment of the energy input for the whole unit and then per machine based on the consumption and the specific cost of the products.

## **DEFINITIONS**

For this work, we use the following definitions:

- **The system:** The module is the system inside which energy flows enter in three forms (natural gas, electricity and diesel). All the energy flows directly used or having undergone a treatment, are delivered to the final consumption within the module.
- **The sector:** To study the structure of this consumption, the module will be segmented into a number of entities called "sectors". Each sector will correspond to a set of machines whose energy consumption is significant.
- **The reference period:** This is a representative time interval, from the point of view of energy consumption, the analysis will be carried out according to three levels of detail using the data collected at site level and cross-referenced with those validated at central level.
- **Profitability:** The strategy of linking energy efficiency and economic profitability has meant that no energy saving action is acceptable from an economic point of view unless it leads to cost savings. Any savings measure that requires an investment must meet the criteria of profitability. The profitability calculations during an audit focus first on the classification of the identified savings opportunities using simple profitability criteria, such as the investment cost, or the payback time.
- **Payback time:** is expressed in years and gives the number of years needed to recover the capital invested. To be economically justified, the return time obtained must be acceptable,

not only in absolute value but also in relation to the expected longevity of the installed device and the overall installation.

**CHAPTER I**  
**IDENTIFICATION OF THE COMPANY,**  
**THE MODULE AND THE AUDITOR**



**I. Presentation of the SONATRACH Company :**

National Company of research, exploitation, transport by pipeline, transformation and marketing of hydrocarbons and their derivatives.

It also intervenes in the sectors:

- Electricity generation.
- New and renewable energies.
- Desalination of sea water.
- Mining research and exploitation.

SONATRACH was created on December 31, 1963 and occupies the first place as an African oil company as well as a better place on the world scale.

**I.1.Establishment of SONATRACH**

The Evian agreements (March 18, 1962) provided for the establishment of a Saharan organization whose essential task was to propose solutions to oil issues and to oversee the development of the Saharan infrastructure.

However, the Saharan oil code, which was specially revised before July 1962, offered a virtual monopoly on Algerian oil to French companies and granted them significant fiscal advantages at the expense of the Algerian Treasury.

It is for this reason that one of the first acts of the Algerian state, after independence, concerned the hydrocarbon sector. It provided itself with an instrument to implement its energy policy by creating, on December 31, 1963, by decree n° 63/491, the National Company for the Transport and Marketing of Hydrocarbons: SONATRACH.

**I.2. SONATRACH's development phases:**

- 1963 - 1971: Creation and construction of SONATRACH
- 1971 - 1982: Growth and integration phase
- 1982 - 1987: Restructuring and spin-off
- 1987 - 1998: Maturity and modernization

- 1998 - 2000: New statutes organizing SONATRACH as a joint stock company

(Spa)

- 2000 to date: Redeployment and development.

SONATRACH's missions: The missions entrusted to SONATRACH by the State, sole shareholder, are the following

- To contribute to the national development by maximizing the long term hydrocarbon resources in Algeria;
- To satisfy the current and future needs of Algeria in hydrocarbons and petroleum products;
- To contribute to the national development in particular by providing it with the necessary foreign currency.

### **I.3 SONATRACH's business lines:**

SONATRACH's core businesses cover the entire hydrocarbon chain, from research and exploration to the processing of hydrocarbons and their marketing to end consumers.

These activities can be grouped into four global businesses:

- Upstream oil;
- Downstream oil and gas;
- Pipeline transportation;
- Marketing of hydrocarbons and petroleum products.

We will present them briefly:

#### **a) Upstream oil**

- Exploration;
- Drilling;
- Well services;
- Field development;

- Field exploitation.

**b) Downstream oil**

- Natural gas liquefaction ~ LPG separation;

- Refining;

- Petro-chemistry.

**c) Pipeline transport (TRC)**

- Development and realization of pipelines for the transport of hydrocarbons produced from crude oil, condensate, natural gas and LPG deposits;

- The operation of the pipeline transportation system;

- Maintenance of the pipeline transport system.

**d) Marketing**

- The marketing of hydrocarbons and petroleum products on the international and national markets.

- Trading and shipping of hydrocarbons (SONATRACH has a large fleet of LNG carriers, LPG carriers and oil tankers). [1]

I.4 SONATRACH: Exploitation-Division Production Hassi R'Mel Wilaya of Laghouat:

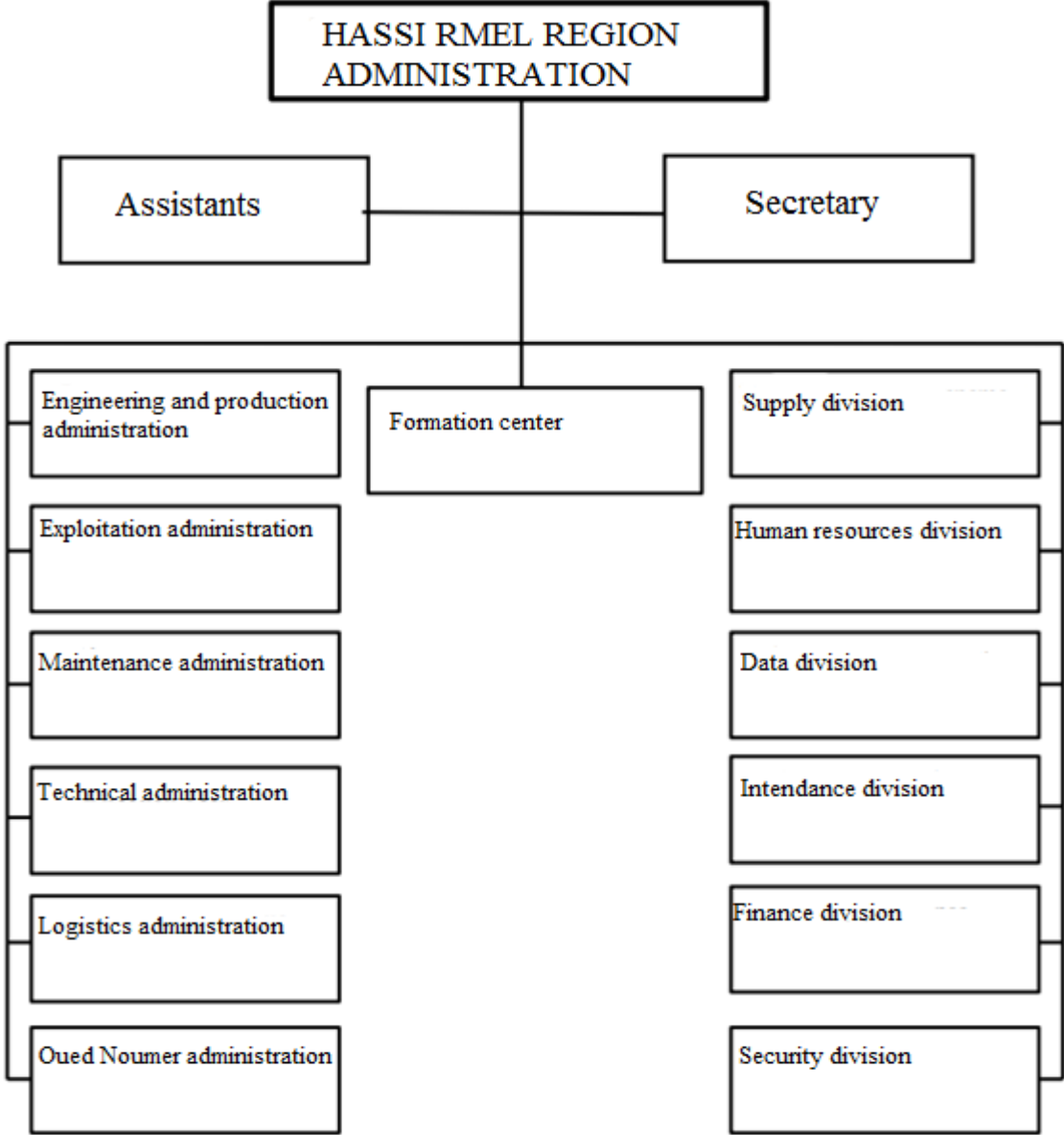

Figure 1.1: SONATRACH - Production Division Hassi R'Mel Wilaya of Laghouat

**I.5.Geographical situation:**

The region of Hassi-R'mel is located 550 km south of Algiers at an altitude of 760m; the landscape is a vast rocky plateau. The climate is characterized by an average humidity of 19% in summer and 34% in winter, the temperature is very important there going around 20°C.



Figure 1.2: Geographic location

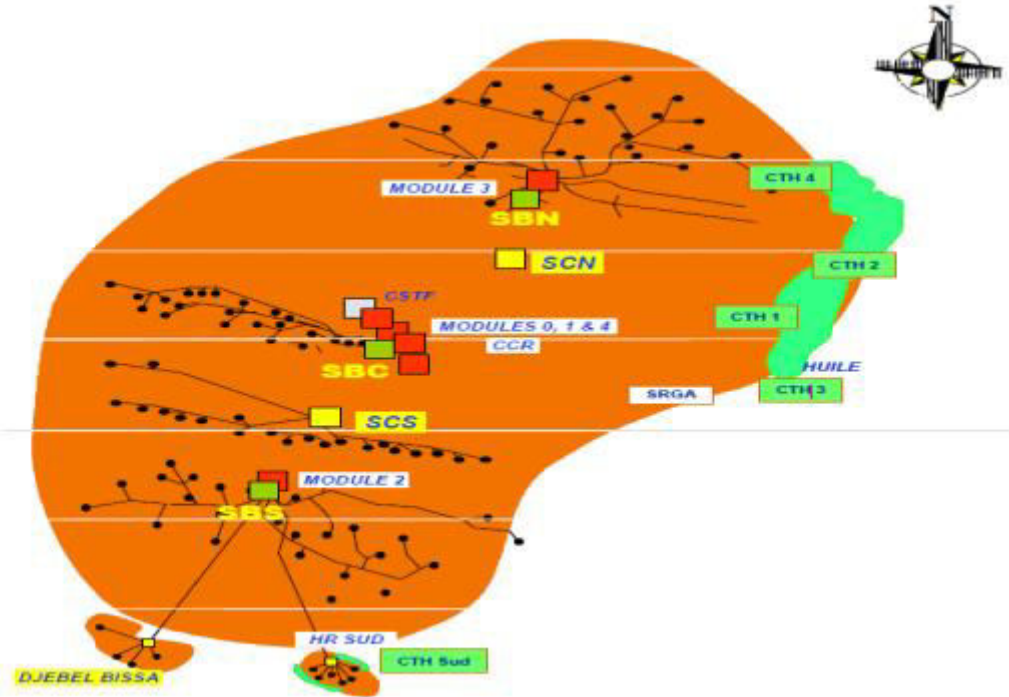

Figure.1.3. The Hassi-R'mel gas field

## **I.6. HISTORY OF THE DEVELOPMENT OF THE HASSI R'MEL FIELD**

The HassiR'mel deposit was discovered in 1956 by drilling the first well HR-1, at a depth of 2132m, and which revealed the presence of a wet gas reservoir under high pressure (309 bars at the bottom).

- From 1957-1960: eight other wells were drilled for the delimitation of the deposit and the evaluation of the reserves initially estimated at 2800 billion m<sup>3</sup> under an area of 3500 square kilometers.

- 1961: Realization of a small gas processing unit of 1.3 billion m<sup>3</sup> per year. This achievement coincided with the construction of a new gas liquefaction plant in 1964.

- 1964: This capacity is increased to 4.4 billion m<sup>3</sup> per year.

- 24-02-1971: Historic nationalization of hydrocarbons which allows the increase of the processing capacity of HassiR'mel to 14 billion m<sup>3</sup> per year.

- 1975: SONATRACH implements a master development plan to increase production capacity to 94 billion m<sup>3</sup> per year and maximize the recovery of liquid hydrocarbons through partial gas recycling. Achieving these objectives required the implementation of:

- Four gas processing plants with a unit nominal capacity of 20,109Sm<sup>3</sup>/year of dry gas named modules (I-II -III -IV).

- Two gas reinjection stations with a nominal capacity of 30 billion m<sup>3</sup>/year of dry gas (North and South stations).

- A storage and transfer center for condensate and LPG (CSTF) with a capacity of 80,000 m<sup>3</sup> of LPG and 285,000 m<sup>3</sup> of condensate.

- Installation of a collection network of more than 2,000 km.

- Construction of a road network of more than 400 Km to serve the wells and the surface installations.

- 1985: Completion and implementation of the common plant to recover medium and low pressure gases and produce LPG from modules 0 and 1.

●1981/1993: Realization and implementation of five crude oil processing centers named CTH 1-2-3-4 and south for the exploitation of the oil ring of HassiR'mel.

●2000: Realization and implementation of the HR-SUD gas processing center. The final development of the HassiR'mel field has achieved the following production capacities:

- 100 billion m<sup>3</sup> of gas /year.
- 12 billion tons of condensate/year.
- 2.5 million tons of LPG/year.
- 700 thousand tons of crude oil /year.

### **I.7. The activities of the HassiR'mel field:**

#### **- Module**

It is the diminutive of "module processing plant" which designates a processing unit, it consists of a set of equipment (03 Trains) designed and built to allow a specific treatment of gas, condensate and LPG, in accordance with an appropriate process and meeting the commercial specifications.

Five modules are located in HassiR'mel. Four have a unit capacity of 60 million m<sup>3</sup> /day. The fifth is the "0" module which has a capacity of 30 million m<sup>3</sup> /day. A sixth module serves the small deposit of "DjebelBissa", with a modest capacity of 6 million m<sup>3</sup> /day. It is referred to as a gas processing center. The gas processing modules are connected to the CSTF storage center for the storage of liquids.

#### **- Storage and Transfer of Hydrocarbons**

All the condensate and LPG produced by the different modules and CTG are sent to the CSTF: "central storage and transfer facilities" which is a storage and transfer center for liquid hydrocarbons located in the central area of HassiR'mel. They undergo a final decantation to remove any residual water, before being sent through a metering system to Arzew by means of a 28-inch pipeline for condensate and 24 inches for LPG.

#### **- CNDG: (The national center of gas dispatching)**

It is made up of a set of installations " pipelines, automatic valves, regulation equipments, counting equipments...etc " controlled from a control room and which allow the recovery of

all the gas produced in the Algerian south and in HassiR'mel and its distribution towards the various recipients:

- The power stations of electricity production.
- The NG liquefaction plants in Arzew and Skikda.
- Gas pipelines serving Italy via Tunisia.
- Gas pipelines serving Spain via Morocco.
- The gas compression and reinjection stations in the fields of HassiR'mel.
- The domestic and industrial consumption of the country.
- Boosting station

The production history shows a decrease in reservoir pressure in accordance with the withdrawal schedule. The gas processing units are designed to operate at a minimum inlet pressure of 100 bars. Taking into account these two parameters, boosting is an unavoidable necessity.

Given the withdrawal profile considered, the Boosting deadline has been pushed back to 2003, with the following actions:

- Drilling of additional wells.
- Putting into operation the W8 collector on Module 3, 4.
- Modification of the existing collection network.

**The project consists of the realization of:**

The drilling of 59 wells distributed over the three zones: Center, North and South. This number 59 has been optimized by model. A new collection network and the modification of the existing collection network to make it compatible with the new service parameters of the modules from the year 2003.

Three Boosting stations located at Module 2, Module 3 and the central area grouping Modules 0, 1 and 4



**- The Boosting Station:**

The purpose of reinjection of dry gas at the level of the deposit is to maintain pressure and this in order to recover the maximum of liquids (LPG and condensate).

The re-injection capacity of each unit of the two compression stations, North and South, is 90 million standard m<sup>3</sup> /day.

**- Associated Gas Recovery Station (AGRS):**

This unit started on April 18, 1999 with a capacity of 4 million m<sup>3</sup> /day

**I.8 Natural gas processing techniques:**

The treatment of natural gas consists in separating the constituents present at the exit of the wells such as water, acid gas, and heavy hydrocarbons to bring the gas to transport specifications or commercial specifications.

The allocation of these treatments between production and delivery locations is based on economic considerations.

It is generally preferable to perform only those treatments at the production site that make the gas transportable.

The main treatments that are carried out are:

- A first step allows the separation of liquid fractions that may be contained in the well effluent: hydrocarbon liquid fractions (associated gas or with free water condensate), and the treatment step that follows depends on the mode of transportation adopted.
- Natural gas and its various fractions can be transported in the form of:
  - Compressed natural gas (transport by pipeline).
  - Liquefied petroleum gas (LPG).
  - Liquefied natural gas (LNG).
  - Various chemicals (methanol, ammonia, urea, etc.).

Some components of natural gas must be extracted either for reasons imposed by the subsequent processing or transportation stages, or to comply with commercial or regulatory specifications.

- It may be necessary to remove at least some of the following
  - Hydrogen sulfide H<sub>2</sub>S: toxic and corrosive.
  - Carbon dioxide CO<sub>2</sub>: corrosive and of zero thermal value.
  - Mercury: corrosive in certain cases.
  - Water leading to the formation of hydrates.
  - Hydrocarbons that condense in transport networks.
  - Nitrogen: of zero thermal value.

The specifications to be respected for the treated gas are related to the conditions of transport by pipeline, these specifications of transport aim at avoiding the formation of a liquid phase (hydrocarbon or water), the blocking of the pipe by hydrates and a too important corrosion.

In this case, a maximum value is imposed on the dew points (water and hydrocarbons).

The value of the hydrocarbon dew point depends on the transport conditions and can be set for example at -5°C to avoid any risk of liquid phase formation by retrograde condensation.

More severe and also include a range in which the calorific value must be located. In the case of a commercial gas, the specifications are:

HHV	9300 to 9450 (Kj/m <sup>3</sup> )
Dew Point	Less than -6°C
Water Content	Less than 50ppm Vol.
C5+ Content	Less than 0.4% mol.

**Table.1.1 Typical specifications for commercial gas**

Due to the difference between the transportation and commercial specifications, additional processing may be required before the gas is sent to the distribution network.

The treatment carried out to obtain the transport specifications may be accompanied by a fractionation in order to obtain a liquid fraction including LPG (propane and butane) and possibly ethane.

When it appears advantageous to valorize this liquid fraction separately, in certain particular cases a separation of nitrogen can be necessary and a recovery of helium is possible, if the natural gas contains it.

### **I.9. Gas treatment processes:**

The gas treatment processes are multiple and the choice of the type of treatment is based on the following criteria:

- Quantity of raw effluent.
- Target liquid hydrocarbon recovery rate.
- Specification of the final products.
- Overall investment cost.

### **I.10. PRITCHARD process:**

It is based on the cooling of the gas by heat exchange and expansion with the use of a propane loop as a refrigeration system, to reach at the end of the cycle temperatures around  $-23^{\circ}\text{C}$ .

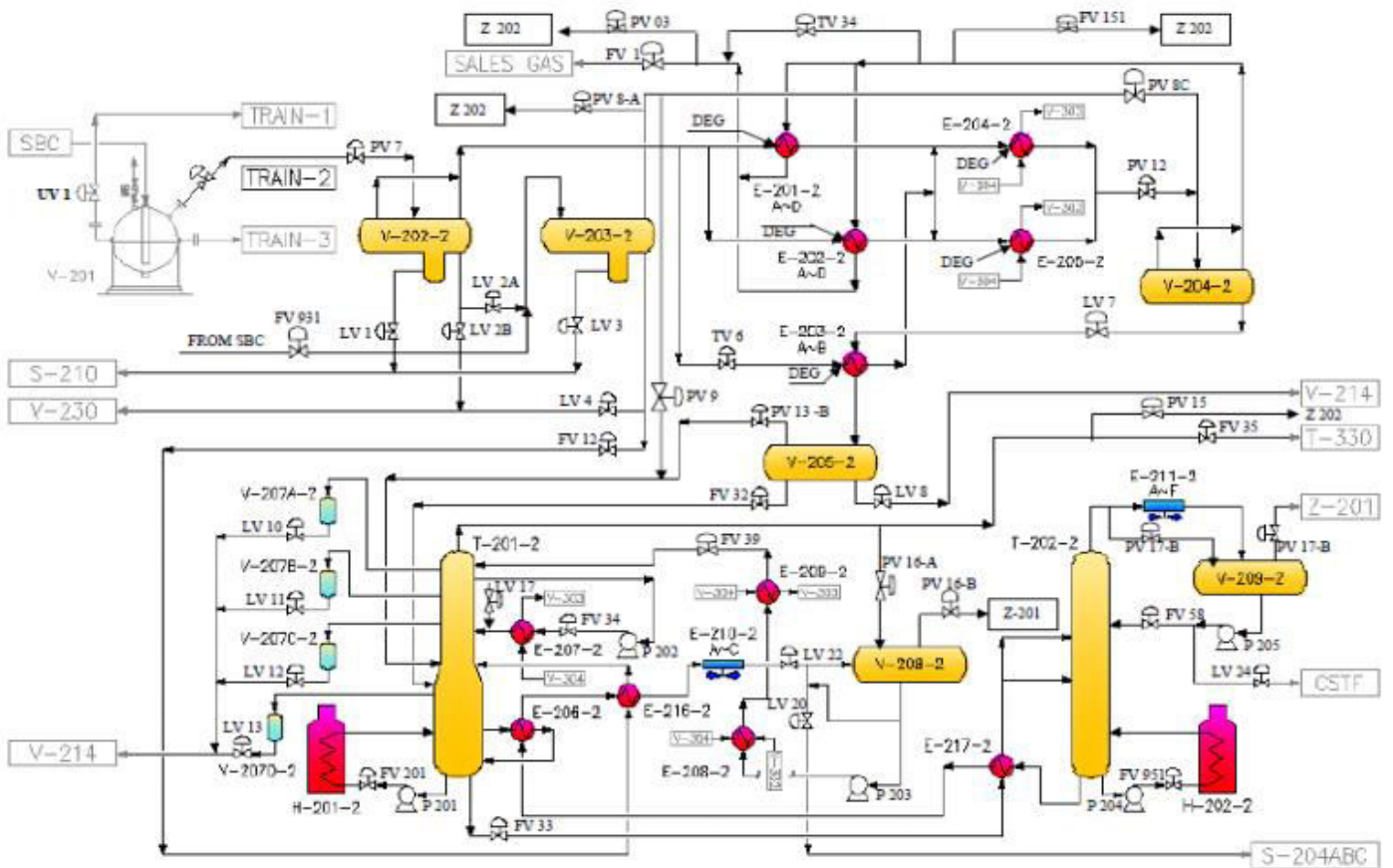

Figure1.4. PRICHARD process [2]

### I.11. HUDSON process:

It is based on the cooling of the gas by heat exchange and by a series of expansions completed by an expansion through a machine called Turbo-Expander, which allows to reach a temperature level of (- 40°C).

The Hudson process is more efficient and allows a better recovery of liquid hydrocarbons.

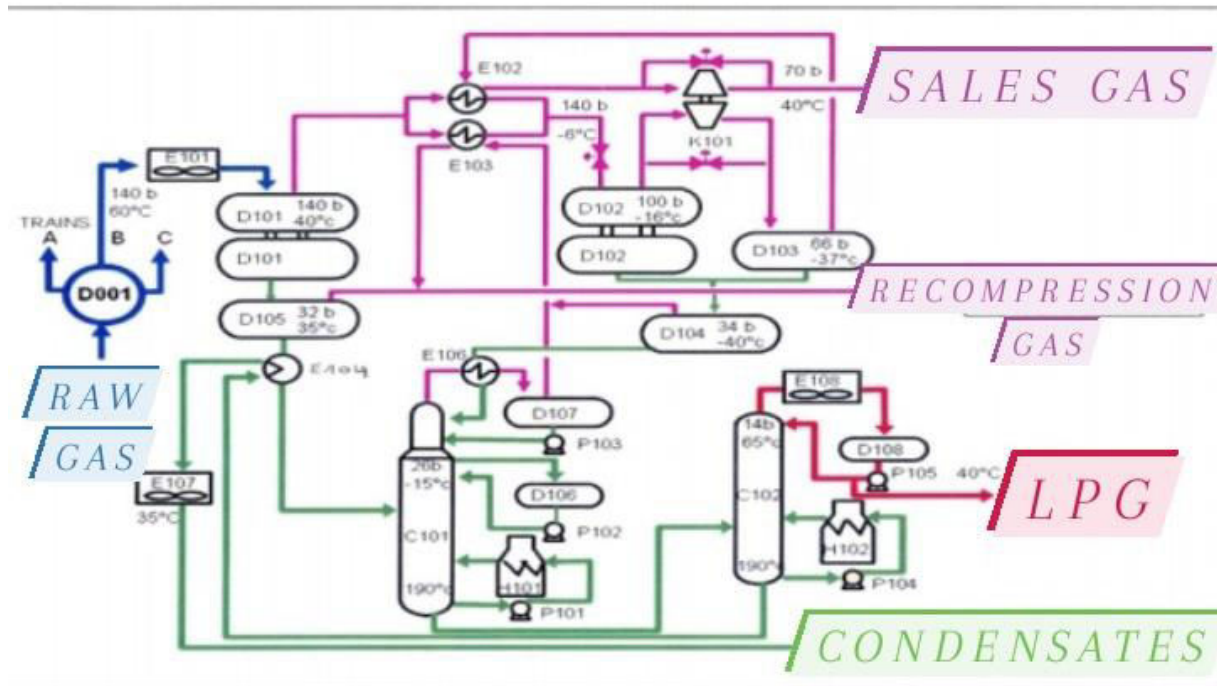

Figure1.5. HUDSON process [2]

HUDSON process steps:

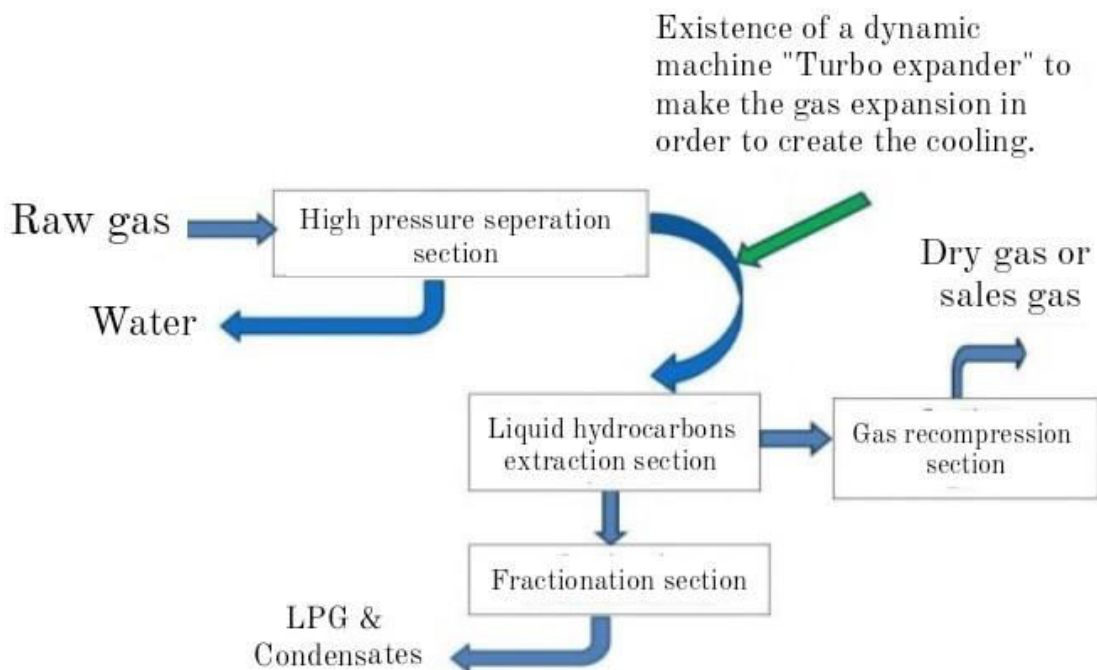

Figure1.6. the steps of the HUDSON process [3]

**CHAPTER II**  
**WORKING PRINCIPLE OF THE MPP03**

## II.1. Raw gas and final product specifications:

### II.1.1. Raw gas specifications:

This plant is designed to process raw gas, the specifications of which are given below:

- Water content:** saturated at 310 kg / cm<sup>2</sup>at 90 ° C.
- Temperature:** min 45 ° C (operation in winter).
- Pressure:** min 100 bars G / max 140 bars G.

The following table shows the final products specifications:

<b>Constituants</b>	<b>% Molaire</b>
N <sub>2</sub>	5.56
CO <sub>2</sub>	0.20
CH <sub>4</sub>	78.36
C <sub>2</sub> H <sub>6</sub>	7.42
C <sub>3</sub> H <sub>8</sub>	2.88
IC <sub>4</sub> H <sub>10</sub>	0.62
NC <sub>4</sub> H <sub>10</sub>	1.10
IC <sub>5</sub> H <sub>12</sub>	0.36
N C <sub>5</sub> H <sub>12</sub>	0.48
C <sub>6</sub> H <sub>14</sub>	0.59
C <sub>7</sub> H <sub>16</sub>	0.56
C <sub>8</sub> H <sub>18</sub>	0.45
C <sub>9</sub> H <sub>20</sub>	0.37
C <sub>10</sub> H <sub>22</sub>	0.27
C <sub>11</sub> H <sub>24</sub>	0.21
C <sub>12</sub> H <sub>26</sub>	0.57
TOTAL	100

Table 2.1: Raw gas composition [2]

### II.1.2. Specifications of the products obtained (design)

- Dry gas**

*Chapter II: Working Principle of the MPP03.*

**Dew point:** - 6 ° C to 80 Kg / Cm<sup>2</sup>

**Water content:** 50 ppm by volume maximum

**HHV:** 9350 - 9450 Kcal / m<sup>3</sup>

**C5 + content:** 0.5 mol% maximum.

**Sales gas pressure:** 71 Kg / Cm<sup>2</sup>

**•LPG**

**C2 content:** maximum 3 mol%.

**C5 + content:** 0.4 mol% maximum.

**•Condensate**

**Reid vapor pressure:** 10 psia (0.7 Kg / Cm<sup>2</sup>).

**II.1.3. Specifications of the products obtained (current)**

We took the annual average for 2016

**•Dry gas**

**Dew point:** - 10.3 ° C to 70.5 Kg / Cm<sup>2</sup>

**Water content:** 26 ppm by volume

**HHV:** 9316 Kcal / m<sup>3</sup>

**C5 + content:** 0.19 mol%

**•LPG**

**C2 content:** 1.61 mol%

**C5 + content:** 0.0 mol%

**•Condensate**

Reid vapor pressure: 10 psia (0.66 Kg / Cm<sup>2</sup>).

All these characteristics are checked daily by analyzes carried out in the laboratory.



## **II.2. Different sections of MPP3 [4]**

### **II.2.1. BOOSTING section**

The raw gas arriving at the manifold goes directly into the separator tanks D901A/B/C. These balloons separate the water, condensate and gas.

- The water is sent to the SPI section,
- The condensate collected is cooled in the E904 dry cooler, and then evacuated directly to the D105 balloons of the 03 trains under the control of the LIC932.
- The gas passes through the D902 A / B and C suction tanks, is made up of the supply of the 03 centrifugal compressors installed in parallel.

The current parameters are: Suction pressure = 56 Kg / Cm<sup>2</sup>, T = 60 ° C. The gas is forced back at 101 Kg / Cm<sup>2</sup> and at T = 78 ° C, cooled in air coolers to 60 ° C. The gas from the BOOSTING section enters the diffuser balloon D001 where it is dispatched in 03 charges identical to supply each of the 03 trains.

### **II.2.2. Raw gas treatment section: Trains 31/32/33**

It is made up of three identical A, B and C trains, each train of which is made up of the part high pressure and fractionation part and ensures the production of the following products: Condensate, LPG and Dry Gas.

### **II.2.3. Glycol storage and injection section**

Natural gas contains water and when the temperature drops under high pressure it risks forming a white body in a solid state called a hydrate, these hydrates being solids which can cause clogging of the heat exchangers or other incidents on the rotating machines.

In this module III, hydrates could form in certain places, so to escape when the latter are formed, a solution of MEG (mono-ethylene glycol) is injected therein.

The MEG lowers the freezing point of the gas and absorbs the water contained in the raw gas, which will prevent the formation of hydrates.

**• Glycol injection points:**

- Raw gas exchanger inlet E102 / E103 (tube side).
- Input expander K101 (currently removed).
- Deethanizer E106 reflux exchanger inlet (tube side).
- C101 Deethanizer reflux line.
- D105 power line (currently discontinued).

**II.2.4. Glycol regeneration section:**

The two units 35 and 36 (two identical units) are designed to regenerate hydrated glycol.

The 73% by weight mono ethylene glycol is preheated by heat exchange with the hot glycol regenerated in glycol heat exchangers E303A / B. It is then sent to the D301 oil separator where it is free of entrained natural gas and the condensate is separated from the glycol. The separation pressure is maintained at 4 bars using a pressure regulator (PIC 301).

The glycol from the oil separator goes to one of the glycol filters (S302 A/B), each filter is designed to remove particles of size equal to or greater than 5 $\mu$ m. The withdrawal then goes to the carbon filter (S303), this filter will remove some of the dissolved hydrocarbons as well as some fine particles that had not been removed by the previous filters.

The rich glycol is then heated by the lean, hot glycol in the heat exchanger (E302) or it is preheated to 85 ° C to feed the column (C301), the liquid phase flows towards the bottom where there is the re-boiler (H301) to be heated to a sufficient temperature  $T = 122$  ° C in order to eliminate the maximum amount of water absorbed and obtain an 80% glycol solution in weight.

The vapors produced at the top of the distillation column go to the condenser of reflux (E301), or they are cooled to 100 ° C and condensed in the accumulator (D302). A rich glycol bunkering is used to cool the reflux to 65 ° C before it is returned to the upper plate of the distillation column using regenerator reflux pumps (P302 A / B).

## *Chapter II: Working Principle of the MPP03.*

### • **Glycol recovery points**

There are 06 recovery points at the ability level (balloon)

- D102: high pressure final separator.
- D103: medium pressure separator.
- D104: low pressure separator.
- D105: separator rich in condensate (currently deleted).
- D106: hydrocarbon / glycol separator.
- D107: reflux accumulator for column C101.

### • **Glycol losses**

- Loss by solubility in hydrocarbons
- Losses by vaporization in the gas produced
- Loss on regeneration by vaporization or entrainment in water vapor as liquid droplets
- Various losses in purging, storage and mechanical leakage operations which are not calculable but considered to be less than a few liters per day
- The piercing of the exchanger tubes (gas / gas) considerably increases the glycol losses; these losses can be minimized by flow control and concentration of MEG to be injected by proper adjustment of the installations as well as avoiding destabilization of treatment units in order to have good separation condensate / glycol.

### **II.2.5. Utilities section:**

The operation of this factory requires the implementation of utilities, it is the brain unit of the module, it provides:

- Instrument air and service air.
- Cooling water, potable water, service water, and fire water.
- Inert gas.

### **II.2.6. Gas recompression section K002**

The dry gases coming from the balloons (D104), (D105) and (D107) at a pressure of 25Kg / cm<sup>2</sup> will be tablets in the K002A / B turbo-compressor up to 72Kg / cm<sup>2</sup> to be injected into the sales gas pipeline.

### **II.2.7. Gas section and product storage**

In this section, the condensate produced is separated from the gas it contains. This section is for purpose of transferring or storing the condensate produced in each train in two units of degassing: condensate (Off spec) and condensate (On spec).

The module contains two T001A / B storage bins for on and off condensate storage SPEC, currently the condensate produced is shipped directly to CSTF through the pumps P002A / B / C.

LPG is stored and / or shipped to CSTF. The LPG buffer tank D005 receives the LPG. The liquid is then sucked by the pumps of the LPG pipeline P004 A / B / C pushing it towards CSTF.

The "off-spec" LPG is stored in the T002 sphere, and then pressurized by the pumps of over-compression of LPG P003, to later flow to column C102.

In the event of an increase in pressure in the T002 sphere, the LPG vapors are compressed by the GPL holding K001, the latter is a piston-type compressor its rotation is ensured by an electric motor, it allows the compression of vapors up to 7 bars then cooled by the E001 dry cooler to condense; the liquid LPG is then collected in the balloon D007 then sent to the sphere.

### **II.2.8. De-propanization section:**

The de-propanization unit is designed to have propane products and commercial butane, but currently only butane is marketed.

Product specification:

C3:= 0.504                      RVP = 11.5-19.3 bar at 50 °C

C4:=0.568                      RVP = 6.9 bars at 50 ° C.

### **II.2.9. Fuel gas:**

The function of this section is to prepare and supply the fuel gas intended for module installations.

The fuel gas supply is made from 03 sources:

- Fuel gas from the K101 turbo expander of each train.
- Fuel gas from the "sales gas" shipping gas.
- Gas pipe leaving separator D105.

The fuel gas pressure is adjusted as required:

- High pressure 28 Kg / Cm<sup>2</sup>
- Medium pressure 14 Kg / Cm<sup>2</sup>
- Low pressure 04 Kg / Cm<sup>2</sup>

These gases are distributed at various points in each section.

### **II.2.10. Torch section**

For the safety of the equipment of the module, a torch system is installed which has for function to receive the excess gases released in the event of anomalies.

The torch section is made up of several torch systems:

- High pressure torch.
- Low pressure torch.
- Very low pressure torch.
- LPG torch

Each train is equipped with a high pressure torch system to ensure the operation of each train separately.

### **II.2.11. Analysis section (laboratory)**

The laboratory controls the quality of production by means of analysis of intermediate flows and finished products (dry gas, condensate, LPG)

These analyzes are carried out for:

- Guarantee the conformity of products to commercial specifications
- Detect process operating anomalies
- Optimize the operation of facilities

### **II.2.12. Electricity section**

The power supply is provided by the two lines of SONEGAS. The voltage is 30KV and the frequency of 50Hz. The voltage is reduced to 5.5KV. Three substations receive it and in turn serve the entire module. The K403 turbo-generator is able to provide a regular supply of current. It can deliver power up to 6 Megawatts at full load.

### **II.2.13. Natural Gas treatment technique:**

There are many gas treatment processes around the world and the choice of one of them is based on the following criteria:

- Quantity of raw effluent.
- Targeted hydrocarbon recovery rate,
- Product specifications,
- Overall cost of investments.

So therefore for the field of HASSI R'MEL two processes are implemented:

## *Chapter II: Working Principle of the MPP03.*

The free water contained in the load is removed by settling at the level of the first tanks separation and this after cooling through air coolers. Saturation water of hydrocarbons is removed by absorption in glycol.

The hydrated glycol having absorbed the water contained in the hydrocarbons is regenerated by distillation in appropriate units and then recycled back into the circuit. Glycol prevents also the formation of hydrates in the low temperature sections.

- **Extraction of liquid hydrocarbons**

It is done by a gradual lowering of the temperature of the raw gas, according to the processes cited, thus obtaining a very dry gas meeting commercial specifications.

- **Stabilization and fractionation**

This section of the chain allows the treatment of liquid hydrocarbons extracted from the effluent, in two phases and by distillation.

- **Stabilization**

It eliminates all light gases such as methane and ethane entrained by the liquid hydrocarbons during the various separations in the balloons.

- **Fractionation**

It consists of separating liquid hydrocarbons stabilized into condensate and LPG.

- **Medium pressure gas recompression**

The gases from medium pressure separators have the same qualities as the dry gas produced, for this they are recovered and then decompressed before being mixed with dry gas. Their recovery makes it possible to avoid gas flaring.

### **II.2.14. Gas reinjection techniques:**

#### **1. Goal of re-injections:**

The recovery of liquid hydrocarbons is limited due to condensation in the tank level and allows to:

- Reduce this condensation by maintaining pressure.

## *Chapter II: Working Principle of the MPP03.*

- Maximize the extraction of liquid hydrocarbons by sweeping wet gases.
- Produce an optimal condensate and LPG potential without having to flare excess gas, resulting in greater flexibility in the operation of the gas treatment.

### **2. Principle of re-injections:**

In order to be able to re-inject the dry gas into the reservoir, it must be brought to a sufficient pressure and this can overcome the natural pressure of the gas well. Therefore compressing it to 350 bars is required. This energy transfer is carried out by centrifugal compressors rotating at a speed of 10,000 rpm, and driven by gas turbines with a unit power of 33,500 hp.

This compression is carried out in two stages:

- Compression of dry gas to 150 bars, by low pressure compressors with cooling through air coolers and separation in balloons for possible recovery of liquids.
- Gas compression to 350 bars by high pressure compressors with final cooling through air coolers before it is routed to injection wells.

### **II.3. Organization of MPP3**

#### **II.3.1. XP department**

This is the main service that ensures the smooth running (24 hours a day) of work.

Its mission is:

- The operation of a production, re-injection, storage and shipping unit hydrocarbons according to the objectives set.
- Application of personnel and facility safety instructions.
- Development of daily, monthly and annual production reports, shipping and re-injections.
- Respect of the quality of finished products.
- Optimization of the operation of the facilities.



## *Chapter II: Working Principle of the MPP03.*

- Control and approval of shutdown and start-up procedures.
- Preparing the unit before handing it over to maintenance for servicing or inspection in accordance with safety standards.
- Study of operating problems and proposal of solutions.
- The supervision of any special operation at the service level... etc.

### **II.3.2. Maintenance and Instrumentation Department**

The maintenance and upkeep of the equipment is carried out according to a good periodic program precise, as well as a daily checklist for all equipments.

The maintenance department is made up of four essential sections:

- Methods section.
- Electricity section.
- Instrumentation section.
- Mechanical section.

### **II.3.3. Security service**

This is the service that ensures the safety of the staff and equipment of the module (prevention and intervention).

### **II.4. Description of the MPP3 gas treatment process**

Raw gas from BOOSTING arrives at the diffuser (D001) at a pressure of around 100bars and a temperature of 60°C, and then it left on three identical trains of the same capacity of 20million sm<sup>3</sup>/day.

After the diffuser, the raw gas is cooled in the E101 dry cooler to 40 ° C, the gas cooled passes to the D101 inlet separator where gas separates from water and hydrocarbons liquids, water goes to SPI, hot condensate goes to D105.

The gas from the D101 passes through the gas / gas heat exchangers E102 and

## *Chapter II: Working Principle of the MPP03.*

E103 where it cools down to  $-6^{\circ}\text{C}$ , the gas passes through the JOULE THOMPSON valve where it undergoes a first isenthalpic expansion to 99 bars at a temperature of  $-15^{\circ}\text{C}$  before arriving to the high pressure separator D102.

To prevent the formation of hydrates which may clog the exchangers, the glycol is injected into the level of exchangers E102 and E103.

The gas, the MEG solution and the liquid condensate are again separated in the D102 flask.

Having absorbed water, the MEG solution is sent under pressure to the regeneration unit.

The gas coming from the D102 will undergo an isentropic expansion in the Turbo-expander K101 which has for function of recovering the energy that occurs when a high pressure gas passes through the turbine to reduce its pressure to  $65\text{ kg / cm}^2$  and a temperature of  $(-35^{\circ}\text{C})$  before passing by the cold separator D103.

The gas cooled from the D103 passes through the gas / gas exchanger E102 on the shell side to cool the raw gas, and heats itself up to a temperature of  $43^{\circ}\text{C}$  then it is compressed to 72bars at compressor K101 and directed to the sales gas pipeline.

The part of the module formed by the heat exchangers: E102AB / CD / EF, E103AB; valve JOULE THOMPSON, the D102AB high pressure balloon; the balloon D103; the turbo-expander represents the high pressure section.

The liquid from the D101 inlet separator is sent to the condensate separator rich D105, 32 bars and  $32^{\circ}\text{C}$ .

After being preheated in the feed exchanger of the E104 Deethanizer; this feeds the lower part of the Deethanizer C101 as (hot feed), the liquidso f D102 and D103 are combined in the low pressure separator D104, the liquid of the latter passes through a reflux exchanger of the E106 Deethanizer then it supplies the 5<sup>th</sup>plateau of Deethanizer (cold feed).

The overhead gases from C101 are partially condensed in exchanger E106, the part condensate is returned to the head of C101 as reflux. The heating of the liquid being in the lower part of C101 takes place in the re-boiler H101.

The C101 supplies the debutanizer C102 by a charge consisting of LPG and condensate.

Part of the recovered LPG is used as reflux and the other part is sent to CSTF.

Chapter II: Working Principle of the MPP03.

The condensate passes through the E104 exchanger before being sent to the degassing system at through the condensate cooler E107 then it is sent to CSTF.

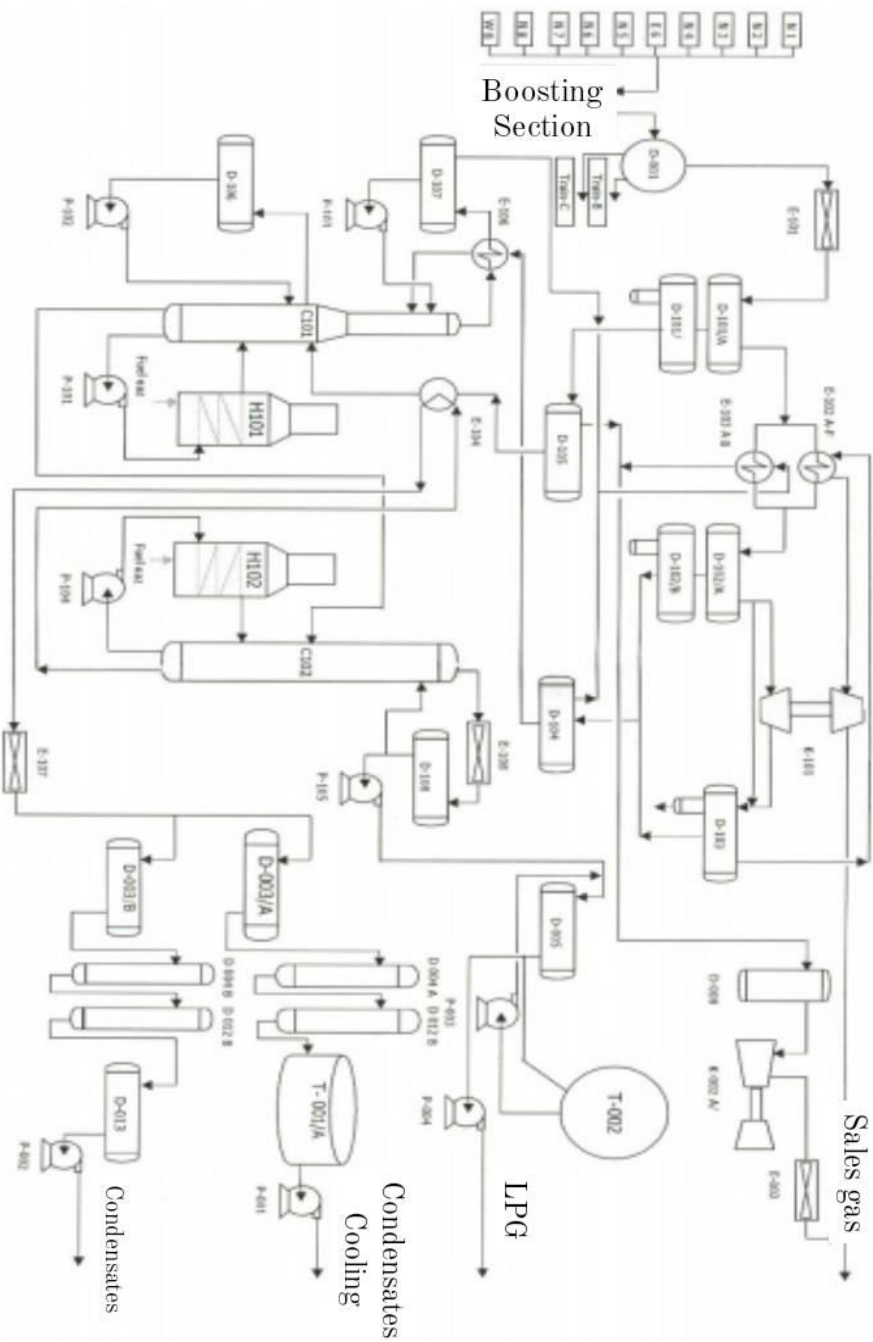

Figure.2.1 MPP3 Process Scheme [4]

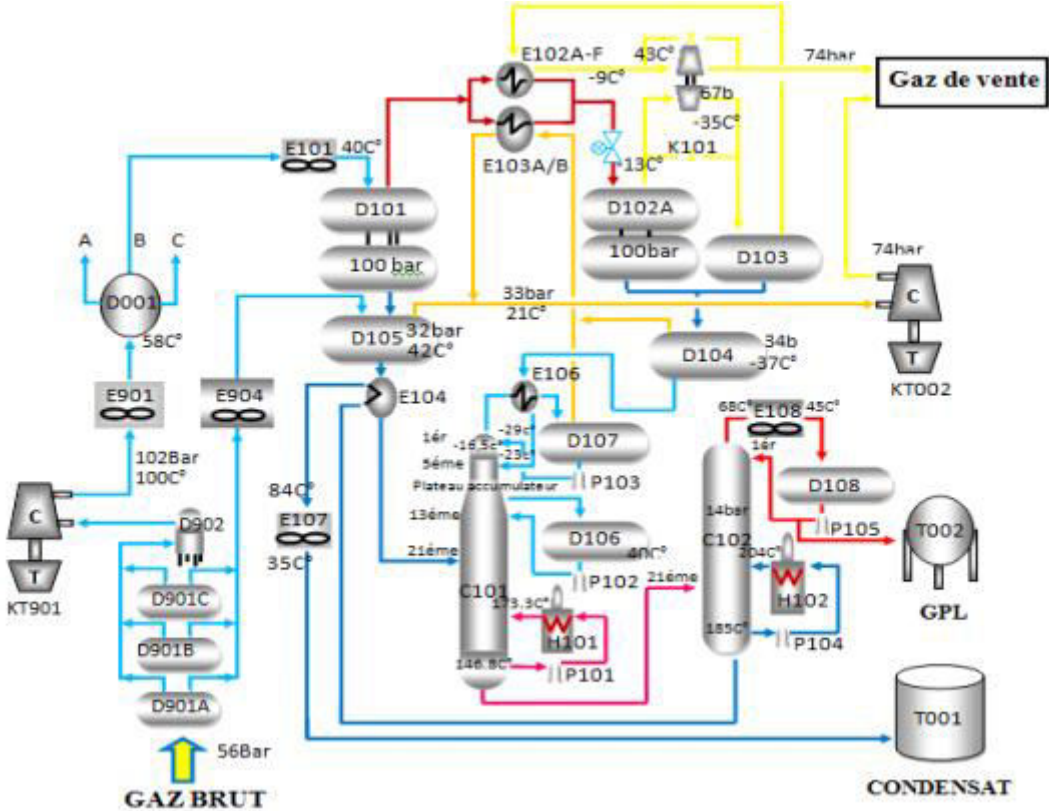

Figure2.2 MPP3 Process Scheme [4]

**CHAPTER III:  
EXPLOITATION AND  
RESULTS**

**III. Introduction:**

In this chapter we will be treating the energetic study of the plant, starting from the boosting section Gas Turbines, Deethanizer oven, H801 oven, the boilers, heat exchangers and finally the SG gas turbines.

As for the turbines, we will conduct a thermodynamic study to determine their efficiency as well as the influence of the ambient temperature on their performance.

The ovens and the boilers will be subject of a study to determine and find their efficiency and consumption, also the emissions.

When it comes to heat exchangers, and from the DCS inlet and outlet temperatures of the fluids we can calculate the effectiveness of each heat exchanger.

**III.1. Energetic study of the module and the different sectors:**

Evaluation of the energy management system the analysis is carried out at two levels of detail, which consists of drawing up the energetic study of the complex as well as that of the different production sectors. The breakdown of the complex into sectors highlights the following areas: For energy supply to meet its needs, the module is supplied with fuel gas from the pipeline transporting the sales gas to CNDG.

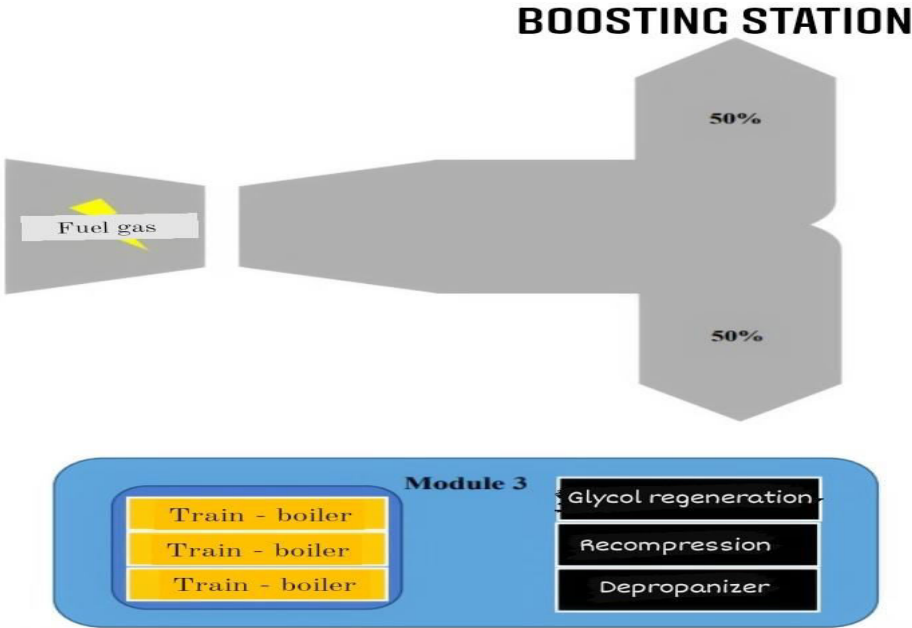

**Figure3.1 Energy diagram of the module [4]**

### *Chapter III: Exploitation and Results.*

Without fuel gas metering at the level of each energy-consuming piece of equipment, there is no such thing as an energy management system.

**Installing meters with totalizers by sector is a minimum to be able to follow the evolution of the energy situation of the complex.**

#### **III.1.1. The main energy consuming equipment in the Complex**

- 04 Turbocharger: Gas turbine GE/MES5002C + Nuovo Pignone BCL606- 3/A compressor.
- 02 Turbocharger: Gas turbine GE/MES3002J + NuovoPignone BCL 605 compressor.
- 06 ovens (two for each train) + 01 for the production of Butane.
- 02 Glycol regeneration boilers.
- 13 Torches.

#### **III.2. The MS 5002 C turbine (BOOSTING)**

##### **III.2.1. Characteristics of the MS 5002 C turbine (BOOSTING)**



### Chapter III: Exploitation and Results.

The following table gives the operating parameters of the MS 5002 C turbine given by the manufacturer under ISO conditions:

Operating Parameters Under ISO conditions	
T <sub>3max</sub>	927°C
T <sub>4max</sub>	525°C
operating power	26100 KW
energy efficiency	12493 KJ/KWh
excess air E	300 – 500 %
compression rate P2/P1	6 – 8
air flow rate at 15°C	438000 Kg/h
cooling air flow rate	12000 Kg/h
Fuel flow rate	7200 Kg/h
PCI	10835 Kcal/Kg
density of fuel gas	$\rho = 0,89 \text{ Kg/m}^3$
Molecular weight	PM=20 Kg/Kmol
combustion chamber efficiency	98%
axial compressor efficiency	88%
total turbine efficiency	29%
expansion efficiency	90%
$\alpha$ of air	1,4

**Table.1.3 Operating parameters of the MS5002 C turbine [5]**

The direct report of the influence of the ambient temperature on the global thermal efficiency of the GT MS 5002C.

Reminder on the simple and open cycle turbines Gas turbine, theoretical cycle of BRAYTON, and this to show thermally that the efficiency increases considerably with the decrease of the ambient temperature and the increase of the compression ratio of the axial compressor of the gas turbine;

There is the compression of the air drawn in, then the combustion chamber to increase the temperature of the air-fuel mixture, the turbine that collects the energy from the compressed



and heated gas to provide mechanical work, and finally an exhaust system that rejects the burned gases.

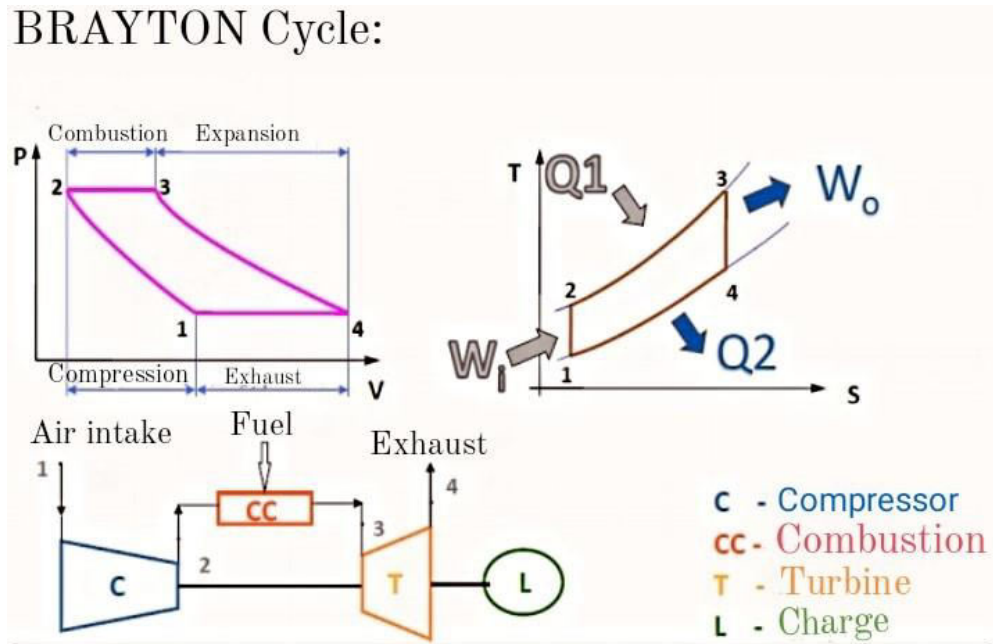

**Figure.3.2 Theoretical cycle of BRAYTON (Temperature - Entropy. S) [6]**

A gas turbine is represented by the BRAYTON diagram in a TS diagram.

- The process 1-2 represents isentropic compression.
- Process 2-3 represents isobaric combustion.
- Process 3-4 represents isentropic expansion.
- Process 1-2 represents isobaric exhaust.

We will now calculate thermodynamically the theoretical efficiency of the BRAYTON machine under I.S.O conditions (**T1= 15°C and P1= 1.013Bar**) with **T.max** which is **assumed known= T3**

The efficiency of the cycle is equal to the ratio of the useful work (turbine minus compressor) to the heat supplied to the fluid. It is therefore given by the formula:

$$W_{out} = W_{exp} - W_{comp} \dots \dots \dots [11]$$

$$\eta = (W_{exp} - W_{comp}) / Q$$

$$W_{exp} \approx h_3 - h_4 = C_p(T_3 - T_4)$$

$$W_{comp} \approx h_2 - h_1 = C_p(T_2 - T_1)$$

### Chapter III: Exploitation and Results.

$$W_{out} \approx C_p(T_3 - T_2)$$

$W_{exp}$ : the work developed by the expansion

$W_{comp}$ : the work consumed by the axial compressor

$h$ : Enthalpy

According to the first principle, on isobars  $Q = \Delta h$ , and, on adiabats,  $W = \Delta h$

$$\eta = [(h_3 - h_4) - (h_2 - h_1)] / (h_3 - h_2)$$

$$\eta = [C_p \cdot (T_3 - T_4) - C_p \cdot (T_2 - T_1)] / C_p (T_3 - T_2)$$

$$\eta = [(T_3 - T_4) - (T_2 - T_1)] / (T_3 - T_2)$$

We know  $T_1$  and  $T_3$ : ( $T_3$  is  $T_{max}$  exit combustion chamber). We must therefore recalculate  $T_2$  and  $T_4$ . To calculate  $T_2$  and  $T_4$  we know that for an isentropic evolution, we have:

$$P \cdot (T)^{\gamma / (1 - \gamma)} = C_{ste}$$

$$\text{So: } P_1 \cdot (T_1)^{\gamma / (1 - \gamma)} = P_2 \cdot (T_2)^{\gamma / (1 - \gamma)}$$

$$T_2 = T_1 \cdot (P_2 / P_1)^{(\gamma - 1) / \gamma}$$

With the hypothesis:

$$\gamma = C_p / C_v$$

For the same enthalpy:

$$P_1 = P_4$$

$$P_2 = P_3$$

This is why:

$$T_2 = T_1 (P_2 / P_1)^{(\gamma - 1) / \gamma}$$

(The unit of pressure: in Pascal)

(The unit of temperature in K ...  $T_1 = 273.16 + 15 = 288.16 \text{ K}$ )

In the same way:  $T_4 = T_3 (P_4 / P_3)^{(\gamma - 1) / \gamma}$

Chapter III: Exploitation and Results.

Knowing the different temperatures, we can therefore deduce the direct relationship with the cycle efficiency:

$$\eta = [(T3 - T4) - (T2 - T1)] / (T3 - T2) = 1 - [(T4 - T1)] / (T3 - T2)$$

$$= 1 - T1 (T4/T1 - 1) / T2 (T3/T2 - 1)$$

$$\eta = 1 - T1 / T2 = 1 - (P1/P2)^{(\gamma-1)/\gamma}$$

III.2.1. Characteristics of the MS 5002 C turbine (BOOSTING)

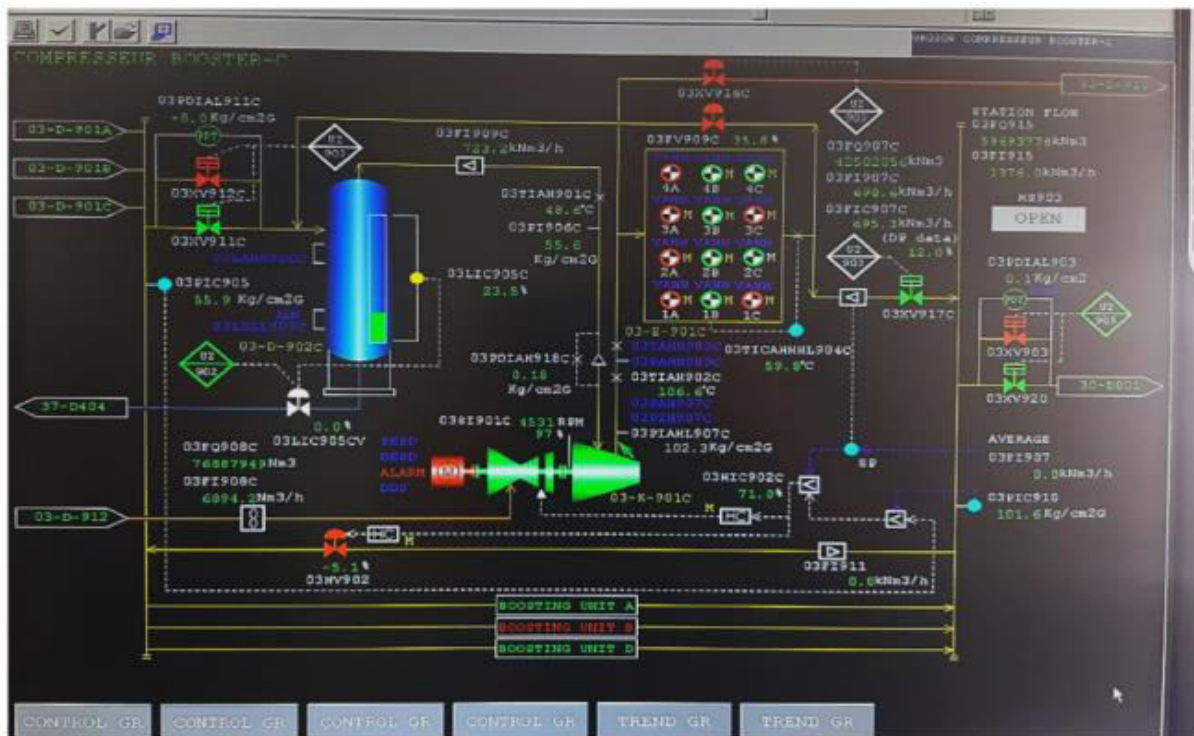

Figure.3.3 Characteristics of the MS 5002C turbine (BOOSTER) [4]

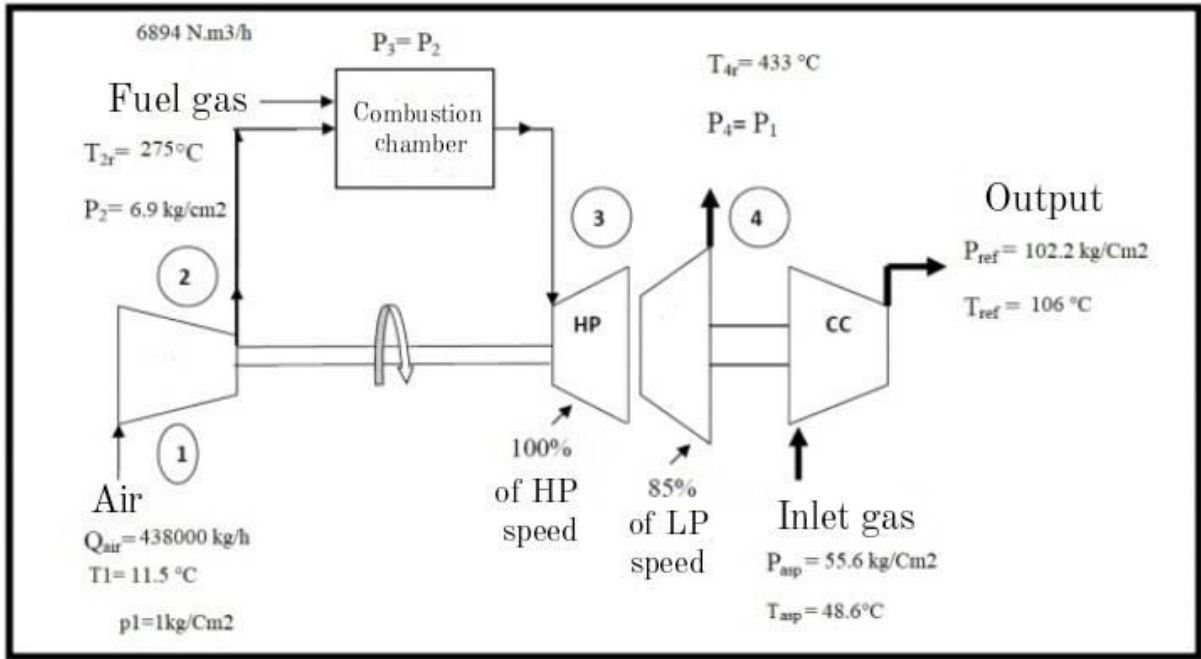

Figure.3.4 MS 5002C gas turbine (O.D) [4]

The operating conditions of MS5002C turbine for a date of 27 February 2021:

Operating conditions	Ambient temperature
Axial temperature <sub>aspcomp</sub> $T_1$	11 °C
Repression Temperature $T_{2r}$	275 °C
Exhausttemperature $T_4$	446 °C
Centrifugaltemperature suction comp	48,6 °C
Centrifugaltemperaturerefcomp	106,6 °C
Centrifugal pressure <sub>aspcomp</sub>	55,6 Kg/cm <sup>2</sup>
Centrifugal pressurerefcomp	102,2 Kg/cm <sup>2</sup>
Compression ratecurrent axial comp $\epsilon = P_2/P_1$	6,9
Combustion chamberefficiency	96
Compression drawgas flow	700 000 Nm <sup>3</sup> /h

Table. 4. Operating conditions of the MS5002C turbine [4]

**III.2.2. Energetic study of the MS 5002C Turbo Compressor (BOOSTING)**

For the two power turbines and in order to calculate the overall thermal efficiency of these two MS 5002C power turbines which are identical, we take as reference the operating parameters under ISO conditions:

Energy Efficiency (KJ/KWH), Dry Air Temperature (Ambient) C° and Relative Humidity %, and this to calculate the Thermal Efficiency which is the inverse of the Energy Efficiency given in KJ/KWh.

Calculation of the Overall Thermal Efficiency as a function of the Energy Efficiency MS 5002C:

Ambient T. = 15 °C with Design Efficiency = 12,493KJ/KWh, of which 1KWh = 3600 KJ  
 Overall Thermal Efficiency = 1/ Energy Efficiency

For the Ambient Temp. Ambient Temp. of 15 °C : Yield. Ther. Global = (3600 x 1 / 12493) x100 = 28,81%.

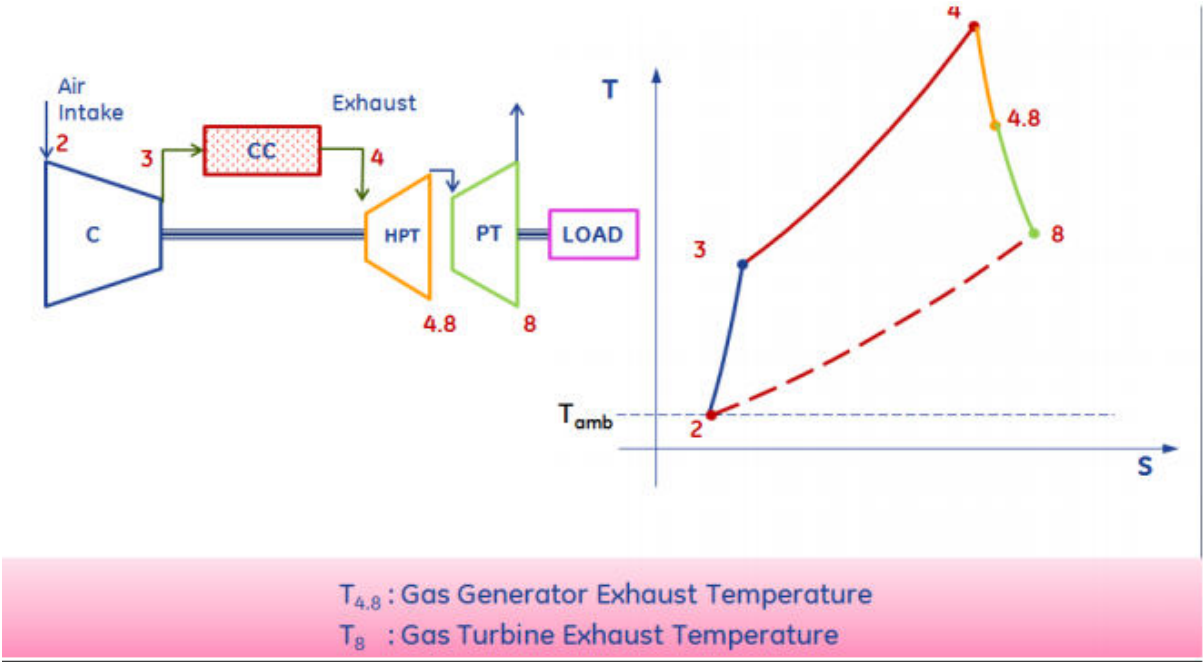

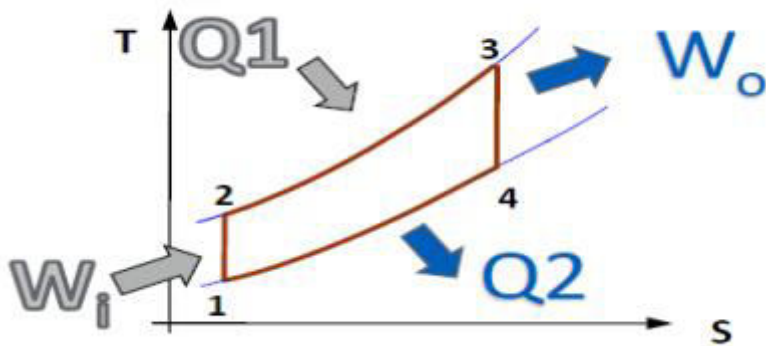

$$G.T.E = (Q_1 - Q_2) / Q_1 = 0,2881$$

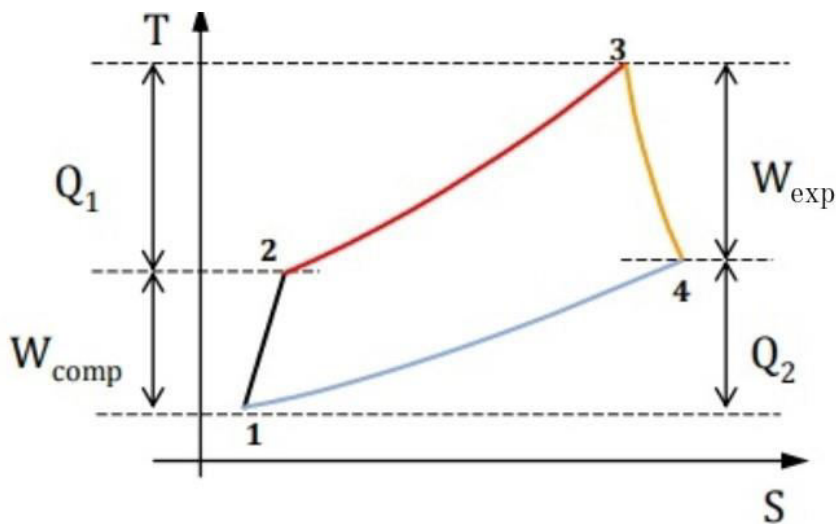

Diagrams from GE to show the thermodynamic cycle of a double shaft power turbine [7]

Energy used is defined as:

$$P_u = Q_1 - Q_2 = G_{gas} W_t - G_{air} W_c$$

$$[G_{gas} = G_{air} + G_{gas\ comb}]$$

G = Mass Flow

$$P_u = Q_1 - Q_2 = 26\ 100\ KW = 22\ 478\ 468,8995\ Kcal / H$$

So  $Q_2 = (0,711838) \times Q_1$  avec  $Q_1 - Q_2 = 26\ 100\ KW$  gives us :

$$Q_1 = 90\,574,2499 \text{ KW} = (90\,574,2499 \times 3600) / 4,18 = 78\,004\,195,0915 \text{ Kcal / H}$$

$$Q_2 = (0,71183) \times 90\,574,2499 = 64\,474,2499 \text{ KW} = 55\,528\,062,1921 \text{ Kcal / H}$$

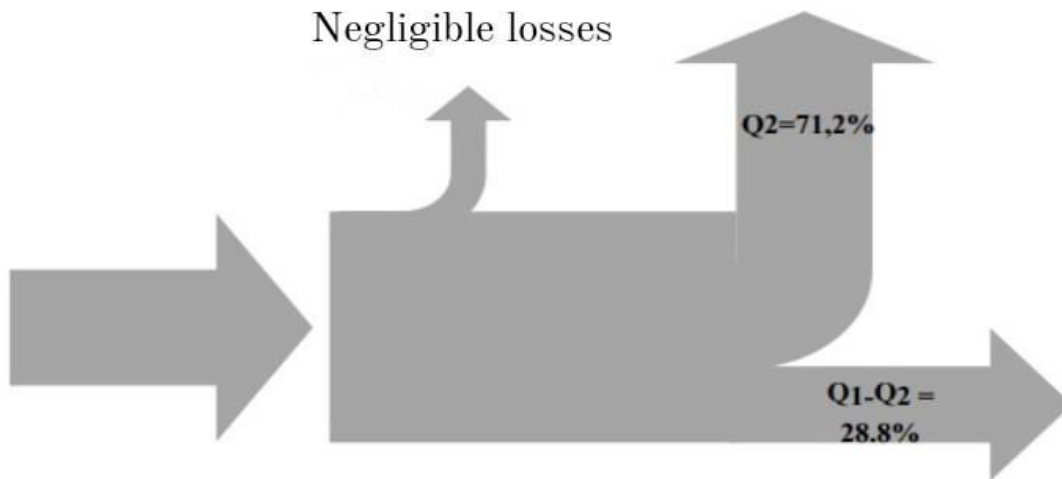

**Figure.3.5** Flow diagram of the thermal energy turbo compressor MES 5002C. [4]

The curve below shows the impact of the ambient temperature on the functional characteristics of the turbines

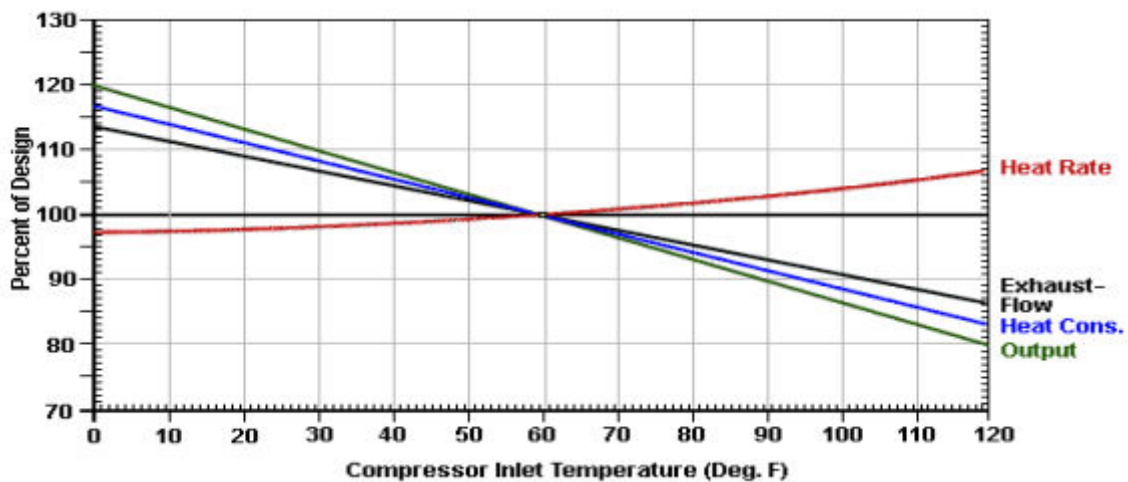

**Figure3.6: Influence of the ambient temperature on the performance of GT (Gas turbines inlets presentation GE). [8]**

1. The density of air is inversely proportional to the dry temperature
2. The output of the gas turbine depends on the mass flow rate and not on the air volume

### Chapter III: Exploitation and Results.

#### 3. Ambient temperature directly affects:

- Air flow rate
- The power
- Specific consumption
- Exhaust temperature

For open cycle gas turbines and in relation to ISO conditions, the ambient temperature has a considerable influence on the characteristics of the gas turbine within the following limits:

- AT 45 °C:
- A 22.5% decrease in power output,
- A 10% increase in specific consumption
- $P_u (15\text{ }^\circ\text{C} = 60\text{ }^\circ\text{F}) = 26\ 100 \times 1 = 26\ 100\ \text{KW} = 22\ 478\ 468, 899\ \text{Kcal / h}$
- $P_u (45\text{ }^\circ\text{C} = 113\text{ }^\circ\text{F}) = 26\ 100 \times (1-0,18) = 21\ 402\ \text{KW} = 18\ 432\ 344,497\ \text{Kcal / h}$

$$\Delta P_u = P_u (15^\circ\text{C}) - P_u (45^\circ\text{C}) = 4\ 046\ 124,401\ \text{Kcal / h} = 4\ 698\ \text{KW}$$

Therefore, the power gain of a single TG (BOOSTING MS 5002 C) during winter increases up to 4.7 MW, which allows the reflection for a feasibility study to cool the air during hot seasons.

$$P = M \times C_p \times (45-15) = 438,000 \times 0.235 \times (45-15) = 3,087,900\ \text{Kcal/h} = 3,585.395\ \text{KW}.$$



**III.3. Energetic study of the ovens (03 Trains X 02 Ovens) DEETHANIZER**



Figure.3.7 Photo taken of the ovens [4]

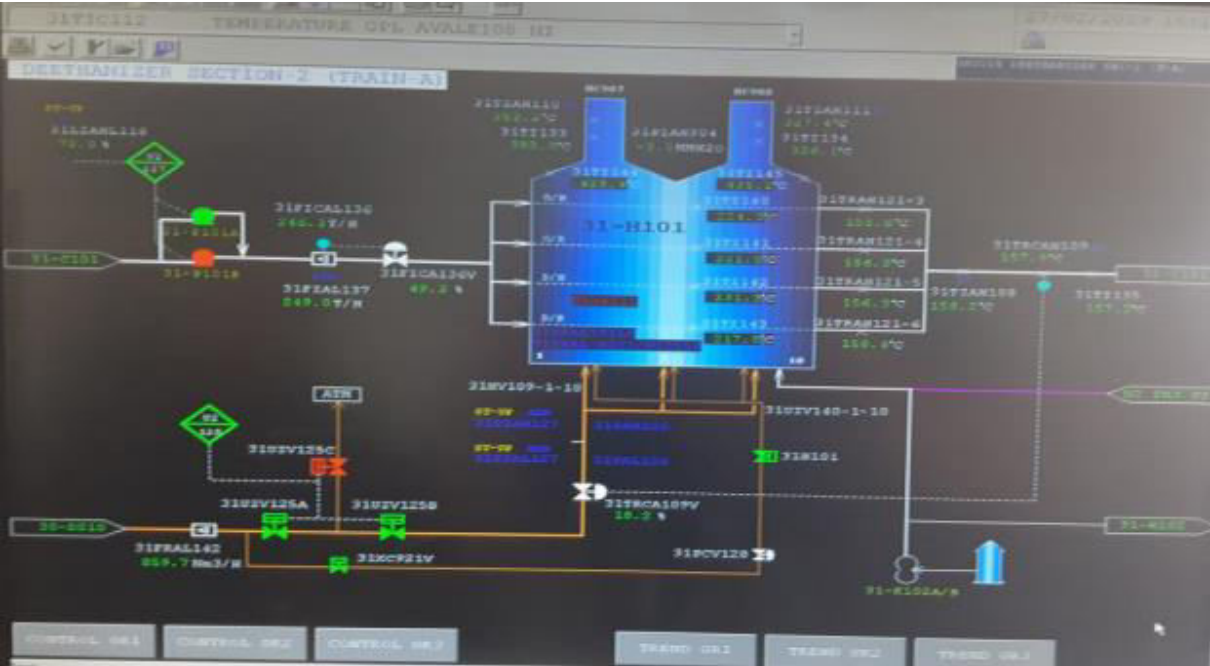

Figure.3.8 DCS diagram [4]

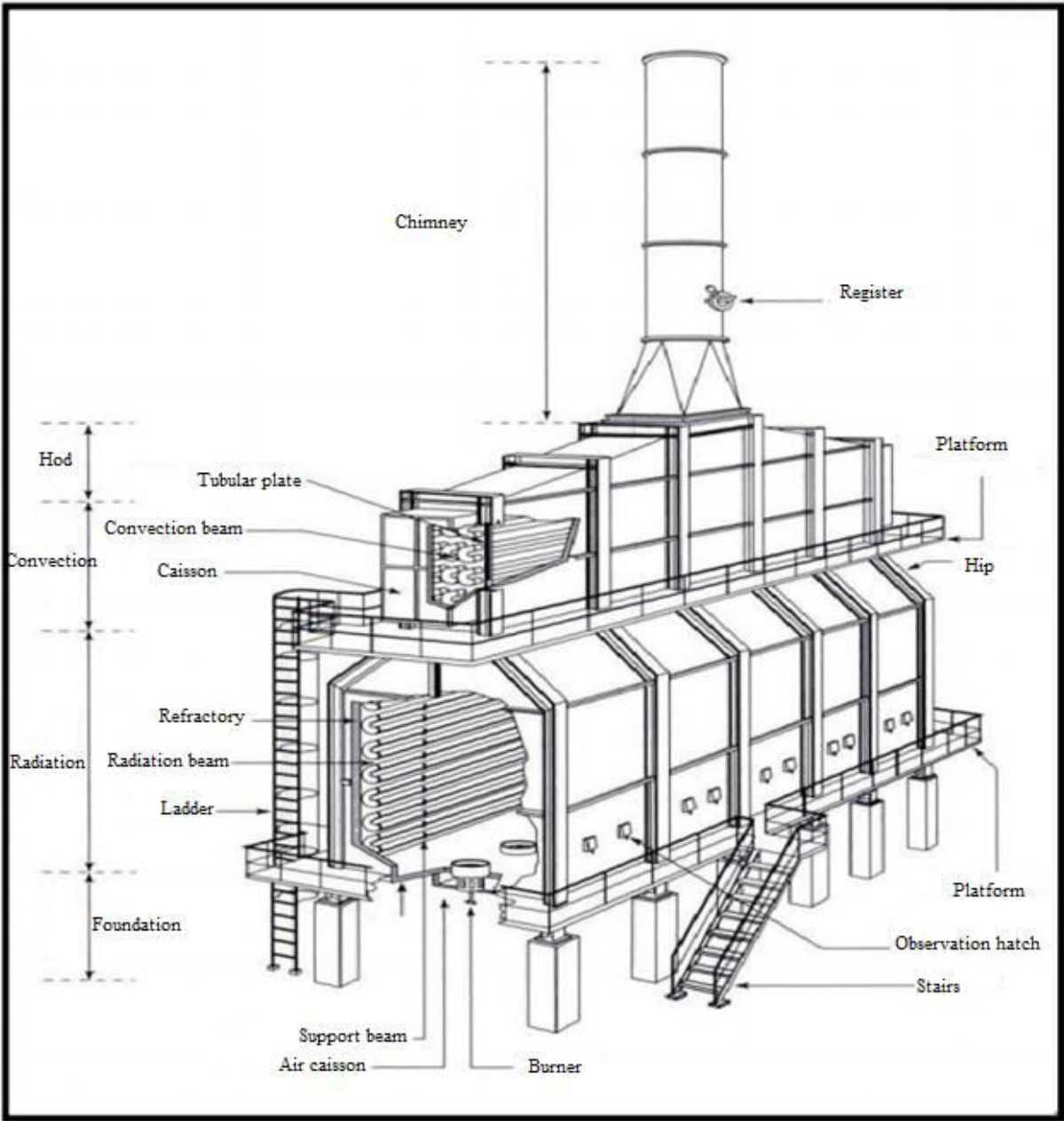

Figure.3.9 Cabin oven with horizontal tubes [4]

### Chapter III: Exploitation and Results.

The study is summarized in the determination of the specific consumption and the yield. The two phenomena to be taken into consideration in this balance are:

- The losses through the fumes which represent the important part of the heat produced
- The losses through the walls of the oven which are due to the state and quality of the thermal insulation. These losses can be important with age and lack of maintenance, otherwise they are around 2% of the heat produced.

The efficiency of an oven is the ratio between the heat absorbed by the fluid and the heat supplied by the combustion.

$$Efficiency = 100 \times \left( \frac{E_{abs}}{E_{comb}} \right) [12]$$

Where:

$$Efficiency = 100 \% - \% \text{ smoke losses} - \% \text{ wall losses}$$

These are liquid hydrocarbons that are passed through two H101 ovens:

H101: We take as example the 21-H101 seen on DCS on 27/02/2021

Flow rate  $Q = 859,7 \text{ Nm}^3/\text{h}$

#### III.3.1. Determination of the mass of oxygen O<sub>2</sub> consumed by 1 kg of fuel:

According to the combustion reaction:

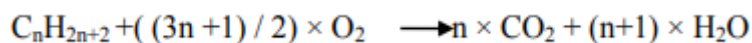

We obtain:

$$m_{O_2} = (M_{O_2} \times \frac{3n+1}{2} \times Y_i) / M_i$$

Table (3) gives the composition and heating value of the fuel gas:

Gas components	Yi'mol	Mol weight Mi (Kg/Kmol)	Mi×Yi'mol	Yi mass	LHVi (Kcal/m <sup>3</sup> )	LHVi×Yi'mol (Kcal/m <sup>3</sup> )
CH <sub>4</sub>	0,8272	16	13,2352	0,6952	8590	7105,64
C <sub>2</sub> H <sub>6</sub>	0,0851	30	2,553	0,1341	15408	1311,22
C <sub>3</sub> H <sub>8</sub>	0,0196	44	0,8624	0,0453	22284	436,76
iC <sub>4</sub> H <sub>10</sub>	0,0028	58	0,1624	0,0085	29511	82,63
nC <sub>4</sub> H <sub>10</sub>	0,0041	58	0,2378	0,0125	29643	121,53
iC <sub>5</sub> H <sub>12</sub>	0,0008	72	0,0576	0,0030	37917	30,33
nC <sub>5</sub> H <sub>12</sub>	0,0008	72	0,0576	0,0030	38049	30,44
nC <sub>6</sub> H <sub>14</sub>	0,0005	86	0,043	0,0023	46518	23,26
C <sub>7</sub> <sup>+</sup>	0,0001	100	0,010	0,0005	57896	5,79
CO <sub>2</sub>	0,003	44	0,132	0,0069	0	0
N <sub>2</sub>	0,057	28	1,596	0,0836	0	0
<b>Total</b>	<b>1</b>		<b>19,037</b>	<b>1</b>		<b>9147,6</b>

**Table.3.3 Composition and characteristics of the fuel gas**

Molecular weight of each component i: MW<sub>i</sub>

The average molecular point of the gas:  $MW_{moy} = \sum Mi \times Yi'_{mol} = 19.037kg/kmol$

Mass concentration  $\int Yi_{massic} = (Mi \times Yi'_{mol}) / \sum Mi \times Yi'_{mol} M$

$$mO_2 = \frac{(Mo_2 \times (\frac{3n+1}{2}) \times Yi)}{Mi}$$

Constituants	O2 Mass consumed by each component
CH <sub>4</sub>	2,78
C <sub>2</sub> H <sub>6</sub>	0,50
C <sub>3</sub> H <sub>8</sub>	0,164
iC <sub>4</sub> H <sub>10</sub>	0,030
nC <sub>4</sub> H <sub>10</sub>	0,093
iC <sub>5</sub> H <sub>12</sub>	0,010
nC <sub>5</sub> H <sub>12</sub>	0,010
nC <sub>6</sub> H <sub>14</sub>	0,0081
nC <sub>7</sub> <sup>+</sup>	0,00192
CO <sub>2</sub>	/
N <sub>2</sub>	/
<b>Total</b>	<b>3,597</b>

**Table.3.4 Mass of O2 required to burn 1kg of fuel for the H101 oven**

$$Q \text{ stoichiometric air} = \frac{3.597}{0.23} = 15.639 \text{ kg of air for each 1kg of fuel}$$

According to the following general chemical reaction of combustion of fuel gas C<sub>2n</sub> H<sub>2n+1</sub>:

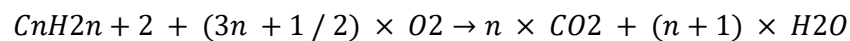

We obtain:

$$m_{O_2} = \left( m_{O_2} \times \frac{3n + 1}{2} \times Y_i \right) / M_i$$

Thus, the mass of O<sub>2</sub> consumed by each component C<sub>2n</sub>H<sub>2n+1</sub>... (Kg)

### Chapter III: Exploitation and Results.

Hence the mass of air theoretically necessary for the complete combustion of all the constituents of the gas is called stoichiometric air mass = 15,63 Kg of air for 1Kg of fuel

The ratio of air theoretically necessary for the combustion

$$Q_{\text{stoichiometric air}} = \frac{3.597}{0.23} = 15.639 \text{ kg of air for each 1kg of fuel}$$

For ordinary burners (without air pressure), in order to guarantee a complete and rich combustion, we add an excess of air estimated at  $E= 1,2$ , and this to have an excess of air compared to the stoichiometric combustion of 120%.

So,  $E=1,2$  with the flow of combustible gas of a single oven H101 that we had taken from the DCS.

$$m_{\text{Gas}} = 859,7 \text{ Nm}^3/\text{h} = 859,7 \times 1,01 \times 0,89 = 833,994 \text{ Kg/h}$$

$$1 \text{ Nm}^3 = 1,09 \text{ m}^3 \text{ and } \rho = 0,89 \text{ kg/m}^3$$

The air flow required for combustion:  $Q_{\text{exce,air}} = Q_{\text{stoichiometric}} \times E$

$$Q_{\text{excess.air}} = Q_{\text{stoichiometric}} \times E = 15,639 \times 1,2 = 18,756 \text{ kg air for 1kg of fuel}$$

Therefore, the air flow required for combustion in the H101 oven is as follows:

$$m_{\text{Air}} = 18,756 \times 833,994 = 15\,642,391 \text{ Kg/h}$$

Therefore, the mass flow rate of the fumes:

$$m_{\text{Fumes}} = m_{\text{Gas}} + m_{\text{Air}} = 16\,476,38 \text{ Kg/h}$$

$C_p$  of the flue gas  $T_{\text{moy}} = \frac{353,2+327,4}{2} = 340,3^\circ\text{C}$  according to the empirical formula below depending on the excess air  $E=1,2$  we calculate  $CP_{EG}$  of the exhaust gases with the average temperature  $T_{\text{moy}}= 340,3^\circ\text{C}$ .

$$CP_{EG} = ((0,9718 + 0,044 \div E + (0,0536 \div E + 0,0927)(T_{\text{moy}} \div 1000))) \div 4,18$$

For  $E=1,2$  we give  $CP_{GE}= 0,261 \text{ Kcal /Kg.K}$

Therefore, the energy lost with the exhaust gas as heat is:

$$\begin{aligned} Q_2 &= m_{\text{Fumes}} \times CP_{GE} \times (T_{\text{moy}} - T_{\text{amb}}) = 16476,385 \times 0,261 \times (340,3 - 11) \\ &= 1416100,80 \text{ Kcal/h} \end{aligned}$$

Chapter III: Exploitation and Results.

To have the specific heat of the air at room temperature 11°C, we have the following formula [13]:

$$Cp_{air} = (A + B \times T + C \times T^2 - D \times T^3)/29$$

$$Cp_{air} = (6,713 + (4,697 \times 10^{-4}) * T + (1,147 \times 10^{-6}) * T^2 - (4,696 \times 10^{-10} * T^3))/29$$

$$Cp_{air} = 0,04083Kcal/Kg.K \text{ At } Tamb = 11^\circ C + 273 = 284K$$

$$Cp_{EG} = 0,264Kcal/Kg.K \text{ at } Tc = (428,4 + 435,2)/2 = 431,8^\circ C = 431,8 + 273 = 704,8K$$

$$Q1 = (mG + mAir) \times CpEG \times (Tc + 273) - mAir \times Cpair \times (Tamb + 273)$$

$$= 16\,476,385 \times 0,264 \times (504,6 + 273) - 15\,642,391 \times 284$$

$$= 3\,382\,377,761 - 181\,384,786 = 3\,200\,992,975Kcal/h$$

Thus:

$$G.T.E = 1 - \left(\frac{Q2}{Q1}\right) = 1 - \frac{1\,416\,100,80}{3\,200\,992,975} = 0,557 \text{ or } 55,7\%$$

III.3.2. Energetic study of the H801 oven:

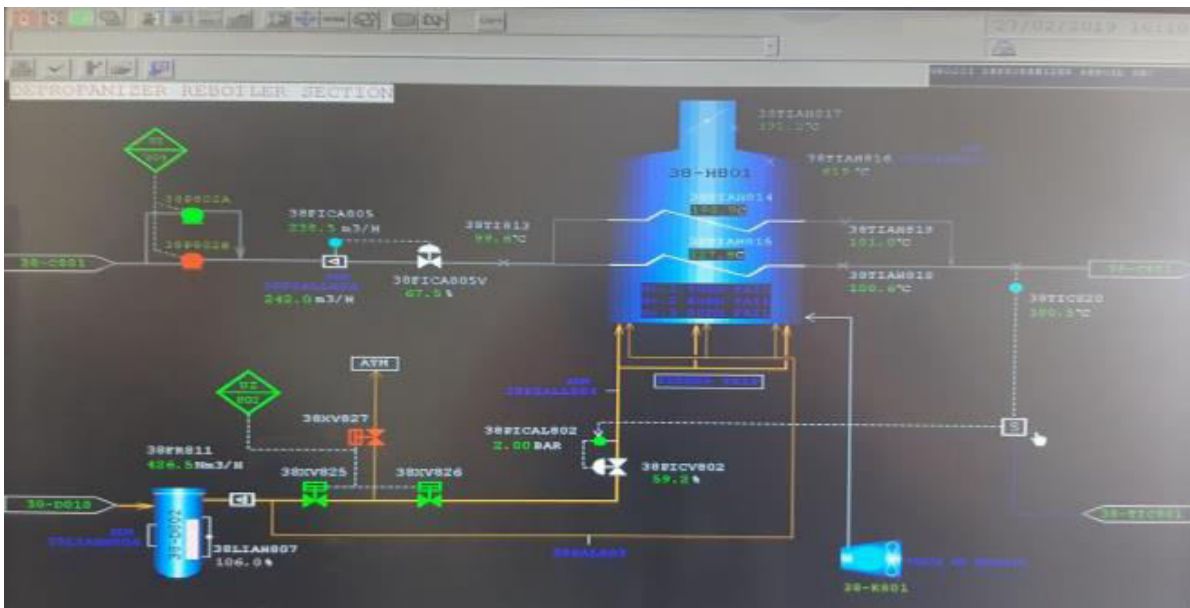

Figure.3.10 DCS diagram with operating parameters

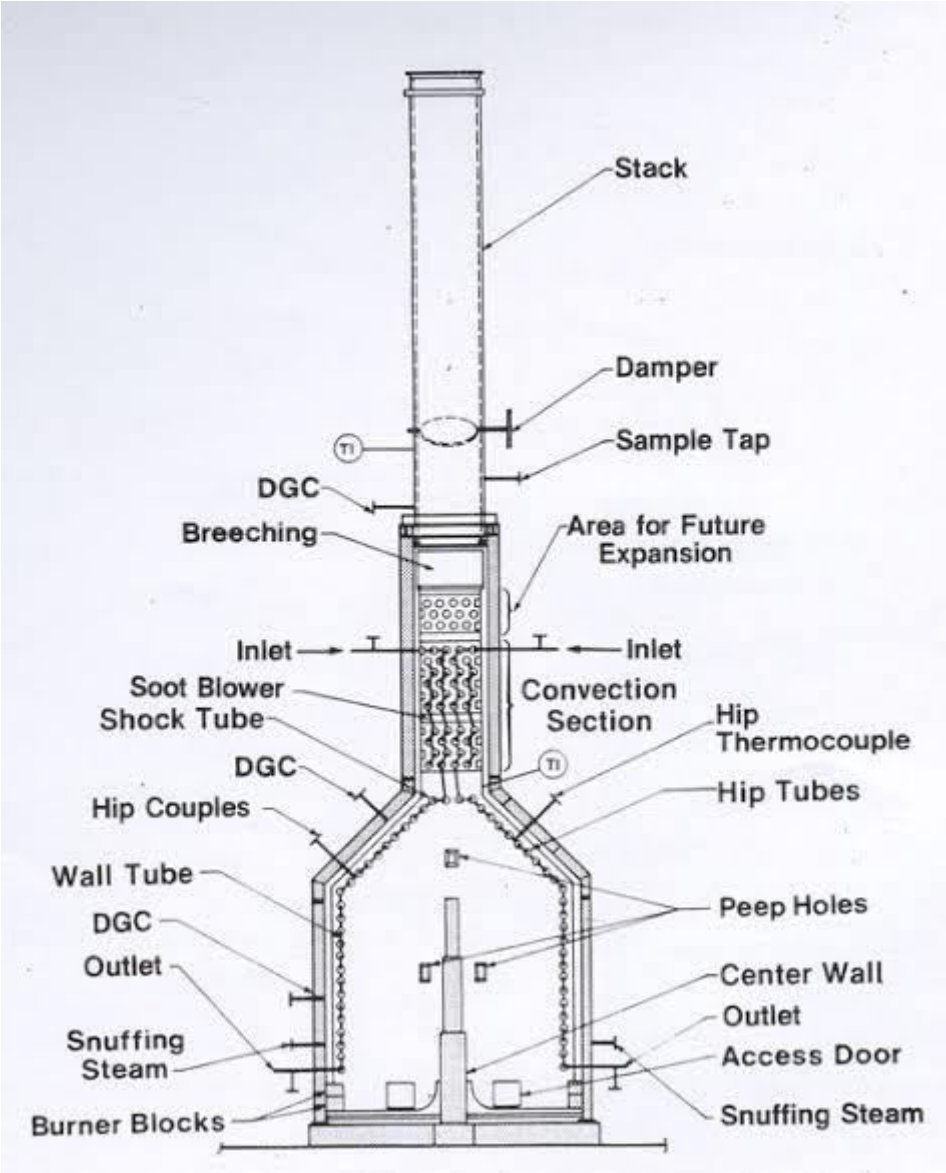

Figure.3.11 Cylindrical oven [1]



### Chapter III: Exploitation and Results.

With the same calculations and the same excess of area  $E=1,2$ , we find that the ratio of air theoretically necessary for combustion :  $Q_{\text{air stoichiometric}} = 3,597 / 0,23 = 15,639 \text{Kg d'air} / 1 \text{Kg of fuel}$

For ordinary burners (without pressurized air supply), in order to guarantee a complete and rich combustion, we add an excess of air estimated at  $E= 1,2$ , to have an excess of air compared to the stoichiometric combustion of 120%.

So,  $E=1.2$  with the fuel gas flow of a single H801 oven that we had taken from DCS.

$$m_{\text{Gas}} = 426,5 \text{Nm}^3/\text{h} = 426,5 \times 1,09 \times 0,89 = 413,747 \text{Kg/h}$$
$$1 \text{Nm}^3 = 1,09 \text{m}^3 \text{ and } \rho = 0,89 \text{kg/m}^3$$

The air flow required for combustion:  $Q_{\text{excess.air}} = Q_{\text{stoichiometric}} \times E$

$$Q_{\text{excess.air}} = Q_{\text{stoichiometric}} \times E = 15,63 \times 1,2 = 18,756 \text{ kg for 1Kg of fuel}$$

Therefore, the air flow required for combustion in the H108 oven is as follows:

$$m_{\text{Air}} = 18,756 \times 413,747 = 7\,760,238 \text{Kg/h}$$

Therefore, the mass flow rate of the fumes is:  $m_{\text{Smoke}} = m_{\text{Gas}} + m_{\text{Air}} = 413,747 + 7\,760,238 = 8\,173,986 \text{Kg/h}$

The  $C_p$  of the flue gas ( $T_{\text{moy.}} = 395,2^\circ\text{C}$  according to this formula and depending on the excess air  $E=1,2$  we calculate  $CP_{EG}$  of the exhaust gas with the average temperature  $T_f = 395,20^\circ\text{C}$ . [III-4].

$$CP_{EG} = \left( \left( 0,9718 + \frac{0,044}{E} + \left( \frac{0,0536}{E} + 0,0927 \right) \left( \frac{T_f}{1000} \right) \right) \right) / 4,18$$

$E=1,2$ . Gives us  $CP_{EG} = 0,263 \text{ Kcal /Kg.K}$

So, the energy lost with the smoke in the form of heat is:

$$Q_2 = m_{\text{EG}} \times C_{pEG} \times (T_f - T_{\text{amb}}) = 8\,173,986 \times 0,263 \times (395,2 - 11)$$
$$= 825\,937,1843 \text{Kcal/h}$$

To have the specific heat of the air at room temperature  $11^\circ\text{C}$ , we have the following formula:

$$C_{p \text{ air}} = (A + B \times T + C \times T^2 - D \times T^3) / 29$$

Chapter III: Exploitation and Results.

$$Cp. air = (6,716 + (4,697 \times 10^{-4}) * T + (1,147 \times 10^{-6}) * T^2 - (4,696 \times 10^{-10}) * T^3)/29$$

$$Cp. air = 0,04083 kcal/Kg.K \text{ at } Tamb = 11^\circ C + 273 = 284K$$

$$Cp. EG = 0,270 kcal/Kg.K \text{ at } Tc = 619^\circ C = 619 + 273 = 892K$$

$$Q1 = (m. Gas + m. Air) \times Cp. Eg \times (Tc + 273) - m. air \times Cp. Air \times (Tamb + 273)$$

$$= 8\,173,989 \times 0,270 \times (619 + 273) - 7\,760,238 \times 0,04083 \times (11 + 273)$$

$$= 1\,968\,622,880 - 89\,916,429 = 2\,978\,703,45 kcal/h$$

$$G.T.E = 1 - \left(\frac{Q2}{Q1}\right) = 1 - \frac{825\,937,1843}{1\,878\,703,45} = 0,56 \text{ or } 56\%$$

### III.4. Energetic study of the boilers

#### III.4.1. Glycol storage and injection section

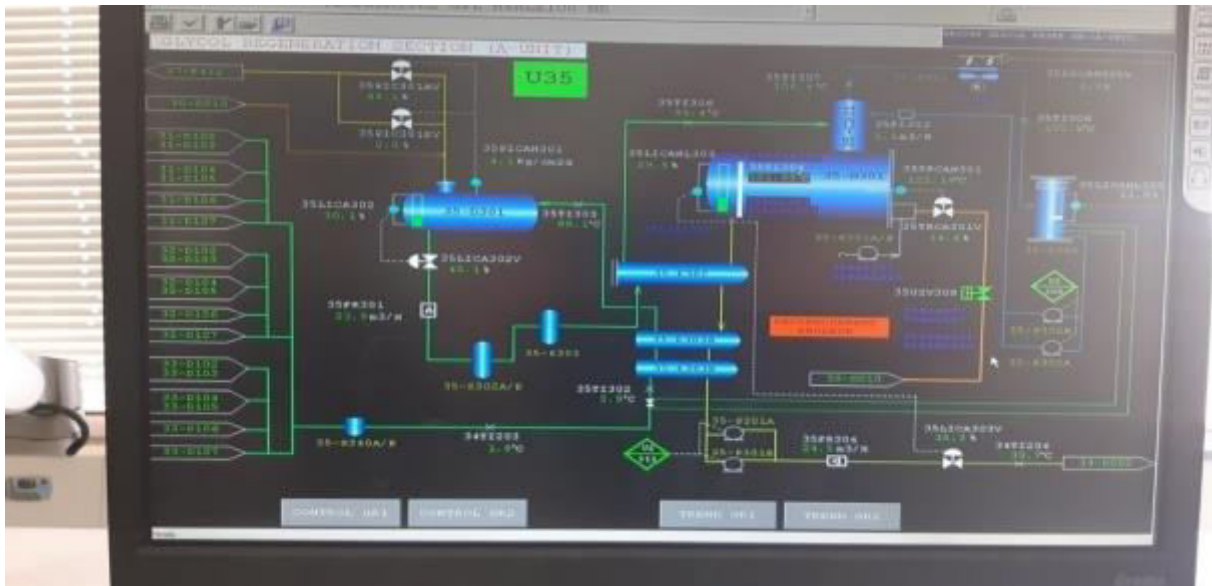

Figure.3.12 DCS...H301 diagram

The ratio of air theoretically required to burn the same fuel gas is:

$$Q \text{ air stoichiometric} = 3,597 / 0,23 = 15,639 \text{ Kg of air/1Kg of fuel}$$

$$Q \text{ air stoichiometric} = 3,597 / 0,23 = 15,63 \text{ Kg of air/1Kg of fuel}$$

For ordinary burners (without pressurized air supply), in order to guarantee a complete and rich combustion, we add an excess of air estimated at  $E = 1,2$ , to have an excess of air compared to the stoichiometric combustion of 120%.

### Chapter III: Exploitation and Results.

So,  $E=1,2$  with the flow of combustible gas in the boiler that we had taken from Module 3.

$$m_{Gas} = 268 \text{Sm}^3/\text{h} = 268 \times 0,89 = 238,52 \text{Kg/h}$$

And  $\rho = 0.89 \text{ kg/m}^3$

The air flow required for combustion:  $Q_{\text{excess,air}} = Q_{\text{stoichiometric}} \times E$

$$Q_{\text{excess,air}} = Q_{\text{stoichiometric}} \times E = 15,63 \times 1,2 = 18,756 \text{ Kg air for 1kg fuel}$$

Therefore, the air flow required for combustion with the three burners of the H301 boiler is as follows:

$$\dot{m}_{\text{Air}} = 18,756 \times 238,52 = 4\,473,68 \text{ Kg/h}$$

Therefore, the mass flow of smoke  $\dot{m}_{\text{smoke}} = \dot{m}_{\text{Gas}} + \dot{m}_{\text{Air}} = 238,52 + 4473,68 = 4\,712,2 \text{Kg/h}$

The  $C_p$  of the exhaust gases (At  $T_{\text{moy}} = 300^\circ\text{C}$ ) according to this formula and depending on the excess air  $E=1,2$  we calculate  $C_p$  EG of the exhaust gas with the average temperature  $T_f=300^\circ\text{C}$  [14].

$$C_{p,EG} = \left( \left( 0,9718 + \frac{0,044}{E} + \left( \frac{0,0536}{E} + 0,0927 \right) * \left( \frac{T_f}{1000} \right) \right) \right) / 4,18$$

$E=1,2$ . Gives us  $C_p$  EG= 0,260 Kcal/Kg.K

So, the energy lost with the smoke in the form of heat is:

$$\begin{aligned} Q_2 &= m_{\text{Smoke}} \times C_{p,EG} \times (T_f - T_{\text{amb}}) = 4\,712,2 \times 0,26 \times (300 - 11) \\ &= 354\,074,708 \text{Kcal/h} \end{aligned}$$

To have the specific heat of the air at room temperature  $11^\circ\text{C}$ , we have the following formula [13].

$$C_{p,air} = (A + B \times T + C \times T^2 - D \times T^3) / 29$$

$$C_{p,air} = (6,716 + (4,697 \times 10 - 4) * T + (1,147 \times 10 - 6) * T^2 - (4,696 \times 10 - 10) * T^3) / 29$$

$$C_{p,air} = 0,0408 \text{Kcal/Kg.K at } T_{\text{amb}} = 11^\circ\text{C} + 273 = 284\text{K}$$

$$Cp. hot = 0,263Kcal/Kg.K \text{ at } T hot = 400^{\circ}C = 400 + 273 = 706,1K$$

$$Q1 = (m. Gas + m. Air) \times Cp. hot \times (T. hot + 273) - m. Air \times Cp. air \times (T_{amb} + 273)$$

$$= 4\,712,2 \times 0,263 \times (400 + 273) - 4\,473,68 \times 0,0408 \times (11 + 273)$$

$$= 834\,054,68 - 51\,837,42 = 782\,217,262Kcal/h$$

$$G.T.E = 1 - \left(\frac{Q2}{Q1}\right) = 1 - \left(\frac{354\,074,708}{782\,217,262}\right) = 0,54 \text{ or } 54\%$$

### III.5 HEAT EXCHANGERS OF TRAIN C (High pressure side)

The energetic study of a "countercurrent heat exchanger" is shown in the following figure:

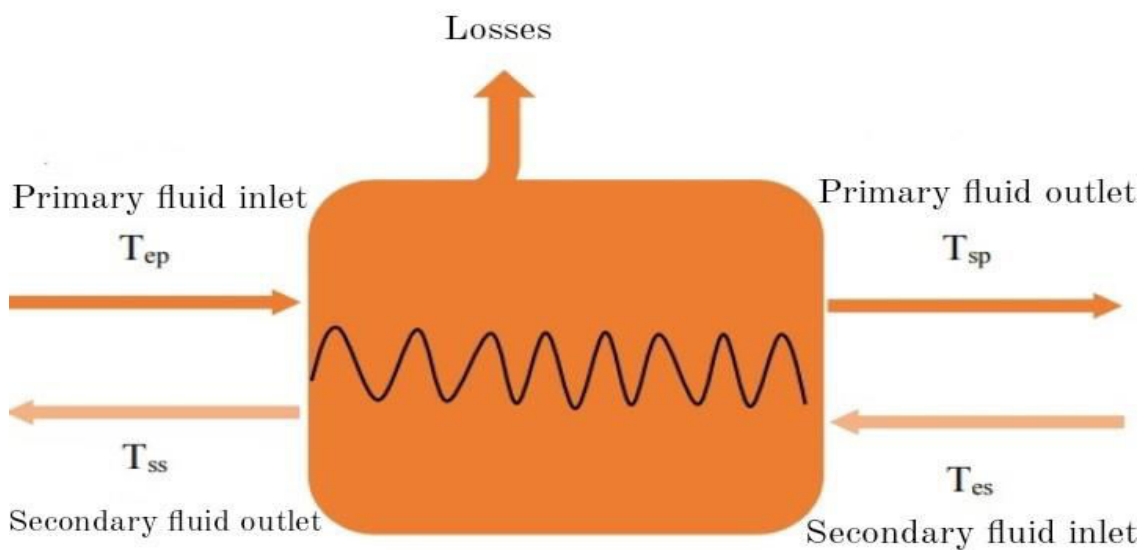

Figure.3.13 Schematic diagram of a heat exchanger [9]

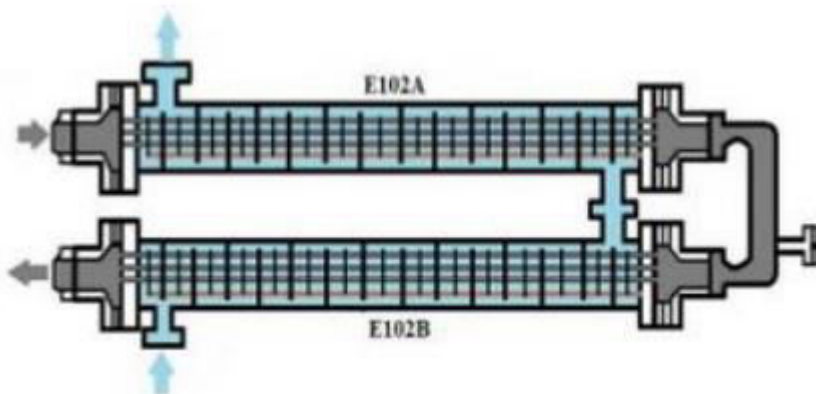

Figure.3.14 Principle of a heat exchanger [4]

### III.5.1. Temperature efficiency

If we refer to the fluid with the smallest heat flow, it is possible to calculate the effectiveness with a ratio of temperature differences.

In order to determine the efficiency of the exchangers, it is necessary to compare the exchange that it allows between the two fluids and the exchange that it would allow between them if it were perfect, i.e. :

- Without losses, thus having an exchange effectiveness equal to 1,
- Countercurrent, which is the most efficient geometrical arrangement,
- With fluids that would have different calorific flows, and with infinite surface - these are the two conditions for one fluid to exhaust the other.

PS: The E102 A/B, C/D, E/F and E103 A/B types of exchangers are very efficient in lowering the temperature to minus  $-7^{\circ}\text{C}$ , before starting the first small isenthalpic expansion at the PRCV108 valve followed by the last isentropic expansion at the expander to a temperature below  $-39^{\circ}\text{C}$ .

Also, these exchangers are insulated with insulation in order to minimize the loss of heat.

- The insulation of an industrial exchanger is never perfect; there are always heat losses to be estimated.

$$\epsilon = \frac{Q_{used}}{Q_{used\ maximum}} = \frac{Q}{Q_{max}} [16]$$

With  $\epsilon$ : Effectiveness

$$\epsilon = \frac{|\delta T| \dot{m} c_{mini}}{\Delta T_{\max \infty}} [17]$$

With  $\epsilon$ : Effectiveness

$$|\delta T| \dot{m} c_{mini} = |T_0 - T_1| \text{ or } |t_0 - t_1|$$

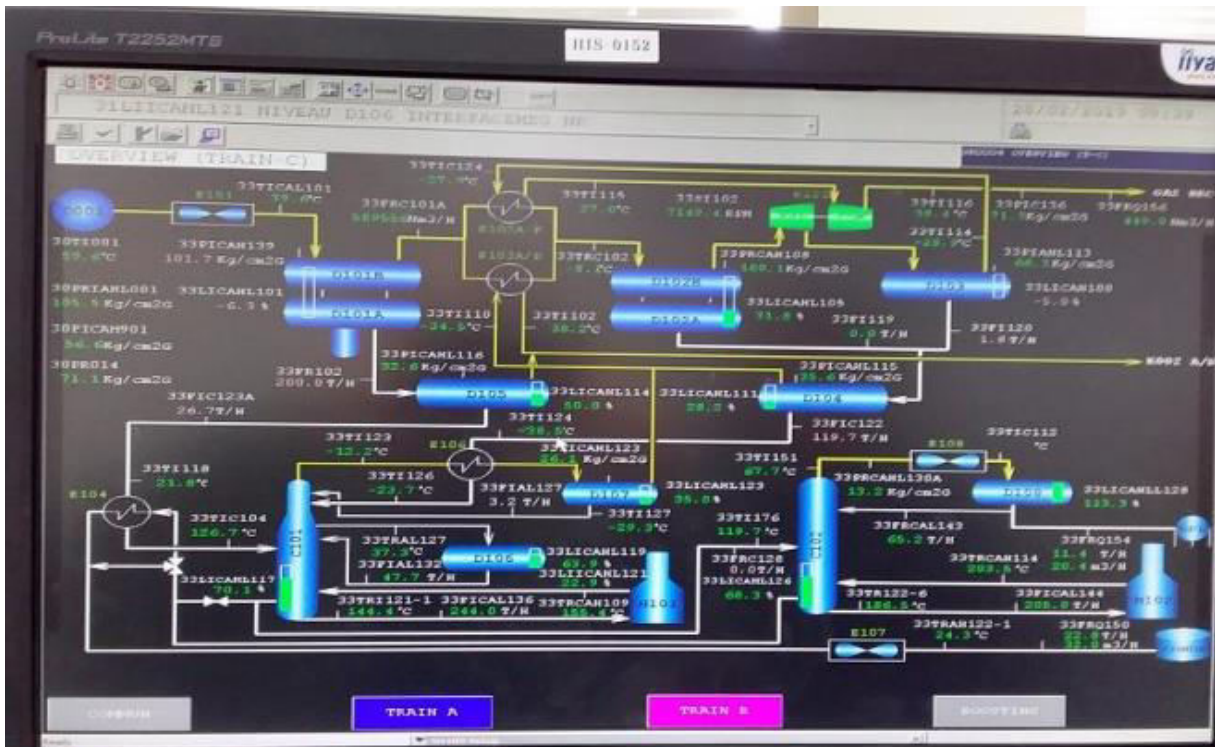

Figure.3.15 Synoptic table of the DCS in the control room (Train C) [4]



Figure.3.16 Countercurrent exchangers (high pressure part) E102  
A/B/C/D/E/F+E103A/B

**Note:** These E102 A/B/C/D/E/F counter-flow heat exchangers with E103 are well insulated with heat insulation and very efficient to avoid refrigeration loss

The results are in the following tables:

**Countercurrent exchanger (High Pressure side) E102 A/F (Train A):**

<b>Raw gas exchanger.cooler</b>	<b>Shell side (gas)</b>	<b>tube side (gas)</b>
Flow	449,09(Nm <sup>3</sup> /h) @ 71kg/cm <sup>2</sup>	589566 / 3 ( Nm <sup>3</sup> /h) @ 100kg/cm <sup>2</sup>
Inlet temperature	<b>-33°C (T<sub>E</sub>)</b>	<b>34°C ( T<sub>E</sub>)</b>
Output temperature	<b>22°C(T<sub>S</sub>)</b>	<b>-9°C( T<sub>S</sub>)</b>
E	<b>82%</b>	

**Countercurrent exchanger (high pressure part) E103 A / B:**

<b>Raw gas exchanger.cooler</b>	<b>Shell side (gas)</b>	<b>Tube side (gas)</b>
Flow	449,09(Nm <sup>3</sup> /h) @ 71kg/cm <sup>2</sup>	589566 / 3 ( Nm <sup>3</sup> /h) @ 100kg/cm <sup>2</sup>
Inlet temperature	<b>-34,5°C (T<sub>E</sub>)</b>	<b>34°C ( T<sub>E</sub>)</b>
Output temperature	<b>33°C(T<sub>S</sub>)</b>	<b>-10°C( T<sub>S</sub>)</b>
E	<b>98%</b>	

**Countercurrent exchanger (Pressure below 32 bars) E104:**

<b>Raw gas exchanger.cooler</b>	<b>shell side (liquid cond.+gpl)</b>	<b>Tube side (Gas) (liquid cond.+gpl)</b>
Flow	22,8 (T/h)	26,7(T/h)
Inlet temperature	<b>187°C (T<sub>E</sub>)</b>	<b>20°C ( T<sub>E</sub>)</b>
Output temperature	<b>65°C(T<sub>S</sub>)</b>	<b>120°C( T<sub>S</sub>)</b>
E	<b>73%</b>	

**Countercurrent exchanger (Pressure below 32 bars) E106:**

<b>Raw gas exchanger.cooler</b>	<b>shell side (liquid cond.+gpl)</b>	<b>Tube side (Gas) (liquid cond.+gpl)</b>
Flow	MIN (T/h)	26,7(T/h)
Inlet temperature	<b>-13°C (T<sub>E</sub>)</b>	<b>-43°C ( T<sub>E</sub>)</b>
Output temperature	<b>-26°C(T<sub>S</sub>)</b>	<b>-21°C( T<sub>S</sub>)</b>
E	<b>69%</b>	

**Note:** From the temperatures of the E106 exchanger, we notice that the effectiveness is around 70%

**III.6. The MS 3002J turbine of the sales gas compressor**

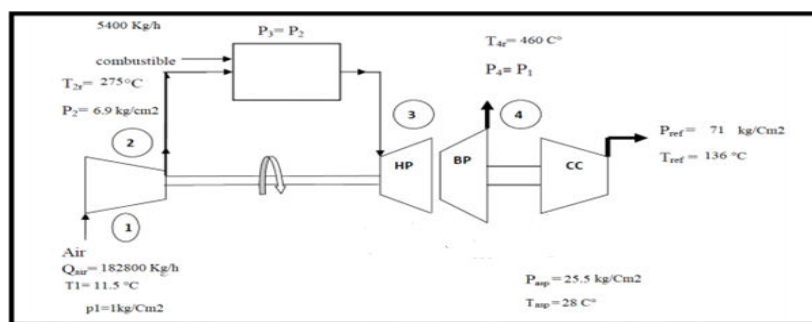

**Figure.3.17 Gas turbine MS 3002 [4]**



Chapter III: Exploitation and Results.

The following table gives the operating parameters of the MS 3002 J turbine (given by the manufacturer in ISO conditions): [4]

Operating Parameters Under iso conditions	
T <sub>3max</sub>	943 °C
Exhaust temperature	526 °C
operating power	10,9 MW
energy efficiency	13091 KJ/KWh
excess air E	300 – 500 %
compression rate P2/P1	6 – 8
air flow rate at 15°C	50,8 Kg/s × 3600 = 182280 Kg/h
cooling air flow rate	12000 Kg/h
Exhaust flow rate	52,3 Kg/s × 3600 = 188280 Kg/h
Fuel flow rate	5400 Kg/h
PCI	9512 Kcal/N m <sup>3</sup>
density of fuel gas	$\rho = 0,89 \text{ Kg/m}^3$
Molecular weight	PM=20 Kg/Kmol
combustion chamber efficiency	98%
axial compressor efficiency	87 %
Energy efficiency	13480 Kj/KWh
total turbine efficiency	26,7 %
expansion efficiency	89 %
$\alpha$ of air	1,4

**Table.3.5      Operating parameters of the MS 3002 J turbine [4]**

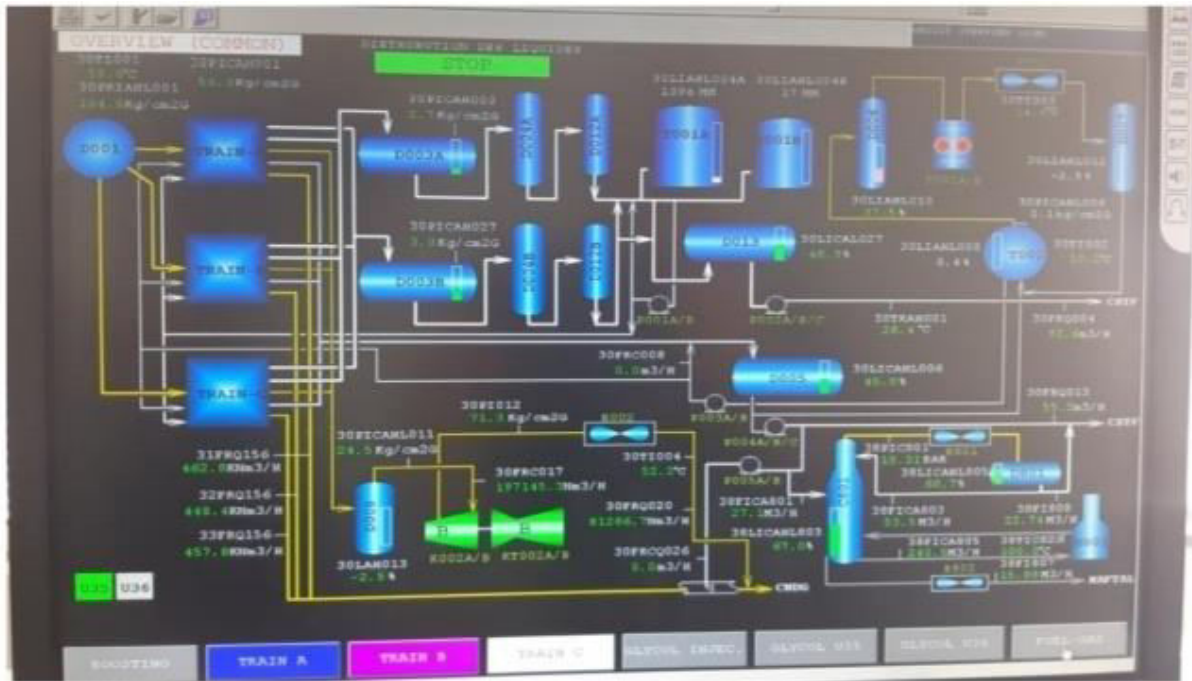

Figure.3.18 Characteristics of the MS 3002 J turbine (sales gas turbocharger)

Operating conditions of the MS 3002 J turbine

Operating conditions	Ambient temperature
Axial temperature as comp $T_1$	11 °C
Temperature ref comp $T_{2r}$	275 °C
exhaust temperature $T_4$	460 °C
Centrifugal temperature as comp	28 °C
Centrifugal temperature ref comp	136 °C
centrifugal pressure as comp	52,5 Kg/cm <sup>2</sup>
centrifugal pressure ref comp	71,3 Kg/cm <sup>2</sup>
compression rate current axial comp $\epsilon = P_2/P_1$	6,5
combustion chamber efficiency	96
compressed gas flow	700 000 Nm <sup>3</sup> /h

Table.3.6 Operating conditions of the MS 3002 J turbine [4]

### III.6.2. Energetic study of the MS 3002J Turbocharger (Sales gas):

So, for the two power turbines in order to calculate the overall thermal efficiency of these MS 3002 J power turbines which are identical, we take as a reference the operating parameters under ISO conditions:

Energy Efficiency (KJ/KWH), Dry Air Temperature (Ambient) °C and Relative Humidity %, to calculate the Thermal Efficiency which is the inverse of the Energy Efficiency given in KJ/KWh.

Calculation of the Overall Thermal Efficiency:

T. Ambient = 15 °C with Design Efficiency = 13,480KJ/KWh, where 1KWh = 3600 KJ

Overall Thermal Efficiency = 1 / Energy Efficiency

For the Ambient Temp. Ambient of 15 °C:

Yield. Ther. =  $(3600 \times 1 / 13\ 480) \times 100 = 26,70\%$ .

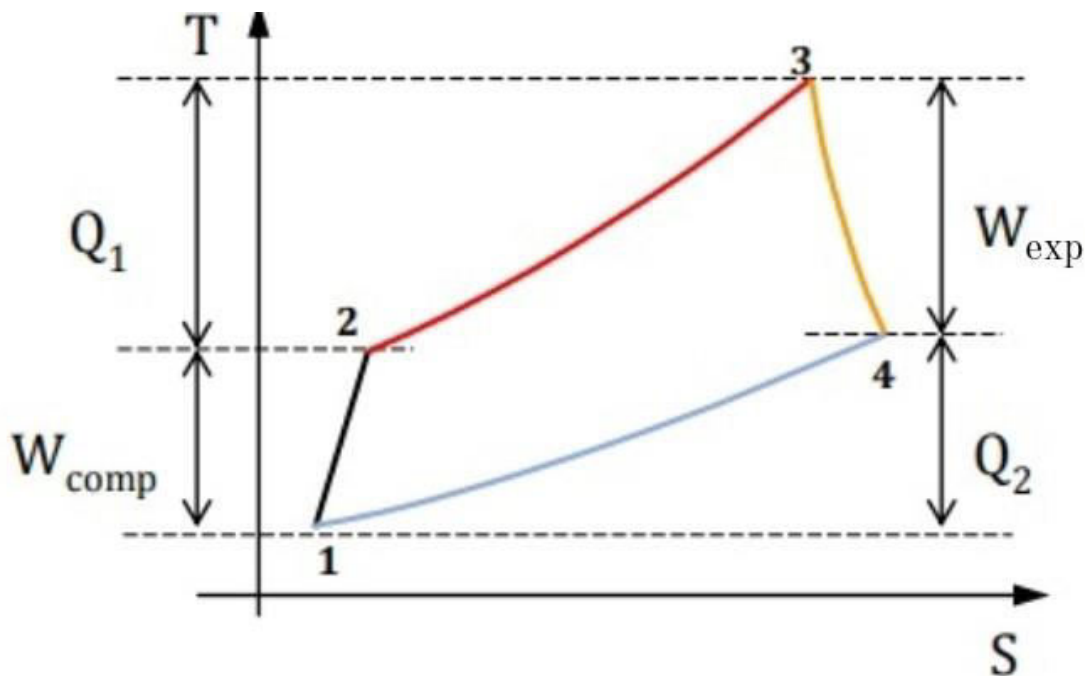
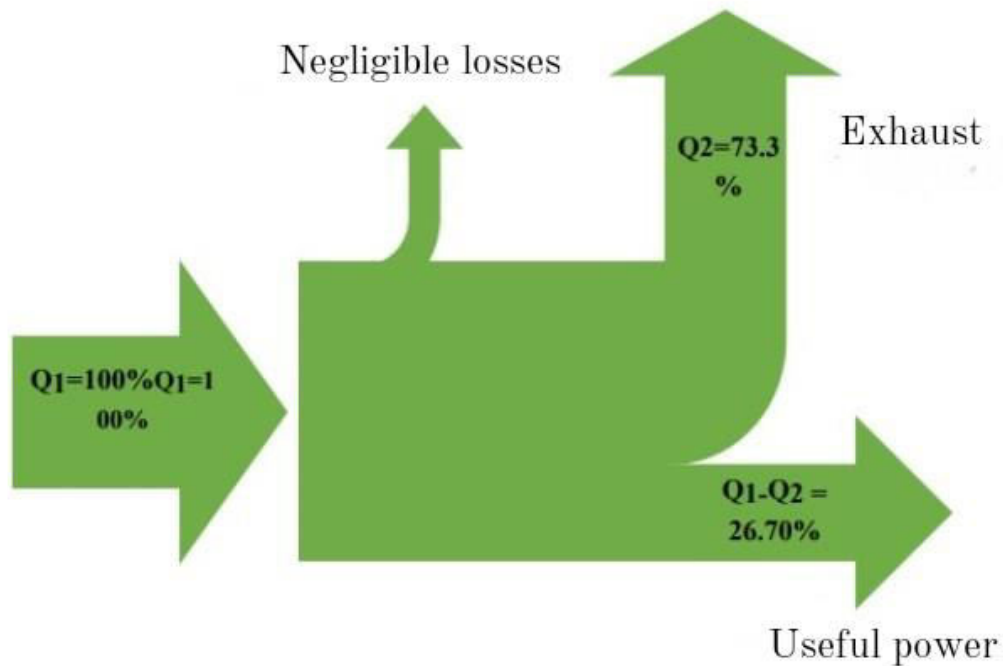

Figure3.19 Brayton Cycle [10]



**Figure.3.20 Energy flow diagram of the MS 3002J compressor (K002)**

Why neglect the losses? So much so that the losses are residual in relation to the heat quantities  $Q_1$  and  $Q_2$ , which the manufacturer has neglected them.

The energy used is defined as:

$$P_u = Q_1 - Q_2 = G_{\text{gas}}W_t - G_{\text{air}}W_c$$

$$[G_{\text{gas}} = G_{\text{air}} + G_{\text{gas comb}}]$$

$G$  = Mass flow rate

$$\text{R.T.G} = (Q_1 - Q_2) / Q_1 = 0,2670$$

$$P_u = Q_1 - Q_2 = 10\,900 \text{ KW}$$

So :  $Q_2 = (0,733) \times Q_1$  with  $Q_1 - Q_2 = 10\,900 \text{ KW}$  gives us ...

$$Q_1 = 40\,823,97 \text{ KW} = (40\,823,97 \times 3600) / 4,18 = 35\,159\,400 \text{ Kcal / H}$$

$$Q_2 = (0,733) \times 40\,823,97 = 29\,923,97 \text{ KW} = 25\,771\,840,191 \text{ Kcal / H}$$

### Influence of the ambient temperature on the power in summer MS 3002J

The curve below shows the impact of the ambient temperature on the functional characteristics of the turbines

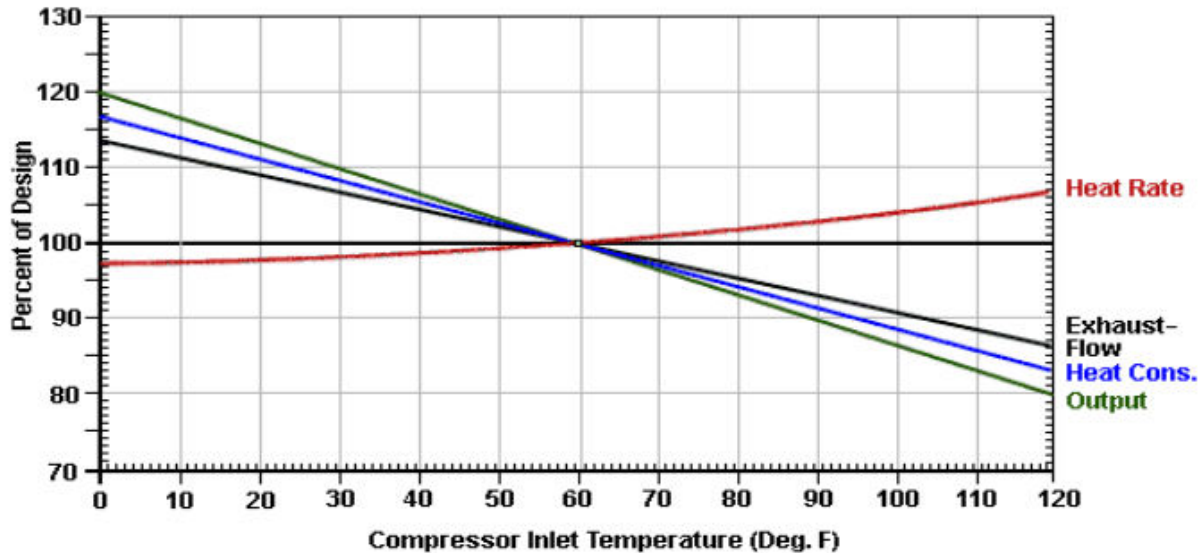

Figure.3.21 Influence of ambient temperature on the performance of GE gas turbines

1. The density of the air is inversely proportional to the temperature of the dry bulb
2. The output of the gas turbine depends on the mass flow rate and not on the air volume
3. Ambient temperature directly affects:
  - Air flow rate.
  - The power.
  - Specific consumption.
  - Exhaust temperature.

For open cycle gas turbines and in relation to ISO conditions, the ambient temperature has a considerable influence on the characteristics of the gas turbine within the following limits:

#### At 45°C:

- - An 18% decrease in power output,
- - A 5% increase in specific consumption
- $P_u (15^\circ\text{C}) = 10\,900\text{ KW} = 9\,387\,559,809\text{ Kcal / h}$

### *Chapter III: Exploitation and Results.*

$$- P_u (45^\circ\text{C}) = 10\,900 \times (1 - 0,18) = 8\,938 \text{ KW} = 7\,697\,799,043 \text{ Kcal / h}$$

$$\Delta P_u = P_u (15^\circ\text{C}) - P_u (45^\circ\text{C}) = 1\,962 \text{ KW} = 1\,689\,760,765 \text{ Kcal / h}$$

Thus, the power gain of only one out of two 1/2 TG (MS 3002J) during winter increases to 1.962MW, which allows the reflection for a feasibility study to cool the air during the warm seasons.

#### **III.7 Important solutions regarding the gas turbines, which are the thermal equipments that consume the most in the MPP03:**

Taking into account the calculation results, we have just confirmed that the decrease in turbine efficiency is directly related to the inlet air flow of the axial compressor which becomes less dense at high temperatures; studies have shown that the efficiency drops dramatically every 10°C above the ISO temperature. In our case, the efficiency of the KT-901B turbine has decreased by 18% with an increase of 23°C.

It was also found that this phenomenon of drop in efficiency affected the poly-tropic efficiency of the centrifugal compressor.

Solutions have been proposed to reduce the influence of temperature on the operation of the turbine, including:

##### **III.7.1 Injection of water vapor into the axial compressor (Wet Compression WC):**

One of the most effective methods of increasing turbine performance is to reduce the upstream work required by its axial compressor.

The axial compressor consumes about 30 to 50% of the total power of the turbine.

The injection of water mist or droplets allows the air to cool

Wet compression has the following advantages:

- Less power for the compressor
- More power for the turbine
- More efficient cycle

Wet compression is a function of: pressure ratio / Injected humidity flow / Compressor geometry.

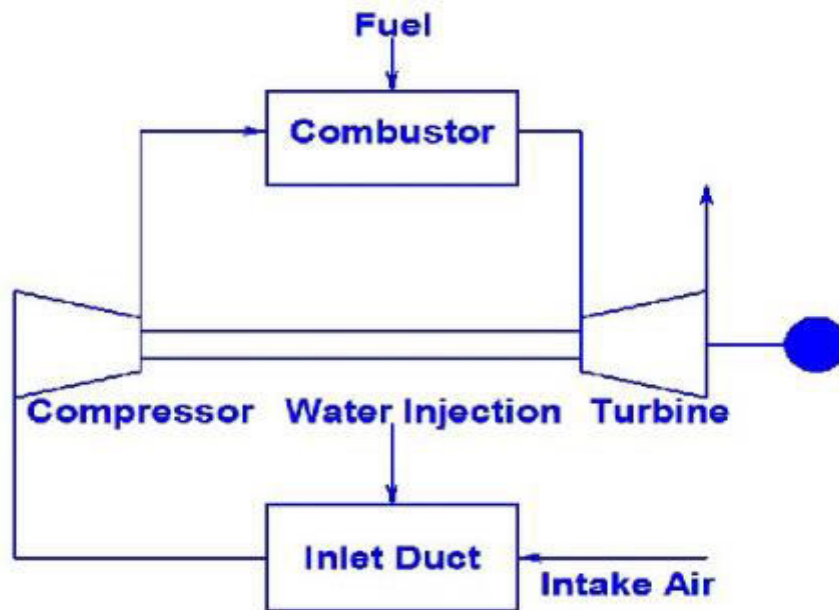

**Figure3.22: Turbine cycle with water vapor injection into the axial compressor  
(Wet compression cycle)**

### **III.7.2 Steam injected gas turbine STIG:**

In a turbine cycle with steam injection, the turbine exhaust gases are used to superheat water.

The superheated steam will be injected into the combustion chamber; or the discharge of the axial compressor; before the combustion chamber.

This technique consists of adding mass density to the combustion air without using the work of the compressor,

Its advantage is not only limited to the increase in efficiency and power generated by the turbine, it also has the advantage of controlling NO<sub>x</sub> emissions

In addition, the temperature of the chamber will be lower, which is beneficial from a technological point of view.

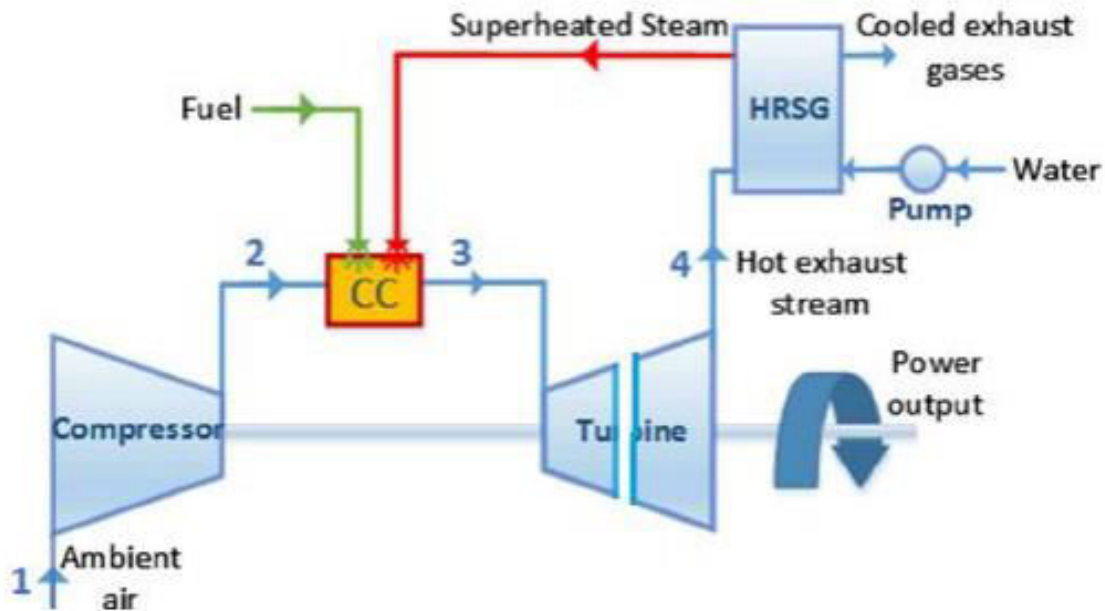

Figure3.23: Turbine cycle with the STIG System steam injection system.

### III.7.3 Combined cycle (Integrated Wet compression and STIG cycle SWC cycle):

This system has the power output advantage of the WC cycle, and the advantage of the STIG.

However, its performance is less important than that of the STIG. All the previous solutions are very widespread in the field of turbines, and very efficient (there are many others based on air cooling that we have not mentioned); however, they present some application difficulties:

- Evaporative cooling requires a very careful study in order to find the optimum quantity of water to inject while increasing the efficiency of the turbine without damaging the compressor.
- The injected water must be well demineralized and therefore the installation of a good water treatment system is essential.
- Fairly high water consumption and therefore a demand for another energy source.



Given the constraints due to the previous solutions, we strongly recommend the installation of an exhaust gas recovery system, it will perhaps be less efficient than that of evaporation but presents a rather interesting performance improvement for an installation that is less expensive.

### III.7.4 Installation of an air heater:

It consists in heating the air at the entrance to the combustion chamber, this serves to increase the temperature  $T_3$  and therefore more thermal energy in the combustion while advantageously using the heat of the exhaust gases thus it will also contribute to reduction of thermal losses.

This solution also has a major ecological advantage since  $CO_2$  and  $NO_x$  emissions are reduced considerably.

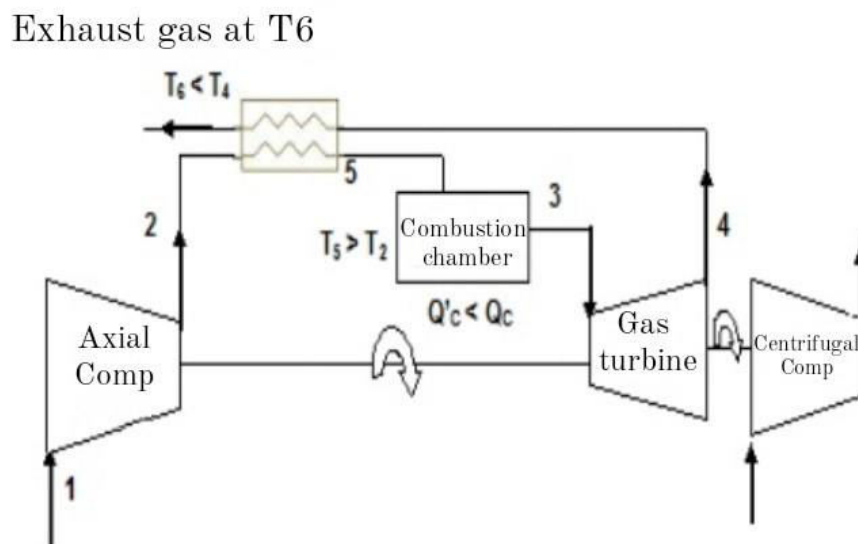
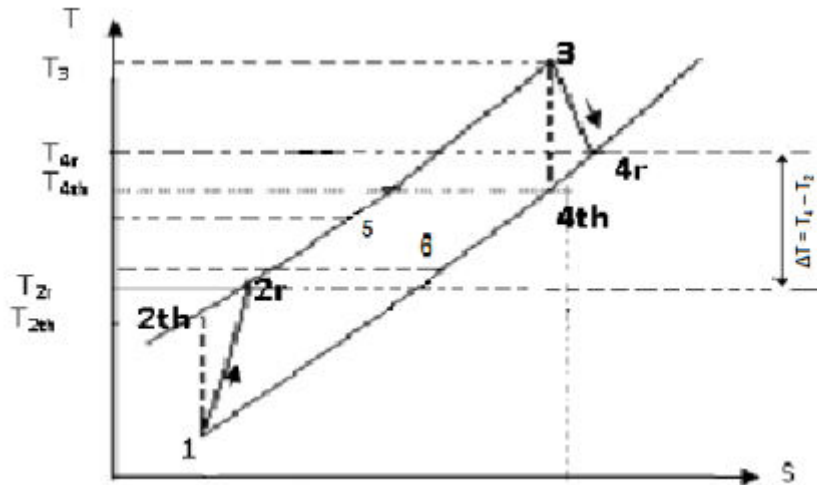

Figure3.24: Turbine cycle with a heat recovery system.



**Figure3.25: Thermodynamic cycle of the turbine with a heat recovery system.**

The cycle will therefore be as follows:

- 1 - 2: Compression.
- 2 - 5: Heating of the air in the recuperator.
- 5 - 3: Heating of the air in the combustion chamber.
- 3 - 4: Expansion in the turbine.
- 4 - 6: Cooling of the exhaust gases in the recuperator.

The yields of the recovery cycles are generally between 0.7 and 0.85 according to studies.

As we have seen from the studies performed on the heat exchanger that already exist in the MPP03, they have a really good effectiveness, and a similar heat exchanger can be installed.

The installation of such heat exchanger does not require a lot of space.

III.7.5 Calculation of the new turbine efficiency by installing the heat recovery system:

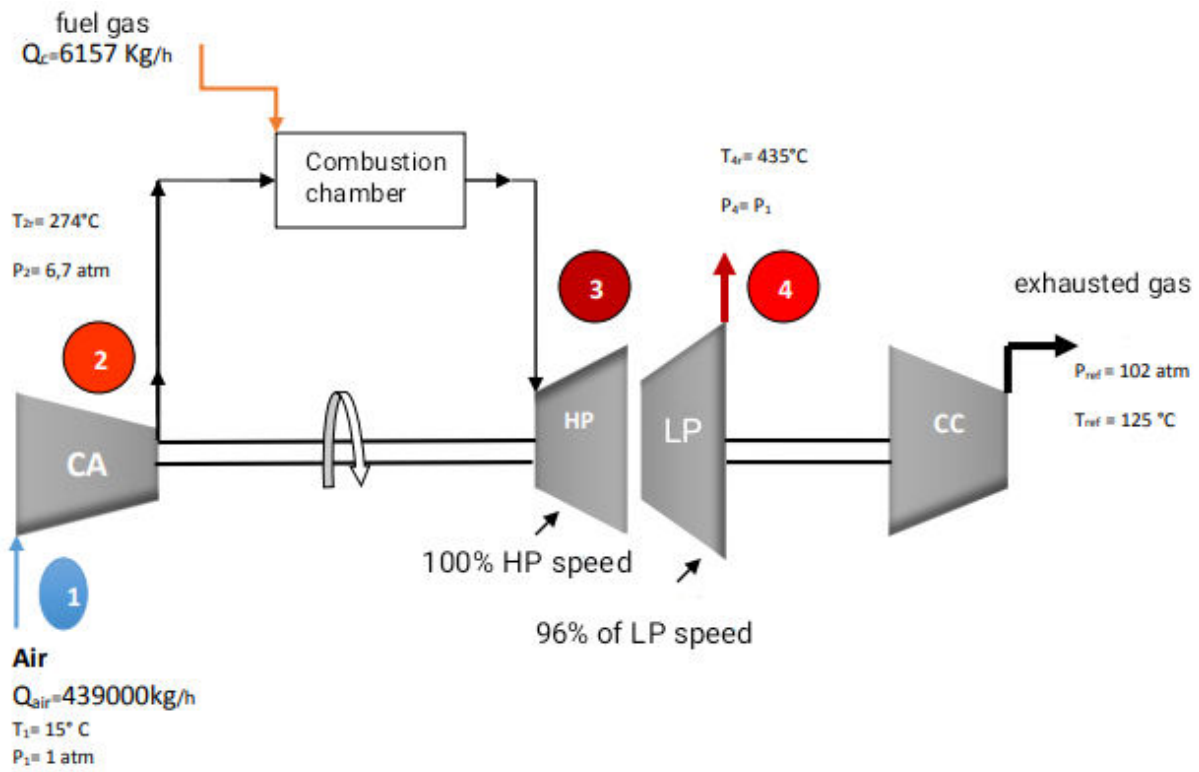

Figure.3.26 Problem data at ISO conditions given by SONATRACH [4]

Assuming an exchange yield of 0.85:

We have [18]:

$$Q_{\text{exchanged}} = Q_{\text{air}} * C_p_{\text{air}} * (T_5 - T_2) = Q_{\text{EG}} * C_p_{\text{EG}} * (T_4 - T_2)$$

$$\text{In another way: } m_{\text{air}} * C_p_{\text{air}} * (T_5 - T_2) = m_{\text{EG}} * C_p_{\text{EG}} * (T_4 - T_2)$$

For an exchanger efficiency which is assumed to be equal to  $r = 0.85$ :

$$(T_5 - T_2) / (T_4 - T_2) = 0.85$$

$$T_5 = 0.85 * (435 - 274) + 274$$

Thus  $T_5 = 410.85^\circ\text{C}$ .

We obtain from the equation:

### Chapter III: Exploitation and Results.

$$T6 = T4 - [Q_{air} * C_p \text{ air avg} * (T5 - T2) / Q_{EG} * C_p (EG T4)]$$

So we have:

$$T6 = 435 - [439\,000 * 0.2515 * (410.85 - 274) / (439\,000 + 6157) * 0.252]$$

And  $T6 = 300.41^\circ\text{C}$

- $H = C_p * T$

We also have  $H2 = 68.02$  Kcal/Kg, the mass flow rate of the fuel is  $Q_f = 6157$  Kg/h according to (Suivi richesse 2016 at a temperature of  $15^\circ\text{C}$ ),  $H3 = 212.57$  Kcal/Kg according to [17], LHV is equal to  $10726.2167$  Kcal/kg, at  $15^\circ\text{C}$ ;  $C_p \text{ air} = 0.240$  Kcal/Kg.C,  $H_{fuel}$  at  $15^\circ\text{C}$  is  $H_f = 7.35$  Kcal/Kg,  $C_p \text{ fuel gas at } 15^\circ\text{C} = 0.490$  Kcal/Kg C,  $H4 = 109.89$  Kcal/Kg.C,

#### **The new overall efficiency of the turbine after installation of the air heater:**

$$\eta_{th} = (Q1 - Q2) / Q1$$

$$Q1 = H3 * (Q_{air} + Q_f) - H2 Q_{air} = 224.96 * (439\,000 + 6157) - 0.2384 * 270 * 426\,000$$

And then  $Q1 = 63\,4431.13$  kcal/h

$$Q2 = (H6 - H1) (Q_{air} + Q_f)$$

$$H6 = C_p (T6) * T6 = 0.2495 * 300.41$$

And we have:  $H6 = 74.98$  kcal/kg

$$Q2 = (74.98 - 3.6) (439\,000 + 6157)$$

And:  $Q'2 = 31\,77\,603.8$  kcal/h

From the previous results we can calculate our new efficiency that is:

$$\eta_{th} = Q1 - Q2 / Q1 \text{ so } \eta_{th} = 50\%$$

#### **Calculation of fuel consumption with the new efficiency:**

$$H5 = C_p * T5 = 0.245 * 410.85$$

$$H5 = 105.00$$

$$Q'_f = \{PT + (H6 - H5) Q_{air}\} / ((PCI + hc) \cdot \eta C.C) - H6$$

### Chapter III: Exploitation and Results.

$$Q'f = (51621.435 + (74.98 - 105) 439000) / (10726.21 + 7.35 \cdot 0.96) - 74.98$$

So we obtain:  $Q'f = 5400.82$  Kg/h

#### Summary results after installation of a heater:

	<b>T1 = 2°C</b>	<b>T1=15°C</b>	<b>T3=38°C</b>
<b>T5 °C</b>	375,65	410,85	470,75
<b>T6 °C</b>	287,20	300,41	336,47
<b>Q'c Kg/h</b>	<b>5520,18</b>	<b>5400,82</b>	<b>5408,9</b>
<b><math>\eta'</math>%</b>	<b>49</b>	<b>50</b>	<b>49</b>

We can clearly see from the results of the benefit of this installation:

We can observe the insensitivity of the turbine to the change in temperature since the efficiency is almost stable. The efficiency of the turbine has increased by 22% which is excellent. In addition, fuel consumption has decreased a lot at 15 °C; it has dropped from 6157 Kg / h to 5400 Kg / h.

Finally, the advantageous point for the environment of this technique is the reduction of CO<sub>2</sub> emissions since the consumption of fuel gas is reduced. In addition, less NO<sub>x</sub> emissions since there is less excess air.

Now we might think that the yield of 85% of the recovery cycle is the best case scenario, what if the yield was 70%.

That would mean that our turbine would have an efficiency of 46%, 47% and 46% at T1=2°C, 15°C, 38°C respectively. Which is also excellent compared the initial efficiency without the installation of a heat recovery system, so we highly recommend the installation of such system.

Other recommendations:

- Cleaning and proper maintenance of air filters; if the filters are not properly cleaned or (the self-cleaning air intake units are not well maintained), this could cause a fairly large pressure drop and therefore a monumental loss in turbine efficiency.
- Compressor washing.

Hassi R'mel is an area known by sandstorms; compressor blades can be damaged by accumulating layers of sand or dirt, so it is advisable to wash depending on the weather in the area.

### **III.7.6 Conclusion concerning the study carried out on the turbines:**

This study revealed the following points:

- High temperature air requires more compression power due to its low density.
- Specific consumption increases with the increase in temperature.
- Raising the temperature at the exhaust reduces the power of the turbine.
- The efficiency and power of the turbine strongly depend on the air flow entering the axial compressor.
- The poly tropic efficiency of the centrifugal compressor decreases with the decrease in the power absorbed at high temperatures.
- The installation of a heater is a proven and effective technique which improves the performance of the turbine, and which contributes to the reduction of greenhouse gas emissions.

The objective of this work was to measure the deviation of the turbine efficiencies of the KT901 B machine at different temperatures to propose a solution which allows the increase in the performance of the turbine by reducing its sensitivity with the ambient temperature while improving combustion and reducing CO<sub>2</sub> emissions.

In order to develop this study and enrich it in order to put it into practice, it would be more appropriate to do a detailed technical-economic study to see its profitability.

Other practices such as heat recovery are also recommended to remedy the influence of ambient temperatures; a comparative study would also be fruitful for the choice of the ideal solution to set up for a similar project.

### III.8 Evaluation of the energy management system:

**The analysis is carried out at two levels of detail, which consists of the energy balance of the complex as well as that of the different production sectors. The breakdown of the complex into sectors shows the following areas:**

- BOOSTING Station
- MEG regeneration circuit
- Heating circuits Hydrocarbons
- Compression part of sales gas

For energy supply to meet its needs, the module is supplied with fuel gas from the pipeline carrying sales gas to CNDG. We note that half of the energy is consumed to increase the raw gas inlet pressure to the module. Special attention must be given to this part of the plant if energy consumption is to be optimized. For this report, the only thing that can be done -as long as the process requires this boosting operation-, is to take maximum advantage of the energy released by the TC Boosting.

Energy released by TC at exhaust is 55.528 MKcal/h or 55528 Therm / h

The energy lost per year and per CT is 486 M TH

For an operation of 3 CTs, we will have a total of 1,458 MTh to recover just at the Boosting module

If we add 25 772 TH/H released for the compression of the sales gas. That is 226 MTH per year; we will have a total energy gain at the module level of 1665 MTH.

The partial use of this free and permanently available energy can be used at the module level. Where gas is consumed to extract heat, direct gas combustion can be replaced by heat recovery through heat exchangers. The heat released in the boosting process can largely cover the needs of the whole module.

We list the 07 ovens and the boiler.

We will have saved the equivalent of 51 M SM3 of gas

### *Chapter III: Exploitation and Results.*

In addition to the economic advantage, the replacement of ovens and boilers by heat exchangers, there would be no more CO<sub>2</sub> emission at the level of these equipments since there will be no more combustion. Without counting combustible gas and without measuring thermal indicators at the level of each energy consuming equipment, we cannot in any case speak about energy management system.

**Installing meters with totalizers and temperature measurement points by sector is a minimum to be able to follow the evolution of the energy situation of the complex**

#### **A) Energy action plan**

##### a. Immediate Actions:

- Study of the possibility of voluntary and intermittent shutdown of a train
- Launching the procedure for the acquisition of metering equipment for energy-consuming equipment (installing meters with totalizers for each sector is a minimum requirement for monitoring the evolution of the complex's energy situation)
- Proposal -after training- of an energy man for the follow-up of the energy management

##### b. Medium and long term actions:

The tables below summarize for each recommended action the energy gains in million Therms (Mth) relative to the current energy consumption as well as the expected annual energy savings.

The accepted proposals and corrective actions will be considered by the managers in the energy efficiency improvement programs of the complex.

In addition to the improvement actions mentioned below, the managers can support the idea of an extended audit in order to map the energy consumption of the Hassi R'mel area.

#### **Besides, what will we have gained?**

- More safety at the module level since boilers and ovens will be eliminated
- Savings in the cost of operation and maintenance of boilers and ovens



Return on investment: this time will be assessed once the technical-economic study has been completed

### **III.9. IMPACT ON THE ENVIRONMENT**

Since the fuel gas consumption of the MS5002C (Booster) turbomachines in service represents more than 50% of the overall consumption of the Module, we will calculate the amount of CO<sub>2</sub> released based on the combustion reaction

#### **A) Determination of the amount of CO<sub>2</sub> emitted**

The quantities of CO<sub>2</sub> emitted to the atmosphere for 1 kg of fuel gas are determined according to the combustion reaction:

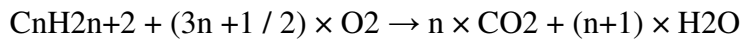

$$m_{CO_2} = (M_{CO_2} \times n \times Y_i) / M_i$$

The result obtained is detailed in the following table:

Constituant du gaz	Y <sub>i</sub> 'mol	M <sub>i</sub> (kg / kmol)	M <sub>i</sub> ×Y <sub>i</sub> '	Y <sub>i</sub> concentration massique	PCI <sub>i</sub> × Y <sub>i</sub> 'mol	n	Constituants	Masse d'CO <sub>2</sub> cons. par chaque const. (Kg)
CH <sub>4</sub>	0,8272	16	13,2352	0,698538027	7105.64	1	CH <sub>4</sub>	1,92097957
C <sub>2</sub> H <sub>6</sub>	0,0851	30	2,553	0,134744287	1311.22	2	C <sub>2</sub> H <sub>6</sub>	0,29643743
C <sub>3</sub> H <sub>8</sub>	0,0196	44	0,8624	0,045516441	436.76	3	C <sub>3</sub> H <sub>8</sub>	0,09103288
iC <sub>4</sub> H <sub>10</sub>	0,0028	58	0,1624	0,008571278	82.63	4	iC <sub>4</sub> H <sub>10</sub>	0,01625587
nC <sub>4</sub> H <sub>10</sub>	0,0041	58	0,2378	0,0125508	121.53	4	nC <sub>4</sub> H <sub>10</sub>	0,02380324
iC <sub>5</sub> H <sub>12</sub>	0,0008	72	0,0576	0,003040059		5	iC <sub>5</sub> H <sub>12</sub>	0,00557344
nC <sub>5</sub> H <sub>12</sub>	0,0008	72	0,0576	0,003040059		5	nC <sub>5</sub> H <sub>12</sub>	0,00557344
nC <sub>6</sub> H <sub>14</sub>	0,0005	86	0,043	0,002269489		6	nC <sub>6</sub> H <sub>14</sub>	0,00406397
C <sub>7</sub> <sup>+</sup>	0,0001	100	0,01	0,000527788		7	nC <sub>7</sub> <sup>+</sup>	0,00092891
CO <sub>2</sub>	0,003	44	0,13200	0,006966802		1	CO <sub>2</sub>	0,0069668
N <sub>2</sub>	0,057	28	1,59600	0,084234971		0	N <sub>2</sub>	0,06618462
Total	1,001		18,947	1			Total	2,43780018

**Table 3.7: Quantities of CO<sub>2</sub> emitted**

Molecular weight of each component: MW<sub>i</sub>

### Chapter III: Exploitation and Results.

The average molecular point of the gas:  $PM_{moy} = \sum M_i \times Y_i'_{mol} = 18,947 \text{ kg/kmol}$

Mass concentration  $Y_i = (M_i \times Y_i'_{mol}) / \sum M_i \times Y_i'_{mol}$

The table below gives the mass of O<sub>2</sub> consumed by each component:

$Y_{MolarO_2}$  in the air = 21 %, so  $Y_{mas} = (0,21 \times 32) / 29 = 0.23 \text{ Kg O}_2 / 1 \text{ Kg of air}$

$m_{CO_2 \text{ emitted}} = 2,4378 \text{ Kg of CO}_2 \text{ emitted} / 1 \text{ Kg of fuel}$

Therefore, for the fuel flow (MS 5002C):

$Q_c = 6\,687.86 \text{ Kg/h}$ , we'll have  $15\,469 \text{ kg/h}$  de CO<sub>2</sub> emitted

P.S: Since it is the same chemical composition of the Flue Gas at Module 2, we will take the cumulative fuel gas of a representative year (2016) and total the mass of CO<sub>2</sub> emitted from the exhausts of all energy consuming equipment operating at Module 2.

$m_{CO_2 \text{ emitted}} = 267\,560\,000 \times 0.89 \times 2,43 = 578\,652\,012,00 \text{ Kg}$  in the atmosphere on (2016)

For module 2, we have the fuel gas consumption (2016) equal to

$150\,004\,000 \text{ Sm}^3 = 150\,004\,000 \times 0.89 = 133\,503\,560 \text{ kg}$ .

If we deduct the consumption of the MS3002J Turbine (Designation Flow = 5400 kg/h) which is about  $5400 \times 24 \times 365 = 47,304,000 \text{ kg}$ , we can say that the six ovens and the boiler consumed in (2016):

$133\,503\,560 - 47\,304\,000 = 86\,199\,560 \text{ kg}$  of combustible gas with the amount released from the CO<sub>2</sub>

$86\,199\,560 \times 2.043 = 209\,464\,930.8 \text{ Kg}$  of CO<sub>2</sub>

**Quantity of CO<sub>2</sub> equivalent to 210 Tons**

## **CONCLUSIONS**

The energy audit that we have carried out concerns only module III. This work is carried out in accordance with a recognized audit methodology based on energy and economic gain.

If the conclusions of the feasibility study are in favor of the proposal of a heat recovery station - and this is what we expect - we will have both:

- Succeeded from the point of view of safety to protect the complex against any possible incident, especially because of the heating ovens for hydrocarbons and boilers for glycol regeneration.

- Achieved a feat from the point of view of energy and environmental efficiency by contributing to the achievement of the objectives of Algeria (2015-2030) by saving millions of cubic meters of gas and reducing as much cubic meters of CO<sub>2</sub>.

This audit could not take into account all aspects for several reasons (legal, technological and economic constraints and also those related to the operation). We think especially of:

- Energy saving aspects related to buildings and the rest of the sectors
- Innovative solutions to improve energy efficiency such as technical management software for buildings or others for the optimization of energy consumption
- Clean energies including solar thermal at the base of life (air conditioning by absorption)

It should also be noted that the heat recovery potential is enormous and far exceeds the needs targeted in our audit (the system or module).

An energy source management system larger than the module can meet this purpose.

**It is necessary to think globally about an energy mapping of the Hassi R'mel area.**

Hence, we recommend prioritizing these proposals and integrating them into the region's long-term previsions.

Due to certain limitations, we would highly recommend a further and a complete study on heat-exchangers to be installed in the facility (geometry, cost, effectiveness, types of heat

*Chapter III: Exploitation and Results.*

exchangers) in order to find the most suitable heat exchanger to install, this may depend on the needs of the company as well as the overall cost of the heat exchanger.

## REFERENCES:

- [1]. Full presentation of the Sonatrach Company 2016 <https://sonatrach.com/presentation>
  - [2]. Handbook of Liquefied Natural Gas, 2014 / Hand book of Natural Gas Transmission and Processing Principles and Practices 3<sup>rd</sup> Edition by Saeid Mokhatab, William A. Poe, John Y. Mak
  - [3]. Use of Expansion Turbines in Natural Gas Pressure Reduction Stations 2004
  - [4]. Documentation SONATRACH / Gas Processing 2007 [C.M].
  - [5]. MS 5002 GAS TURBINE A through D evolution [GE Power Systems Oil & Gas [gepower.com](http://gepower.com)]
  - [6]. <https://www.thermal-engineering.org/what-is-brayton-cycle-gas-turbine-engine-definition/>
  - [7]. GER-3567H GE Gas Turbine Performance Characteristics Frank J. Brooks GE Power Systems Schenectady, NY.
  - [8]. GER-3567H GE Gas Turbine Performance Characteristics Effect of ambient temperature
  - [9]. <https://classes.engineering.wustl.edu/mase-thermal-lab/me372b5.htm>
  - [10]. Al-Sayed AF 2008 Aircraft Propulsion and Gas Turbine Engines (Taylor & Francis).
  - [11]. Open Gas-Turbine Cycle Working Principal Brayton Cycle M. Bahrami ENSC 461 (S11) Brayton Cycle
  - [12]. Thermal calculations of ovens in the industry sector I. JACUBOWIEZ. 1998
  - [13]. Perry, R.H. and Chilton, C.H., eds., Chemical Engineers' Handbook, 5th ed., McGrawHill, 1973.
  - [14]. Energétique et Turbo Machine vol I
  - [15]. F. P. Incropera & D. P. DeWitt 1990 Fundamentals of Heat and Mass Transfer, 3rd edition, pp. 658–660. Wiley, New York
-

[16]. F. P. Incropera, D. P. DeWitt, T. L. Bergman & A. S. Lavine 2006 Fundamentals of Heat and Mass Transfer ,6th edition, pp 686–688. John Wiley & Sons US

[17]. Gas Turbine Engineering Handbook " Meherwan P. Boyce ".

[18]. Installations Energetiques 1 Les Installations à TAG Dr. K. Nehal

N.B: The rest of the equations used in this thesis belong to SONATRACH'S Constructor data and sheets or taken directly from the Distributed Control System super-computers.

