

الجمهورية الجزائرية الديمقراطية الشعبية  
THE PEOPLE'S DEMOCRATIC REPUBLIC OF ALGERIA

وزارة التعليم العالي والبحث العلمي  
The Ministry of Higher Education and Scientific Research



University of Saad Dahlab Blida 1  
Institute of Aeronautics and Space Studies  
Navigation Department



End of studies thesis

In order to obtain the Master's degree in Aeronautics

Option: CNS/ATM.

TITLE

*Implementation of GNSS signal generator*

*Proposed and supervised by:*

*Dr. DEHOUCHE Siham*

*Submitted by:*

*Ms. ZIAD Raounak*

*Ms. KHELILI Rabiaa Lydia*

*Jury members:*

*Dr.Zabot Amar*

*Dr.Mouffok Lila*

*President*

*Examiner*

*2023/2024*

## **ABSTRACT**

This thesis focuses on the design and implementation of a GNSS signal generator to simulate GPS and Galileo signals. The primary objective is to provide a controlled environment for the generation and validation of GNSS signals using the Simulink platform. The thesis explores the intricacies of signal structure, modulation techniques like BOC, and the signal generation process for both GPS and Galileo. The research contributes to the field of satellite navigation by enabling efficient testing of GNSS receivers without the reliance on live satellite signals, thus supporting further advancements in air traffic management and other critical industries.

## **Résumé**

Cette thèse porte sur la conception et la mise en œuvre d'un générateur de signaux GNSS pour simuler les signaux GPS et Galileo. L'objectif principal est de fournir un environnement contrôlé pour la génération et la validation des signaux GNSS en utilisant la plateforme Simulink. La thèse explore les structures de signal, les techniques de modulation comme le BOC, et le processus de génération de signaux pour GPS et Galileo. Cette recherche contribue au domaine de la navigation par satellite en permettant des tests efficaces des récepteurs GNSS sans dépendre des signaux satellitaires en direct, soutenant ainsi les avancées dans la gestion du trafic aérien et d'autres industries critiques.

## **ACKNOWLEDGMENTS**

First and foremost, we would like to express our deepest gratitude to our supervisor, Dr. DAHOUCHE Siham, whose expertise, patience, and unwavering support have guided us throughout the journey of completing this thesis.

We would also like to extend our heartfelt thanks to the entire faculty at Institute of Aeronautics and Space Studies for providing a stimulating academic environment and for their guidance throughout our studies. Special appreciation goes to Dr. BENCHEIKH Saliha the Head of Air Navigation Department.

We are deeply grateful to our colleagues and friends, for their companionship, motivation, and moral support. Our discussions, whether academic or otherwise, have enriched our experience and made this journey more enjoyable.

Finally, we would like to acknowledge all the participants in our research study and the members of jury for taking the time to review our work and for providing us with valuable feedback. Your insights and suggestions have greatly contributed to the improvement of this thesis.

Thank you all for being a part of this journey.

## *DEDICATION*

*From the depths of my heart, I dedicate this work to all these who are dear to me.*

*To my beloved mother,*

*No words can fully express my respect, eternal love, and deep appreciation for the sacrifices you have made for my education and well-being. Thank you for all the support and love you have given me since my childhood. May god preserve you and give you health and long life.*

*LYDIA*

## **DEDICATION**

Dedicated to my family and friends.

RAOUNAK ZIAD

# TABLE OF CONTENTS

ABSTRACT

ACKNOWLEDGMENTS

DEDICATION

TABLE OF CONTENTS

LIST OF TABLES

LIST OF FIGURES

LIST OF ABBREVIATIONS

LIST OF SYMBOLS AND NOTATIONS

GENERAL INTRODUCTION .....	1
CHAPTER 1. GLOBAL NAVIGATION SATELLITE SYSTEMS.....	3
1.1 INTRODUCTION .....	4
1.2 SATELLITE NAVIGATION SYSTEMS .....	4
1.2.1 GPS.....	4
1.2.2 The GLONASS system .....	6
1.2.3 GALILEO System .....	7
1.3 THE GNSS AND CNS/ATM .....	8
1.3.1 Communication.....	9
1.3.2 Navigation .....	9
1.3.3 Surveillance.....	10
1.3.4 Air Traffic Management.....	10
1.4 CNS/ATM IN ALGERIA.....	11
1.4.1 Communication Systems.....	11
1.4.2 Navigation Systems.....	12
1.4.3 Surveillance Systems .....	12
1.4.4 Air Traffic Management (ATM).....	13
1.4.5 Redundancy and Resilience.....	13

1.5	CONCLUSION .....	14
<b>CHAPTER 2.</b>	<b>GNSS SIGNALS .....</b>	<b>15</b>
2.1	INTRODUCTION .....	16
2.2	BOC MODULATION.....	16
2.2.1	<i>Definition</i> .....	16
2.2.2	<i>The types of BOC modulation</i> .....	17
2.3	THE GNSS SIGNALS .....	24
2.3.1	<i>The GPS signals</i> .....	24
2.3.2	<i>The GALILEO signals</i> .....	27
2.4	CONCLUSION .....	35
<b>CHAPTER 3.</b>	<b>DESIGN OF GNSS SIGNAL GENERATOR .....</b>	<b>35</b>
3.1	INTRODUCTION .....	37
3.2	GPS SIGNAL GENERATOR .....	37
3.2.1	<i>C/A Code Generation</i> .....	38
3.2.2	<i>Navigation Data Generation</i> .....	39
3.2.3	<i>P Code Generation</i> .....	39
3.3	GALILEO SIGNAL GENERATOR .....	44
3.4	SIGNAL DIFFERENCES .....	50
3.5	CONCLUSION .....	52
<b>GENERAL CONCLUSION</b> .....	<b>52</b>	
<b>REFERENCES</b> .....	<b>54</b>	

## LIST OF TABLES

Table 1:GPS Signals Characteristics. ....	27
Table 2: coefficient of sub-carrier of Altboc E5.....	32
Table 3: Galileo Signals Characteristics. ....	34



## LIST OF FIGURSES

Figure 1: CBOC modulation waveform.....	20
Figure 2: Modulation Scheme for the Galileo E1 Signals.....	28
Figure 3: spectrum for generated Galileo E1 signal.....	29
Figure 4: Modulation Scheme for the Galileo E5 signal.....	30
Figure 5: spectrum of signal E5.[12] .....	32
Figure 6: Modulation Scheme for the Galileo E6 Signals.....	33
Figure 7: GPS signal generator scheme.....	37
Figure 8: scheme for C/A code generation.....	38
Figure 9: scheme for P code generator.....	39
Figure 10: generated C/A code, P code and navigation data .....	42
Figure 11: spectrum of generated signal, C/A+P code.....	43
Figure 12: generated C/A code and P code.....	43
Figure 13: Galileo signal generator scheme.....	44
Figure 14: data channel scheme (OS).....	45
Figure 15: pilot channel scheme.....	45
Figure 16: Data channel PRS.....	46
Figure 17: generated BOC(15,2.5) and restricted data.....	48
Figure 18: generated Galileo E1 signal (OS).....	49
Figure 19: generated Galileo E1-A signal (PRS).....	49
Figure 20: generated E1 signal (OS and PRS).....	50

## **LIST OF ABBREVIATIONS**

- GNSS** – Global Navigation Satellite System
- GPS** – Global Positioning System
- BOC** – Binary Offset Carrier
- CNS/ATM** – Communication, Navigation, Surveillance/Air Traffic Management
- C/A Code** – Coarse/Acquisition Code
- PNT** – Positioning, Navigation, and Timing
- GLONASS** – Global Navigation Satellite System (Russia)
- PRN** – Pseudo-Random Noise
- VOR** – VHF Omnidirectional Range
- DME** – Distance Measuring Equipment
- ADS-B** – Automatic Dependent Surveillance-Broadcast
- ADS-C** – Automatic Dependent Surveillance-Contract
- MBOC** – Multiplexed Binary Offset Carrier
- QPSK** – Quadrature Phase Shift Keying
- BPSK** – Binary Phase Shift Keying
- CBOC** – Composite Binary Offset Carrier
- ALTBOC** – Alternative Binary Offset Carrier
- AWGN** – Additive White Gaussian Noise
- FDP** – Flight Data Processing
- MTP** – Multi-Track Processing
- WAAS** – Wide Area Augmentation System
- EGNOS** – European Geostationary Navigation Overlay Service
- VSAT** – Very Small Aperture Terminal
- CASM** – Coherent Adaptive Sub-carrier Modulation
- L1** – First GPS Frequency Band (1575.42 MHz)
- L2** – Second GPS Frequency Band (1227.60 MHz)
- L5** – Third GPS Frequency Band (1176.45 MHz)
- E1** – Galileo First Frequency Band (1575.42 MHz)
- E5** – Galileo Second Frequency Band (1176.45 MHz)

**E6** – Galileo Third Frequency Band (1278.75 MHz)  
**OCX** – Next Generation Operational Control System  
**CM** – Civil Moderate Code  
**CL** – Civil Long Code  
**I5** – In-phase Component of L5 Signal  
**Q5** – Quadrature-phase Component of L5 Signal  
**SNR** – Signal-to-Noise Ratio  
**CDMA** – Code Division Multiple Access  
**FDMA** – Frequency Division Multiple Access  
**RTK** – Real-Time Kinematic  
**INS** – Inertial Navigation System  
**P(Y) Code** – Precision (Y) Code used for military GPS applications  
**FANS** – Future Air Navigation Systems  
**MCS** – Master Control Station  
**TT&C** – Telemetry, Tracking, and Command  
**AFSCN** – Air Force Satellite Control Network  
**CIC** – Clock and Integration Counter

## LIST OF SYMBOLS AND NOTATIONS

$f$  – Frequency

$f_{L1}$  – L1 Carrier Frequency (1575.42 MHz)

$f_{L2}$  – L2 Carrier Frequency (1227.60 MHz)

$f_{L5}$  – L5 Carrier Frequency (1176.45 MHz)

$A$  – Amplitude

$\phi$  – Phase

$\lambda$  – Wavelength

$T$  – Time or Period

$T_c$  – Chip Duration

$T_s$  – Symbol Duration

$P$  – Power

$C/N_0$  – Carrier-to-Noise Ratio

$d$  – Distance

$v$  – Velocity

$a$  – Acceleration

$R$  – Range

$\Delta t$  – Time Delay

$\theta$  – Angle

$\rho$  – Pseudorange

$\omega$  – Angular Frequency

$\nu$  – Doppler Shift

$\tau$  – Delay

$\alpha$  – Signal Attenuation Coefficient

$\beta$  – Modulation Index

$B$  – Bandwidth

$I(t)$  – In-phase Component

$Q(t)$  – Quadrature Component

$S(t)$  – Signal Function

$g(t)$  – BOC Signal

$m$  – Modulation Parameter

$n$  – Noise

$C/A$  – Coarse/Acquisition Code

$P(t)$  – Precision Code

$C_k$  – Code Sequence

$h(t)$  – Non-Return-to-Zero (NRZ) Code

$sign(\cdot)$  – Sign Function

$\cos(\cdot)$  – Cosine Function

$\sin(\cdot)$  – Sine Function

$rect(\cdot)$  – Rectangular Pulse

$A_{Si}$  – Amplitude of Subcarrier Signal

$P_{Si}$  – Power of Signal Component

$\gamma$  – Elevation Angle

$D(t)$  – Data Sequence

$\delta$  – Code Chip Offset





## GENERAL INTRODUCTION

Global Navigation Satellite Systems (GNSS) have become indispensable in modern technology, offering essential services such as precise positioning, navigation, and timing (PNT) that are critical across a wide range of industries. From everyday applications like smartphone navigation and logistics to more complex systems like air traffic management and defense, GNSS technologies have transformed how we interact with our environment and conduct various operations. The most prominent GNSS systems in operation today are the American Global Positioning System (GPS) and the European Galileo system, both providing global coverage for civilian and military use.

The evolution of GNSS technologies has been driven by advances in satellite communication and signal processing techniques. As GNSS systems develop, they incorporate new features, such as advanced signal structures and modulation schemes, which enhance performance, accuracy, and resistance to interference. Galileo, for instance, is designed with advanced signal architectures aimed at improving precision and availability, while GPS has undergone upgrades to introduce new civilian signals and improve its robustness. Understanding these GNSS signals, their structures, and the methods for generating them is critical for furthering research, development, and testing of GNSS technologies.

This thesis is structured to cover the background, technical details, and practical implementation of GNSS signal generation:

The first chapter provides an in-depth overview of GNSS as a whole. It begins with an introduction to GNSS, explaining the fundamental principles and importance of satellite-based navigation systems. It also covers the major global systems—GPS, GLONASS, and Galileo—and their unique characteristics. Additionally, this chapter delves into the role of GNSS within the Communication, Navigation, and Surveillance/Air Traffic Management (CNS/ATM) framework, which is critical in ensuring safe and efficient airspace management. Finally, the chapter examines the current state and applications of GNSS in Algeria, highlighting the country's integration of GNSS in national infrastructure and services.



The second chapter shifts focus to the technical characteristics of GNSS signals, with a particular emphasis on the Binary Offset Carrier (BOC) modulation, which is widely used in modern GNSS signals for its advantages in spectral separation and reduced interference. The chapter begins by defining BOC modulation and its types, before exploring the specific GNSS signals used by both GPS and Galileo systems. For GPS, signals such as L1, L1C, L2C, and L5 are analyzed in terms of their structure, purpose, and improvements over previous versions. Similarly, for Galileo, signals like E1, E5, and E6 are examined, offering insight into how Galileo's signal architecture contributes to its superior accuracy and reliability.

The third chapter presents the core contribution of this thesis: the design and implementation of a GNSS signal generator. This chapter provides a detailed description of the simulation tools and methodologies used, particularly within the Simulink environment. The design of the signal generator is discussed in terms of its architecture, signal flow, and the specific algorithms implemented for generating both GPS and Galileo signals. Furthermore, the chapter includes validation and testing procedures, ensuring that the generated signals are representative of real-world GNSS signals and suitable for use in research and technology development.

The primary objective of this research is the simulation and design of a GNSS signal generator capable of generating accurate GPS and Galileo signals within the Simulink framework. By simulating these signals in a controlled environment, the work enables detailed testing and validation of GNSS technologies without reliance on live satellite signals. This offers significant benefits for researchers and engineers, allowing for the development and testing of GNSS-related systems in a flexible and repeatable manner. The successful implementation of the GNSS signal generator will contribute to advancing the state of GNSS research and provide valuable tools for further innovation in this critical field.

## **CHAPTER 1. GLOBAL NAVIGATION SATELLITE SYSTEMS**

## **1.1 Introduction**

Global Navigation Satellite Systems (GNSS) are constellations of satellites that transmit positioning, navigation, and timing data to receivers on Earth. GNSS systems provide global coverage and include well-known constellations such as the United States' GPS, Russia's GLONASS, Europe's Galileo, and China's BeiDou. GNSS receivers use this data to determine location, speed, direction, and time. The performance of GNSS is assessed using four criteria: Accuracy, Integrity, Continuity, and Availability.

## **1.2 Satellite navigation systems**

### **1.2.1 GPS**

The Global Positioning System (GPS) is a satellite-based navigation system that provides accurate positioning, navigation, and timing (PNT) services to users worldwide. Developed and maintained by the United States, GPS uses a constellation of orbiting satellites to transmit signals that allow receivers on Earth to calculate their precise location. GPS is vital for both civilian and military applications, offering global coverage. The system is divided into three key segments, Space, Control, and User segment with each playing a crucial role in ensuring the accuracy and reliability of GPS services.[13]

#### ***The space segment***

The GPS Space Segment consists of a constellation of 24 to 32 satellites in four semi-circular orbits with a radius of 26,560 km and an inclination of 55°, with each satellite broadcasting signals used by GPS receivers on the ground to measure positions

The GPS satellites are divided into blocks, with each block representing a generation of satellites with similar characteristics [1]

#### **The different GPS blocks**

**Block I:** Eleven Navigation Development Satellites were launched between 1978 and 1985. They weighed about 845 kg and had a planned average life of 4.5 years, although some of them lasted up to 10. They were capable of giving positioning service through L1 and L2 signals.

**Block II and IIA:** These Operational Satellites consist of 28 satellites in total that were launched from 1989 to 1997. They were designed to be autonomous and had a design life of 7.5 to 10 years. They were capable of giving positioning service through L1 and L2 signals

**Block IIR and IIR-M:** These Modernized Satellites represent a modernized version of the IIR family, including a new military M code signals and the more robust L2C signal. They were launched from September 2005 to August 2009 and had a design life of 12 years

**Block IIF:** This Follow-on Operational Satellites block constitutes an improvement of Block IIA based on the applicability of new technology and new improvements in the design. They were launched from May 2010 to August 2016 and had a design life of 12 years.

**Block III:** This is the most recent block, with the first satellite launched in 2018. It is needed to complete the deployment of L2C and L5 signal capabilities that began with the modernized GPS IIR-M and by improving interoperability and jam resistance. They provide the fourth civil signal on L1 band (L1C) interoperable with other GPS signals and bring the full capability to... The main new functionality of these satellites is the implementation of AUTONAV capability, in which satellites can determine their orbits and compute their own navigation message autonomously. They have the capability to measure distances between themselves and transmit data to other satellites or to the control.

The GPS Space Segment is crucial for providing positioning, navigation, and timing services to civilian and military users worldwide. The United States is committed to maintaining the availability of at least 24 operational GPS satellites.[2][3]

### ***The control segment***

The GPS Control Segment comprises a global network of ground facilities that track the GPS satellites, monitor their transmissions, perform analysis, and send commands and data to the constellation. Key elements of the GPS Control Segment include:

Master Control Station (MCS) — Located at Schriever Air Force Base in Colorado Springs, CO, the MCS is responsible for managing the GPS satellite constellation. It generates navigation messages and sends commands to the satellites using ground antennas

Monitor Stations—There are currently 11 monitor stations operated by the U.S. Air Force and 11 National Geospatial-Intelligence Agency (NGA) stations. These stations track the satellites, collecting range measurements, atmospheric information, satellite's orbital information, clock errors, velocity, right ascension, and declination. The data is sent to the MCS

Alternate Master Control Station—Another MCS exists as backup at Vandenberg Air Force Base in California

Ground Antennas—Four ground antennas monitor and track the satellites from horizon to horizon. They also transmit correction information to individual satellites

Additional Facilities—Other facilities include Air Force Satellite Control Network (AFSCN) remote tracking stations, which help during the early stages of satellite launches and throughout their lifetimes

The GPS Control Segment has undergone significant modernizations over the years, with the latest effort being the Next Generation Operational Control System (OCX)

OCX will enable the control of both legacy and modernized GPS satellites, enhancing cybersecurity and resilience for the next generation of GPS operations.[1]

### **1.2.2 The GLONASS system**

Glonass was Russia's satellite navigation system in the 80's. The system was designed by the military, and was initially deployed for military use only. The first step towards civilian use of the system was taken in 1998 at the ICAO (International Civil Aviation Organization) FANS (Future Air Navigation Systems) committee conference, where the system was presented and it was decided to offer Glonass services free of charge for air navigation.

The Glonass system was declared operational on September 24 1993, but the nominal constellation of 24 satellites was reached on January 18 1996 [12]. The system encountered funding problems after the collapse of the USSR, and by the year 2000 the constellation contained just six operational satellites, three years later a modernization phase was launched.

### ***The space segment***

The Glonass constellation consists of 24 satellites at an altitude of 19,100 km in three circular orbits, with a period of revolution of 11h 15min 44s seconds [12]. Since the system's creation in 1982, the Glonass constellation has undergone enormous changes and developments in three satellite generations, the first generation containing the first satellites launched up to the year 2000, the satellites had a lifetime of three years, the second generation called Glonass M which constituted the first phase of modernization and re-commissioning of the system which contained only six satellites in operation, the first satellite was launched in 2003, a total of 41 M satellites were launched up to 2013, their lifetimes increased to seven years. The latest generation is Glonass K, the first satellite of which was launched in 2011, with a service life of ten years. Lighter than the first and second generation satellites (750 kg), they will broadcast signals modulated using CDMA (Code Division Multiple Access) technology, unlike their predecessors using FDMA (Frequency Division Multiple Access).[4]

### *The control segment*

The control segment comprises two main parts: the System Control Center and the Command Tracking Stations (CTS). All the components of the control segment are located on Russian territory.

### **1.2.3 GALILEO System**

Galileo is Europe's global satellite navigation system (GNSS), providing improved positioning and timing information with significant implications for many European services and users.

### *The space segment*

Constellation will comprise satellites spread evenly around three orbital planes at an altitude of 23222 km and inclined at an angle of 56 degrees to the equator. Each satellite will take about 14 hours to orbit the Earth. The constellation may be complemented by Galileo auxiliary satellites, which occupy orbital slots that are not part of the baseline constellation and are not

defined a priori. Auxiliary satellites that are in the baseline orbital planes may be repositioned to any given nominal slot within each orbital plane, depending on maintenance or service evolution needs

Galileo's ground segment consists of two control centers (Oberpfaffenhofen and Fucino), five Telemetry, Tracking and Command stations (Kiruna, Kourou, Redu, Reunion Island and New Caledonia Island), a worldwide network of sensor stations and a worldwide network of uplink stations. TT&C stations receive 71 status and health information from the satellites. In parallel, sensor stations receive the navigation signals. All these information is sent to both control centres, where it is processed and analysed.

### *The control segment*

The control centres calculate the updated navigation message, as well as commands to the satellites to correct, for example, for any orbital drift or an anomalous situation in a satellite platform. The updated navigation information and the commands to the satellites are transmitted through the uplink and TT&C stations, respectively. This is a continuous process, which aims to maintain the system providing the best possible performance and service.[6]

## **1.3 The GNSS and CNS/ATM**

Communications, Navigation, Surveillance/Air Traffic Management (CNS/ATM) is an advanced system that employs state-of-the-art technologies to improve the efficiency and safety of air traffic management. CNS/ATM integrates multiple systems to enable:

- o Faster, more reliable communication between pilots and air traffic controllers,
- o More precise navigation for aircraft,
- o Closer monitoring of aircraft in flight for enhanced safety.

This integrated system supports the growing demand for air traffic, offering a modernized framework that promotes both safety and efficiency. One of the key elements driving this modernization is the Global Navigation Satellite System (GNSS), which plays a vital role in enhancing the core functions of communication, navigation, and surveillance within the CNS/ATM framework.

### 1.3.1 Communication

Communication is a critical component of the CNS/ATM system, enabling a real-time link between pilots, air traffic controllers, and other aircraft. CNS/ATM primarily uses VHF communication systems to ensure this connectivity, particularly in areas where traditional ground-based communication infrastructure is limited or unavailable. GNSS enhances this communication network by providing precise timing information, which ensures that data is transmitted and received with minimal delay, reducing the risk of miscommunication and improving the overall coordination of flight operations.

By integrating GNSS, the system ensures that air traffic controllers have real-time access to flight data, allowing for more accurate and timely decision-making. GNSS-based communication improves the reliability of data transmission, especially in remote areas or over oceanic regions, where maintaining consistent communication is critical for safety.

### 1.3.2 Navigation

Navigation is another vital aspect of CNS/ATM, enabling pilots to determine their position and navigate safely within airspace. Modern navigation systems integrated into CNS/ATM include:

- o GPS (Global Positioning System): Provides highly accurate positioning information, essential for both en-route and precision approaches.
- o VOR (VHF Omnidirectional Range): A short-range radio navigation system used for aircraft navigation.
- o DME (Distance Measuring Equipment): Measures the distance between the aircraft and ground stations to assist in navigation.

GNSS, particularly GPS, has revolutionized air navigation by offering continuous global coverage and precision. This allows aircraft to follow more efficient routes, reducing the need for reliance on ground-based navigation aids like VOR and DME. GNSS-based navigation systems are crucial for modern Area Navigation (RNAV) and Required Navigation Performance (RNP) systems, enabling aircraft to fly flexible, optimized flight paths.

With GNSS, air traffic is not constrained by traditional ground-based navigation infrastructure, leading to more efficient flight operations. The satellite-based system also allows



for greater accuracy in precision approaches and landings, particularly when combined with augmentation systems such as WAAS (Wide Area Augmentation System) and EGNOS (European Geostationary Navigation Overlay Service).

### **1.3.3 Surveillance**

Surveillance within the CNS/ATM framework ensures that aircraft positions are closely monitored for both safety and efficiency. Traditional radar systems have long been the backbone of surveillance, but GNSS has significantly improved surveillance capabilities through systems like:

- o ADS-B (Automatic Dependent Surveillance-Broadcast): A system where aircraft broadcast their position, velocity, and other flight data using GNSS information.
- o ADS-C (Automatic Dependent Surveillance-Contract): A contract-based surveillance system where aircraft automatically send position reports at regular intervals.

GNSS enhances surveillance by providing highly accurate and real-time positioning data. ADS-B, in particular, has become a key technology, allowing aircraft to broadcast their position not only to ground stations but also to other nearby aircraft, enhancing situational awareness and reducing the risk of mid-air collisions. This system also allows for better airspace management, as it enables more aircraft to safely operate in a given airspace with reduced separation distances, increasing air traffic capacity.

### **1.3.4 Air Traffic Management**

Air Traffic Management (ATM) refers to all the activities required to ensure the safe and efficient flow of air traffic. The modern ATM system not only relies on traditional flight planning but also incorporates advanced trajectory optimization systems to improve airspace utilization.

GNSS plays a crucial role in ATM by providing real-time positioning information that allows for more efficient air traffic management. With GNSS, air traffic controllers can track the exact position of each aircraft, enabling dynamic flight path adjustments to optimize airspace usage. This precision reduces the need for holding patterns and allows for more efficient scheduling of arrivals and departures.

One of the key advantages of GNSS in ATM is its contribution to trajectory-based operations. GNSS allows for the precise planning and execution of optimized flight paths, reducing flight times, fuel consumption, and environmental impact. The system also supports time-based air traffic flow management, ensuring smoother operations at busy airports and reducing delays.

## **1.4 CNS/ATM IN ALGERIA**

The Communication, Navigation, and Surveillance/Air Traffic Management (CNS/ATM) systems in Algeria form the backbone of the country's modern air traffic management infrastructure, ensuring safe, efficient, and reliable air navigation services across national and international airspaces. Managed by the Etablissement Nationale de la Navigation Aérienne (ENNA), these systems are critical for the oversight of Algeria's rapidly growing air traffic needs, aligning with international aviation standards.

### **1.4.1 Communication Systems**

ENNA's communication systems are designed to ensure seamless air-to-ground and ground-to-ground communication between air traffic controllers, pilots, and regional aviation entities. The primary components of the communication system include:

- **AFTN/RSFTA Messaging:** The Aeronautical Fixed Telecommunication Network (AFTN), also known as RSFTA in the region, is the cornerstone of Algeria's aeronautical messaging. This system facilitates the transmission of flight plans, weather information, and other critical messages between national and international air navigation facilities, ensuring real-time updates for flight operations.
- **CPDLC (Controller-Pilot Data Link Communication):** In the event of VHF failure, ENNA's Air-Ground Processing (AGP) servers manage CPDLC systems, allowing for direct digital communication between pilots and air traffic controllers. This enhances communication resilience, especially during high traffic or emergency situations.

ENNA's communication infrastructure also features redundant servers, secure IP/LAN networks, and specialized backup links to ensure continuous service with high availability, even in cases of technical issues or network failures.

### 1.4.2 Navigation Systems

Algeria's air navigation systems provide accurate, real-time information to pilots and air traffic controllers, ensuring that aircraft operate within safe and efficient flight paths. Key systems include:

- **GNSS (Global Navigation Satellite Systems):** The integration of GPS and Galileo signals offers enhanced precision for navigation across Algeria's diverse landscape, which includes both urban airspaces and the vast desert regions of the south. These systems are integral for supporting aircraft en route, during landing, and while operating in areas with limited radar coverage.
- **ADS-B (Automatic Dependent Surveillance-Broadcast):** This next-generation surveillance technology allows aircraft to broadcast their location and velocity in real-time to both air traffic control and other nearby aircraft. In Algeria, ADS-B is particularly crucial for monitoring flights over remote regions like the Sahara Desert, where traditional radar infrastructure is sparse.

### 1.4.3 Surveillance Systems

Algeria's surveillance systems form a robust layer of situational awareness, ensuring that air traffic controllers can monitor aircraft movements in real-time across the nation's airspace. ENNA employs a combination of radar-based and satellite-based surveillance:

- **Primary and Secondary Radar Systems:** Radar coverage is concentrated around major airports and high-traffic zones, ensuring complete surveillance of these areas. Primary radar systems detect aircraft without transponders, while secondary radar systems track aircraft equipped with transponders for more detailed information.
- **ADS-C (Automatic Dependent Surveillance-Contract):** In Algeria's remote southern regions, where desert terrain and mountains make radar deployment challenging, the ADS-C system provides reliable coverage. ADS-C relies on contracts established between the aircraft and ground stations to relay positional data, ensuring that aircraft in these areas remain under surveillance.

#### **1.4.4 Air Traffic Management (ATM)**

The Air Traffic Management (ATM) component is central to ensuring the safe and efficient movement of aircraft through Algeria's airspace. ENNA is responsible for handling a variety of air traffic management functions, including:

- **Flight Plan Processing:** ENNA's Flight Data Processing (FDP) server manages the reception, decoding, and integration of flight plans using the ASTERIX format. This system is vital for coordinating air traffic controllers and pilots in real-time, particularly in busy airspace or during complex flight operations.
- **Radar and Flight Plan Correlation:** The Multi-Track Processing (MTP) server correlates radar data with flight plans, ensuring that aircraft movements are accurately tracked and aligned with their planned routes. This reduces the likelihood of deviations or mid-flight conflicts.
- **Indra ATM Platform:** ENNA is currently transitioning to a new Indra ATM platform that offers advanced integration between radar, ADS-B, flight plans, and data processing. This new system, combined with next-generation servers and virtual infrastructures, will provide greater resiliency and operational efficiency for air traffic management in Algeria.

#### **1.4.5 Redundancy and Resilience**

Given the critical nature of CNS/ATM services for both national and international flights, ENNA has invested in a highly redundant infrastructure to ensure continuous service availability. Key components include:

- High-availability servers for the processing of both communication and surveillance data.
- Redundant communication links, such as the E1 backup lines with the EPS protocol, ensuring that the system remains operational even in the event of primary link failures.
- VSAT satellite systems that provide backup international communication capabilities with neighboring countries such as Tunisia, Morocco, France, Spain, and Italy.
- Multiplexers, modems, and frequency generators to maintain the integrity of communication and data processing across the entire system.

## **1.5 Conclusion**

This chapter has outlined the key role of Global Navigation Satellite Systems (GNSS) in modern satellite navigation, with a focus on GPS, GLONASS, and Galileo systems. It also examined the integration of GNSS within the Communication, Navigation, and Surveillance/Air Traffic Management (CNS/ATM) framework, emphasizing its impact on enhancing air traffic efficiency and safety. The discussion on Algeria's CNS/ATM infrastructure highlights the country's adoption of GNSS technologies to meet growing air traffic needs. This sets the foundation for further analysis of GNSS applications and advancements in air traffic management.

## CHAPTER 2. GNSS SIGNALS

## 2.1 Introduction

Binary Offset Carrier (BOC) modulation is an advanced signal modulation technique that plays a crucial role in enhancing the performance of Global Navigation Satellite Systems (GNSS) signals. This modulation scheme introduces a binary offset in the carrier signal, which improves the separation of multiple signals transmitted by different satellites and reduces interference from adjacent frequencies. BOC modulation is instrumental in elevating the signal-to-noise ratio (SNR), thereby increasing the resilience of GNSS signals to noise and external disturbances.

In the context of GNSS, BOC modulation is utilized in both GPS and Galileo systems. For the GPS system, BOC modulation enhances the clarity and accuracy of signals by mitigating signal interference and improving multipath resistance. Similarly, the European Galileo system leverages BOC modulation to provide high-precision navigation services, benefiting from the enhanced signal separation and robustness it offers. By addressing challenges associated with signal detection in complex environments, BOC modulation significantly contributes to the overall effectiveness and reliability of GPS and Galileo signals, ensuring precise and reliable positioning for users worldwide. This abstract underscores the importance of BOC modulation in advancing GNSS technology and improving navigation system performance globally.

## 2.2 BOC modulation

### 2.2.1 Definition

Binary offset carrier modulation (BOC modulation) was developed by John Betz in order to allow interoperability of satellite navigation systems. It is currently used in the US GPS system, Indian IRNSS system and in Galileo .

Binary Offset Carrier Signals are a particular case of BCS signals with a representation vector formed by +1's and -1's alternating in a particular defined way. Two notations can be found in the literature to define the BOC signals.

boc signal is a new technique that uses a square wave subcarrier and is defined by the following formula:

$$g_{BOC}(t) = \sum_{n=-\infty}^{+\infty} (-1)^{c_n} (-1)^n \cdot P_{BOC}(t - nT_C) \quad 2.1$$

The first model defines the BOC modulation as the result of multiplying the PRN code with a sub-carrier which is equal to the sign of a sine or a cosine waveform, yielding so-called sine-phased or cosine-phased BOC signals respectively. According to this definition, the expression of the sine-phased BOC signal would be:

$$S(t) = c(t) \text{sign} [\sin(2\pi f_s t)] \quad 2.2$$

$$S(t) = c(t) \text{sign} [\cos(2\pi f_s t)] \quad 2.3$$

$$c(t) = \sum_k C_K h(t - kT_C) \quad 2.4$$

Where:

- $c_k$  is the code sequence waveform,
- $f_s$  is the sub-carrier frequency.
- and  $h(t)$  is the Non Return to Zero (NRZ) code materialization with value 1 over the support  $[0, T_C]$

where  $pT_e(t)$  describes the chip waveform and is broken up into  $n$  rectangular pulses of duration  $T_c/n$  with amplitude  $\pm 1$ . It is important to note that in this case the sine-phasing or cosine-phasing is considered as part of the chip waveform definition.

No matter what definition we choose to describe the BOC modulation in the time domain, the BOC signal is commonly referred to as BOC( $f_s, f_c$ ) where  $f_s = m \cdot 1.023$  and  $f_c = n \cdot 1.023$  so that generally one only says BOC( $m, n$ ) for simplicity. Moreover, unless it is indicated in a different way, when we talk about BOC signals we will always mean the sine-phased variant.

The parameter  $\Phi$  is of great interest when analysing BOC signals. It is defined as two times the ratio between the sub-carrier and the chip frequency as follows:

$$\phi = 2 \frac{f_s}{n} = \frac{m}{n}$$

$\Phi$  represents the number of half periods of the sub-carrier that fit in a code chip so that this ratio can be even or odd. When  $\Phi$  is even, the two definitions presented above for the BOC modulation coincide since we can consider the sub-carrier as included in the chip waveform. However, when  $\Phi$  is odd the second definition is not valid any more.[7]

### 2.2.2 The types of BOC modulation

***MBOC Modulation (Multiplexed Binary Offset Carrier):***



Nearly twenty months after the EU and the US signed the Agreement on the Promotion, Provision and use of Galileo and GPS Satellite-Based Navigation Systems and Related Applications an optimized signal waveform named MBOC (Multiplexed Binary Offset Carrier modulation) was proposed by a common group of experts of the EU and US for GPS L1C and Galileo E1 OS MBOC (Multiplexed Binary Offset Carrier) modulation is a type of spread spectrum modulation used in satellite navigation systems like Galileo and modernized GPS. The key features of MBOC modulation are:

- It combines a SinBOC(1,1) signal with a SinBOC(6,1) signal.
- The main objective was to have the power spectral density (PSD) of the MBOC signal be identical for the GPS L1C and Galileo E1 OS signals, ensuring high interoperability between the two systems.
- MBOC provides improved tracking performance and multipath mitigation compared to traditional BPSK modulation used in legacy GPS.

In summary, MBOC is an optimized modulation scheme that combines different BOC signals to enable interoperability between GPS and Galileo satellite navigation systems.

The normalized PSD of MBOC is defined as:

$$G_{\text{MBOC}(6,1,1/11)}(f) = \frac{10}{11} G_{\text{BOC}(1,1)}(f) + \frac{1}{11} G_{\text{BOC}(6,1)}(f) \quad 2.5$$

where is  $G_{\text{MBOC}(6,1,1/11)}$  the PSD of the BOC signal. There are a variety of methods producing MBOC(6,1,1/11) signals, which are typically produced by two different methods, CBOC and TMBOC.

***CBOC modulation (Composite Binary Offset Carrier):***

CBOC (Composite Binary Offset Carrier) modulation used in GNSS (Global Navigation Satellite System) signals. It is an extension of the BOC modulation technique, designed to further enhance the signal acquisition, tracking, and multipath resistance capabilities of GNSS receivers.

CBOC modulation combines multiple BOC modulated signals with different spreading codes and sub-carrier frequencies into a single, composite signal. This results in a more complex signal structure, but with improved performance characteristics.

In CBOC modulation, the signals are combined coherently, meaning that they are in phase with each other. This coherent combination allows the receiver to exploit the benefits of multiple BOC modulated signals while maintaining a single, unified signal structure.

One of the main benefits of CBOC modulation is its improved multipath resistance compared to traditional BOC modulation. Multipath effects occur when a GNSS signal is reflected off various surfaces, such as buildings or mountains, causing multiple versions of the signal to be received by the receiver. This can lead to inaccuracies in positioning and timing calculations. CBOC modulation helps mitigate these multipath effects by combining multiple BOC signals, effectively averaging out the impact of multipath interference.

CBOC modulation has been adopted in modern GNSS signals, such as the Galileo E1 Open Service signal and the BeiDou B1C signal, due to its superior performance and robustness against interference and multipath effects.[1]

CBOC: the subcarrier of a CBOC signal comprises four-level symbols formed by the weighted sum of different BOC subcarrier symbols, and the model of the CBOC signal can be defined as

$$\begin{cases} S_{CBOC}(t) = \sum_{-\infty}^{+\infty} C_k P_{CBOC}(t - kT_C), \\ P_{CBOC}(t) = W_1 P_{BOC(1,1)} + W_2 P_{BOC(6,1)}(t), \end{cases} \quad 2.6$$

Where  $W_1$  and  $W_2$  denote amplitude weighting factors satisfying  $W_1^2 + W_2^2 = 1$ .

CBOC can be implemented using three signal models: CBOC ('+'), CBOC ('-'), and CBOC ('+/-').

$$S_{CBOC(+)}(t) = \omega_1 S_{SinBOC(1,1)}(t) + \omega_2 S_{SinBOC(6,1)}(t) \quad 2.7$$

$$S_{CBOC(-)}(t) = \omega_1 S_{SinBOC(1,1)}(t) - \omega_2 S_{SinBOC(6,1)}(t) \quad 2.8$$

$$S_{CBOC(+/-)}(t) = \begin{cases} \omega_1 S_{SinBOC(1,1)}(t) + \omega_2 S_{SinBOC(6,1)}(t) & \text{for even chips} \\ \omega_1 S_{SinBOC(1,1)}(t) - \omega_2 S_{SinBOC(6,1)}(t) & \text{for odd chips} \end{cases} \quad 2.9$$

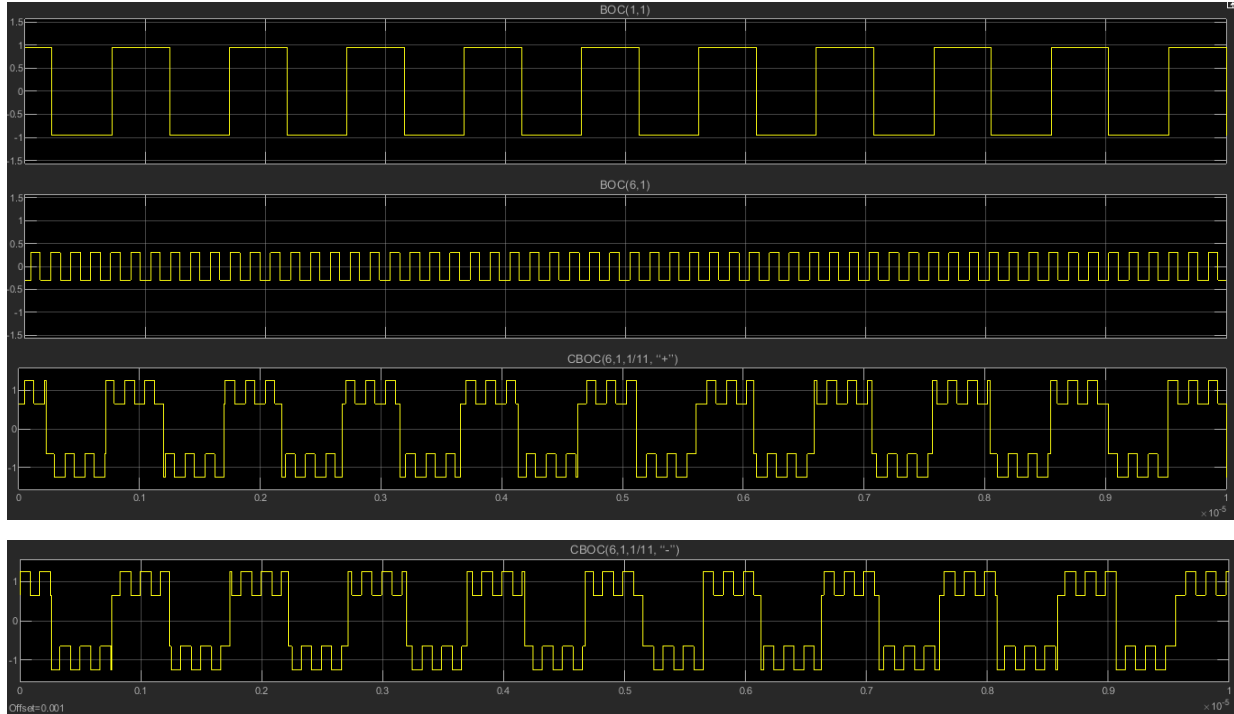

Figure 1: CBOC modulation waveform.

***TBOC modulation (Time-Multiplexed Binary Offset Carrier):***

TBOC (Time-Multiplexed Binary Offset Carrier) modulation is a technique used in modernized GNSS signals, particularly in the L1C signal of the GPS system. It is a combination of BOC modulation and time-division multiplexing, designed to improve the signal acquisition and tracking capabilities of the receiver.

In TBOC modulation, both the pilot and data signals are modulated onto the same carrier frequency using BOC modulation. However, they are transmitted at different times, with the pilot signal being transmitted for a short period of time, followed by the data signal. This time-multiplexing approach allows the receiver to more easily acquire and track the signal, as it can focus on the pilot signal for initial acquisition and then switch to the data signal for tracking and positioning.

Its power spectral density is defined as follows:

$$\frac{10}{11}G_{BOC(1,1)}(f) + \frac{1}{11}G_{BOC(6,1)}(f) \tag{2.10}$$

The TBOC modulation technique helps to improve the overall accuracy and reliability of the GNSS system, as well as its robustness against interference and multipath effects. There are several variations of TBOC modulation, including TBOC-pilot, TBOC-data, and TBOC-hybrid, which are used for different purposes within the GNSS signal structure.

***ALTBOC modulation (Alternative BOC modulation):***

The Alternative BOC modulation (ALTBOC) is conceptually very similar to the BOC modulation but with an important difference, since contrary to BOC, ALTBOC provides high spectral isolation between the two upper main lobes and the two lower main lobes (considering the I and Q phases separately). This is accomplished by using different codes for each main lobe. any BOC signal could be correlated with a BPSK replica having as chip rate the sub-carrier frequency of the original BOC signal. Of course the prize is the loss of power, but processing the upper or lower main lobe would make no difference since both are modulated with the same PRN code. On the other hand, if we would do the same with the ALTBOC signal, we could still receive each main lobe separately since different codes would be needed. This is very interesting because ALTBOC allows thus keeping the BOC implementation simple while permitting to differentiate the lobes.

the Alternative BOC modulation uses a complex sub-carrier so that the spectrum is not split up, as is the case of BOC, but simply shifted to higher or lower frequencies.

the ALTBOC signal is defined as the product of a PRN code sequence with a complex sub-carrier. This convention covers even and odd ratios with no necessary modification.

The ALTBOC signal can be formed by two (only data signals) or four codes (data and pilot). If we have only two codes, the signal is composed of only data and can be expressed as follows:

$$S_{altboc}(t) = C_L C_S(t) + C_U C_S^*(t) \quad 2.11$$

Where  $C_L$  and  $C_S$  are the lower and upper codes respectively. As we can recognize from (1), what we are basically doing by multiplying the lower code and the upper code by the complex sub-

carrier and its conjugate is approximately to shift the lower code to  $f_s$  and the upper code to  $+f_s$ . In fact, this would be the case if we would multiply with the exponential function:

$$C_s(t) = \text{sign}[\cos(2\pi f_s t)] + j\text{sign}[\sin(2\pi f_s t)] = C_r(t) + jS_r(t) \quad 2.12$$

### **CASM modulation**

CASM is a modulation technique used in satellite navigation systems, particularly in the Galileo E1 signal. It involves the combination of a QPSK signal and an additional Binary Offset Carrier (BOC) modulation to form a constant envelope multiplexed signal.

The BOC modulation in CASM is denoted by  $\text{BOC}(f_s, f_c)$ , where  $f_s$  and  $f_c$  represent specific parameters of the modulation scheme. For example,  $\text{BOC}(15, 2.5)$  is used in the Galileo E1 signal. CASM allows for the transmission of multiple signals in the same frequency band by using different BOC modulations for each signal component. The power distribution between the signal components can be adjusted by varying the modulation indexes.

In the context of GPS modernization, CASM was proposed as a solution for transmitting the three GPS signals in the L1 band. Tapez une équation ici. The power of each signal component in CASM depends on the modulation index  $m$ , which is the only parameter that is not set. The total average power is maintained constant in the CASM modulation.

CASM offers a way to achieve a constant envelope signal by combining multiple BOC modulations, allowing for efficient power amplification and reduced interference between signal components. However, it introduces additional complexity compared to simpler modulation schemes like BOC.[7][1]

The signal combining them using modulation is expressed by:

$$s(t) = I_0(t) \cos(\omega_c t + m\phi_s(t)) - Q_0 \sin(\omega_c t + m\phi_s(t)) \quad 2.13$$

Such as:

$$I_0 = \sqrt{P_I} S_I(t)$$

$$Q_0(t) = \sqrt{p_Q} S_2(t)$$

$$\phi_s(t) = S_3 S_k(t) \quad (k = 1 \text{ ou } 2)$$

With:

$\omega_c$ : the carrier frequency;

$m$ : the modulation index;

$\phi_s$ : the carrier phase;

Using the sine and cosine characteristics;

$$S(t) = I(t) \cos(\omega_c t) - Q(t) \sin(\omega_c t) \quad 2.14$$

Such as:

$$I(t) = \sqrt{P_I} S_I(t) \cos(m) - \sqrt{p_Q} S_2(t) S_3 S_k(t) \sin(m) \quad 2.15$$

$$Q(t) = \sqrt{p_Q} S_2(t) \cos(m) + \sqrt{P_I} S_I(t) S_3 S_k(t) \sin(m) \quad 2.16$$

As for the choice of  $S_k(t)$ , there are two possibilities:

- $S_k(t) = S_I(t)$  :

$S_I(t) = \pm 1$ , so  $(S_I(t))^2 = 1$ ,

the equations can be written as follows:

$$I(t) = \sqrt{P_I} S_I(t) \cos(m) - \sqrt{p_Q} S_2(t) S_3(t) S_I(t) \sin(m) \quad 2.17$$

$$Q(t) = \sqrt{p_Q} S_2(t) \cos(m) + \sqrt{P_I} S_3(t) \sin(m) \quad 2.18$$

The respective power of the signals are given by:

$$P_{S1} = P_I \cos^2(m)$$

$$P_{S2} = P_Q \cos^2(m)$$

$$P_{S3} = P_I \sin^2(m)$$

The modulation index can be calculated:

$$m = \tan^{-1} \sqrt{\frac{P_{S3}}{P_{S1}}}$$

- $S_k(t) = S_2(t)$ :

$S_2(t) = \pm 1$ , so  $(S_2(t))^2 = 1$ ,

the equations can be written as follows:

$$I(t) = \sqrt{P_I} S_I(t) \cos(m) - \sqrt{p_Q} S_3(t) \sin(m) \quad 2.19$$

$$Q(t) = \sqrt{p_Q} S_2(t) \cos(m) + \sqrt{P_I} S_1(t) S_3(t) S_2(t) \sin(m) \quad 2.20$$

The respective power of the signals are given by:

$$P_{S1} = P_I \cos^2(m)$$

$$P_{S2} = P_Q \cos^2(m)$$

$$P_{S3} = P_I \sin^2(m)$$

The modulation index can be calculated:

$$m = \tan^{-1} \sqrt{\frac{P_{S3}}{P_{S2}}}$$

## 2.3 The GNSS signals

### 2.3.1 The GPS signals

GPS signals are the radio signals transmitted from GPS satellites to GPS receivers on the ground. Each satellite transmits on multiple frequencies, each with its own modulation and characteristics.

#### *L1 signal*

The L1 signal is the oldest and most widely used GPS signal, primarily for civilian purposes. It operates at a frequency of 1575.42 MHz and is modulated with two codes:

- C/A Code (Coarse/Acquisition Code) for civilian users
- P(Y) Code for military use (encrypted)

The modulation of the L1 signal is done using binary phase shift keying (BPSK). The equation for the carrier signal is:

$$s_{L1}(t) = A_{L1} \cos(2\pi f_{L1} t + \phi) \quad 2.21$$

where:

- $A_{L1}$  is the amplitude of the L1 carrier,
- $f_{L1} = 1575.42$  MHz is the carrier frequency,
- $\phi$  is the phase.

The signal is modulated by either the C/A or P(Y) code using BPSK, where:

$$s_{\text{modulated}}(t) = s_{L1}(t) \cdot C/A(t) \quad 2.22$$

The C/A code is a pseudorandom sequence that repeats every millisecond and has a chip rate of 1.023 Mbps. This helps users acquire and track the GPS satellites.

### *L1C signal*

L1C is a modernized civilian GPS signal transmitted on the same L1 frequency (1575.42 MHz). It offers enhanced performance for civilian users compared to the older C/A code, especially in difficult environments such as urban canyons or areas with heavy foliage.

L1C uses a multiplexed binary offset carrier (MBOC) modulation scheme, which is a combination of BPSK and BOC(1,1). The MBOC modulation improves the signal's robustness against interference and multipath effects. The BOC(1,1) portion has a spectral separation that improves performance in challenging conditions.[5]

The L1C signal can be described mathematically as:

$$s_{L1C}(t) = A_{L1C} \cos(2\pi f_{L1} t) \cdot \text{MBOC}(t) \quad 2.23$$

Here, the MBOC modulation provides a broader frequency spectrum, resulting in more accurate and reliable signal reception.

### *L2C signal*

The **L2C** signal is the second civilian GPS signal, operating at a frequency of **1227.60 MHz**. It was introduced to provide better precision, especially when combined with the L1 signal through dual-frequency techniques to mitigate errors caused by the ionosphere.

L2C is modulated with two separate codes:

- **CM Code** (Civil Moderate)
- **CL Code** (Civil Long)



The modulation of L2C uses **BPSK** for both CM and CL codes. These codes help to improve signal tracking and acquisition in adverse conditions. The **CM code** has a chip rate of **511.5 kbps**, while the **CL code** has a much lower chip rate of **511 bps**.

The L2C signal can be described as:

$$s_{L2C}(t) = A_{L2C} \cos(2\pi f_{L2}t) \cdot (CM(t) + CL(t)) \quad 2.24$$

where:

- $f_{L2} = 1227.60$  MHz is the L2 carrier frequency,

CM(t) and CL(t) are the moderate and long codes, respectively.[1]

### *L5 signal*

The L5 signal is the most advanced civilian GPS signal, operating at a frequency of 1176.45 MHz. It is primarily intended for safety-critical applications such as aviation and provides higher accuracy, better signal strength, and resistance to interference.

L5 uses quadrature phase shift keying (QPSK) modulation, which allows it to carry more data compared to BPSK signals. The L5 signal is broadcast with two data components:

- I5 (In-phase) component
- Q5 (Quadrature-phase) component

The L5 signal can be expressed mathematically as:

$$s_{L5}(t) = A_{L5} (\cos(2\pi f_{L5}t) \cdot I5(t) + \sin(2\pi f_{L5}t) \cdot Q5(t)) \quad 2.25$$

where:

- $f_{L5} = 1176.45$  MHz,
- $I5(t)$  and  $Q5(t)$  are the in-phase and quadrature-phase signals, respectively.

The combination of these two orthogonal components in QPSK modulation makes the L5 signal more efficient in terms of bandwidth usage and robust against signal degradation.[2]

Signal	Carrier Frequency	Modulation	Code Used	Code Length	Data Rate (Navigation Message)
L1 C/A	1575.42 MHz	BPSK	C/A code (PRN)	1023 chips	50 bps
L1C	1575.42 MHz	BOC(1,1)	L1C code (Pilot)	10230 chips	50 bps

Signal	Carrier Frequency	Modulation	Code Used	Code Length	Data Rate (Navigation Message)
L2C	1227.60 MHz	BPSK	CM/CL codes	10230 chips (CL)	50 bps
L5	1176.45 MHz	BPSK(10)	I/Q codes	10230 chips	50 bps
L2 P(Y)	1227.60 MHz	BPSK	P(Y) code	$6.1871 \times 10^{12}$ chips	50 bps

Table 1:GPS Signals Characteristics.

### 2.3.2 The GALILEO signals

#### *E1 signal*

The Galileo E1 signal is a crucial component of the Galileo satellite navigation system, designed to provide accurate positioning and timing services.

The E1 signal operates at a central frequency of 1575.42 MHz, which is in the L-band, similar to the GPS L1 signal.

It employs a Composite Binary Offset Carrier (CBOC) modulation scheme, specifically CBOC(6,1,1/11), which combines the benefits of BOC and enhances signal robustness against interference and multipath effects, And has a chipping rate of 1.023 MHz, with a code length of 4092 chips, resulting in a repetition period of 4ms. The pilot signal (E1-C) utilizes a secondary code of length 25 chips, extending its repetition interval to 100ms.

Signal Design: The signal design utilizes a multichannel modulation scheme known as Coherent Adaptive Sub-Carrier Modulation (CASM), ensuring a constant power envelope for the transmitted signal, which is beneficial for power amplifier efficiency.[8]

The E1 signal is designed to provide high accuracy and reliability for various applications, including the Open Service (OS) and Safety of Life (SoL) services. The minimum power received from the E1 signal is significantly higher than that of the C/A code from GPS, enhancing its performance in challenging environments.

The E1 signal consists of three main components:

- $e_{E1-A}$ : A restricted access signal that is encrypted and primarily used for public regulated services (PRS), E1-A is modulated onto the quadrature component.

- $e_{E1-B}$ : A data signal that carries navigation data and integrity messages, the  $E1 - B$  component includes the Integrity Navigation Message (I/NAV)  $D_{E1-B}$  and it is modulated with the subcarrier  $SC_{E1-B,a}$  and  $SC_{E1-B,b}$ .
- $e_{E1-C}$ : A pilot signal that does not carry data, modulated with the subcarrier  $SC_{E1-C,a}$  and  $SC_{E1-C,b}$  enhancing the correlation properties and allowing for longer integration times.

The C channel use a primary code of length  $N_p = 4092$  chips and a secondary code of length  $N_s = 24$  chips.

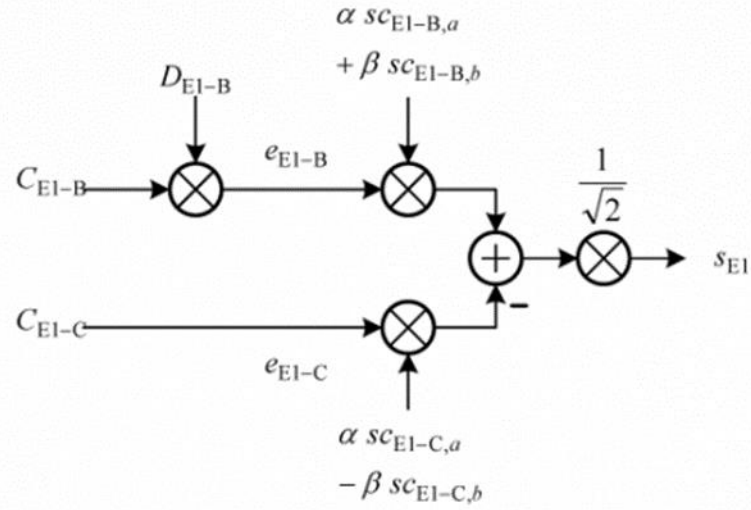

Figure 2: Modulation Scheme for the Galileo E1 Signals.

$$e_{E1-B} = \sum_{i=-\infty}^{+\infty} \left[ C_{E1-B,|i|_{L_{E1-B}}} D_{E1-B,|i|_{DC_{E1-B}}} \text{rect}_{T_{C,E1-B}}(t - iT_{C,E1-B}) \right] \quad 2.26$$

$$e_{E1-C} = \sum_{i=-\infty}^{+\infty} \left[ C_{E1-C,|i|_{L_{E1-C}}} \text{rect}_{T_{C,E1-C}}(t - iT_{C,E1-C}) \right] \quad 2.27$$

Such as:

$DC_{E1-B}$ : number of code chips per symbol.

$|i|_L$ : I modulo L.

$T_{C,E1-B}, T_{C,E1-C}$ : duration of the PRN code chips of component B and C.

The E1 signal can be expressed by:

$$S_{E1} = \frac{1}{\sqrt{2}} \left( e_B(t) (\alpha \text{sgn}(\sin(2\pi f_0 t)) + \beta \text{sgn}(\sin(2\pi 6(f_0 t)))) - e_C(t) (\alpha \text{sgn}(\sin(2\pi(6f_0 t)))) + \beta \text{sgn}(\sin(2\pi f_0 t)) \right). \quad 2.28$$

With:

the fundamental frequency  $f_0 = 1.023 \text{ mhz}$  .

the parameters  $\alpha = \sqrt{\frac{10}{11}}$  et  $\beta = \sqrt{\frac{1}{11}}$  .

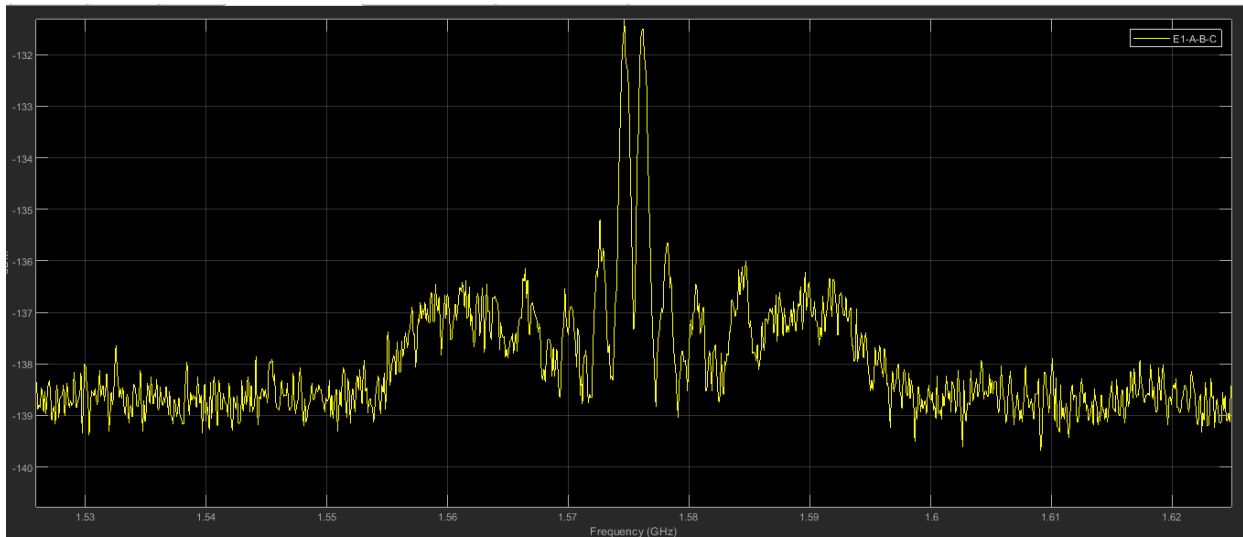

Figure 3: spectrum for generated Galileo E1 signal.

### *E5 signal*

The Galileo E5 signal is designed to provide high-precision positioning and timing services.

The E5 signal operates at a central frequency of 1176.45 MHz, and the which is also in the L-band, similar to the E1 signal but at a higher frequency and has a chipping rate of 10.23 MHz,

The signal has a wide bandwidth of 51.150 MHz, which is unprecedented in satellite navigation systems, allowing for improved signal quality and resistance to interference.

The E5 signal utilizes Alternate Binary Offset Carrier(AltBOC) modulation, specifically the AltBOC(15,10) configuration. This modulation technique combines the advantages of BOC and enhances the signal's spectral efficiency, improving performance in multipath environments.

It is composed of two signals:

E5a signal

The E5 signal primarily supports the open service (OS) and consists of two components:

- $e_{5a-I}$  data channel: from the F/NAV navigation data stream  $D_{E5a-I}$  modulated with the unencrypted ranging code  $C_{E5a-I}$ .
- $e_{5a-Q}$  pilot channel: from the unencrypted ranging code  $C_{E5b-Q}$ .

The pilot channel aids in improving the signal tracking performances by providing a reference for the receiver.

The E5b signal

The E5 signal is designed for the safety of life (SOL) service and similarly consists of two components:

- $e_{5b-I}$  data channel: from the I/NAV navigation data stream  $D_{E5b-I}$  modulated with the unencrypted ranging code  $C_{E5b-Q}$ . this channel carries navigation data that includes integrity messages crucial for civil aviation safety.
- $e_{5b-Q}$  pilot channel: from the unencrypted ranging code  $C_{E5b-Q}$ .

It serves a similar purpose in enhancing performance.[1][9]

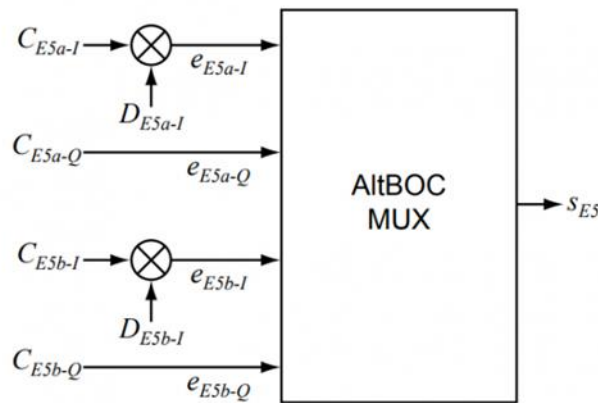

Figure 4: Modulation Scheme for the Galileo E5 signal.

These components are defined as follows:

$$e_{E5a-I}(t) = \sum_{i=-\infty}^{+\infty} [ C_{E5a-I,|i|_{L_{E5a-I}}} d_{E5a-I,|i|_{DC_{E5a-I}}} \text{rect}_{T_{C,E5a-I}}(t - iT_{C,E5a-I}) ] \quad 2.29$$

$$e_{E5a-Q}(t) = \sum_{i=-\infty}^{+\infty} [ C_{E5a-Q,|i|_{L_{E5a-Q}}} \text{rect}_{T_{C,E5a-Q}}(t - iT_{C,E5a-Q}) ] \quad 2.30$$

$$e_{E5b-I}(t) = \sum_{i=-\infty}^{+\infty} [ C_{E5b-I,|i|_{L_{E5b-I}}} d_{E5b-I,|i|_{DC_{E5b-I}}} \text{rect}_{T_{C,E5b-I}}(t - iT_{C,E5b-I}) ] \quad 2.31$$

$$e_{E5b-Q}(t) = \sum_{i=-\infty}^{+\infty} [ C_{E5b-Q,|i|_{L_{E5b-Q}}} \text{rect}_{T_{C,E5b-Q}}(t - iT_{C,E5b-Q}) ] \quad 2.32$$

The signal is expressed by

$$\begin{aligned} S_{ES}(t) = & \frac{1}{2\sqrt{2}} \left( e_{E5a-I}(t) + je_{E5a-Q}(t) \right) \left[ SC_{E5-S}(t) - jSC_{E5-S} \left( t - \frac{T_{S,E5}}{4} \right) \right] + \\ & \frac{1}{2\sqrt{2}} \left( e_{E5b-I}(t) + je_{E5b-Q}(t) \right) \left[ SC_{E5-S}(t) - jSC_{E5-S} \left( t - \frac{T_{S,E5}}{4} \right) \right] + \\ & \frac{1}{2\sqrt{2}} \left( \bar{e}_{E5a-I}(t) + j\bar{e}_{E5a-Q}(t) \right) \left[ SC_{E5-P}(t) - jSC_{E5-P} \left( t - \frac{T_{S,E5}}{4} \right) \right] + \\ & \frac{1}{2\sqrt{2}} \left( \bar{e}_{E5b-I}(t) + j\bar{e}_{E5b-Q}(t) \right) \left[ SC_{E5-P}(t) - jSC_{E5-P} \left( t - \frac{T_{S,E5}}{4} \right) \right] \end{aligned} \quad 2.33$$

The respective dotted signal component  $\bar{e}_{E5a-I}$ ,  $\bar{e}_{E5a-Q}$ ,  $\bar{e}_{E5b-I}$  and  $\bar{e}_{E5b-Q}$  represent the signals produced according to these equations:

$$\bar{e}_{E5a-I} = e_{E5a-Q} e_{E5b-I} e_{E5b-Q} \quad 2.34$$

$$\bar{e}_{E5a-Q} = e_{E5a-I} e_{E5b-I} e_{E5b-Q} \quad 2.35$$

$$\bar{e}_{E5b-I} = e_{E5b-Q} e_{E5a-I} e_{E5a-Q} \quad 2.26$$

$$\bar{e}_{E5b-Q} = e_{E5b-I} e_{E5a-I} e_{E5b-Q} \quad 2.37$$

The parameters  $SC_{E5-S}(t)$  and  $SC_{E5-P}(t)$  represent the four valued subcarrier functions for the simple signals and the produced signals respectively:

$$SC_{E5-S}(t) = \sum_{i=-\infty}^{\infty} AS_{|i|_B} \text{rect}_{\frac{T_{S,E5}}{8}}(t - iT_{S,E5}/8) \quad 2.38$$

$$SC_{E5-P}(t) = \sum_{i=-\infty}^{\infty} AP_{|i|_B} \text{rect}_{\frac{T_{S,E5}}{8}}(t - iT_{S,E5}/8) \quad 2.39$$

The coefficients  $AS_i$  and  $AP_i$  are given in the table below:

1	0	1	2	3	4	5	6	7
$2AS_i$	$\sqrt{2}+1$	1	-1	$-\sqrt{2}$ +1	$-\sqrt{2}$ -1	-1	1	$\sqrt{2}+1$
$2AP_i$	$-\sqrt{2}+1$	1	-1	$-\sqrt{2}$ -1	$\sqrt{2}-1$	-1	1	$-\sqrt{2}+1$

Table 2: coefficient of sub-carrier of Altboe E5.

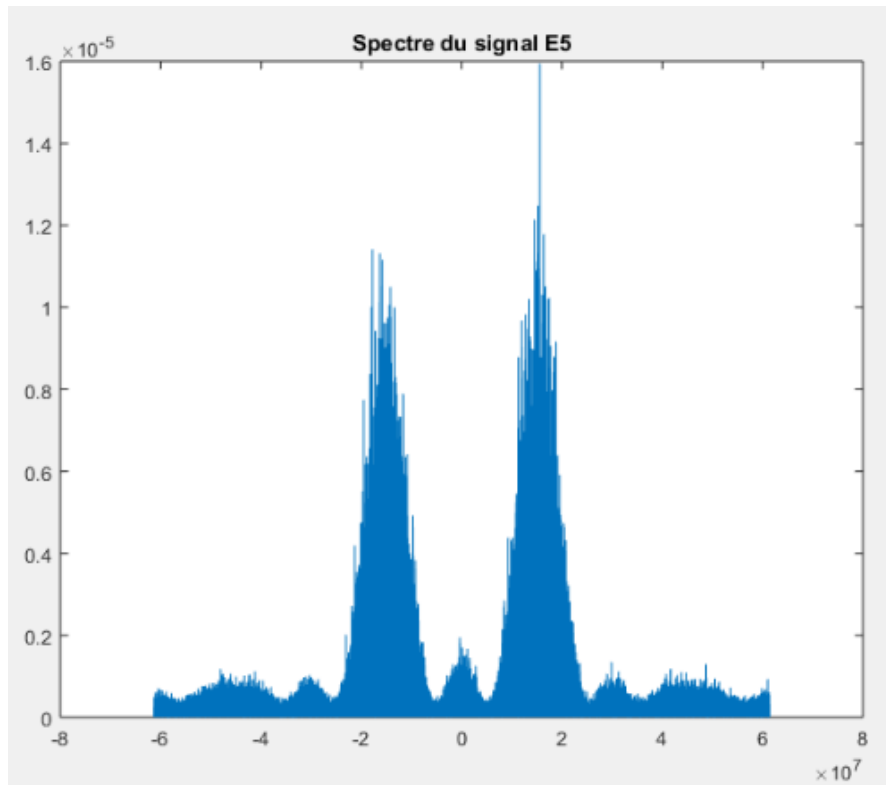

Figure 5: spectrum of signal E5.[12]

### ***E6 signal***

The E6 signal is one of the frequency bands used in the European satellite navigation system Galileo, which is part of the Global Navigation Satellite System (GNSS). The E6 signal operates in the 1260 to 1300 MHz frequency range and serves specialized applications, primarily for high-accuracy positioning and public regulated services (PRS).

E6 signals are modulated with a binary phase shift keying BPSK (binary phase shift keying) at a carrier frequency of 1278.75 MHz, which is used by all satellites and shared through a CDMA RF channel access mode.[10][11]

Therefore, as shown in Galileo OS SIS ICD, the transmitted Galileo E6 signal consists of the following components, both (pilot and data components) are combined on the same carrier component

- $e_{6-B}$  from the C/NAV navigation data stream  $D_{E6-B}$  modulated with the encrypted ranging code  $C_{E6-B}$

$e_{6-C}$  (pilot component) from the ranging code  $C_{E6-C}$ .

a data component (E6-B) component allowing the transmission of 448 bits per second and a pilot (E6-C) component.

Both channels allow to encrypt the information at signal level.

This is graphically shown as follows:

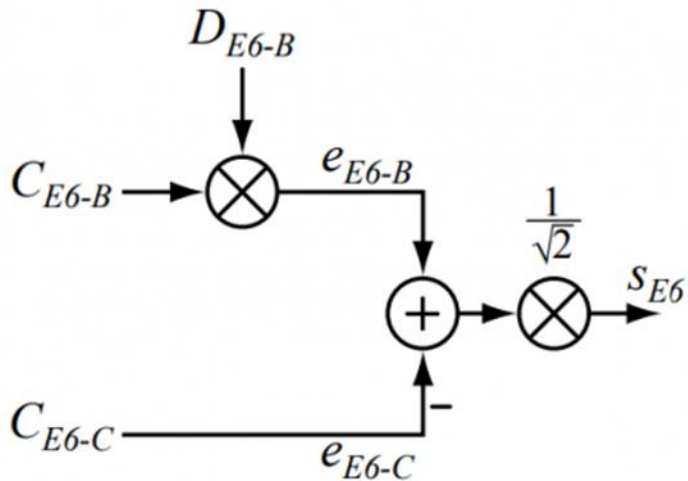

Figure 6: Modulation Scheme for the Galileo E6 Signals.

The signal is expressed by the following equation:

$$S_{E6}(t) = \frac{1}{\sqrt{2}} [e_{E6-B}(t) - e_{E6-C}(t)] \tag{2.40}$$

$e_{E6-B}(t)$  and  $e_{E6-C}(t)$  being given in the following equations:



$$e_{E6-B}(t) = \sum_{i=-\infty}^{+\infty} \left[ C_{E6-B,|i|_{DC_{E6-B}}} d_{E6-B,|i|_{DC_{E6-B}}} \text{rect}_{T_{C,E6-B}}(t - iT_{C,E6-B}) \right] \quad 2.41$$

$$e_{E6-C}(t) = \sum_{i=-\infty}^{+\infty} \left[ C_{E6-B,|i|_{L_{E6-C}}} \text{rect}_{T_{C,E6-C}}(t - iT_{C,E6-C}) \right] \quad 2.42$$

Signal	Carrier Frequency	Modulation	Code Used	Code Length	Data Rate (Navigation Message)
E1 OS	1575.42 MHz	CBOC (Composite BOC)	C/A code, PRS	4 ms (4092 chips)	125 bps (E1B), 25 bps (E1C)
E5a	1176.45 MHz	BPSK(10)	Pilot code, Data code	10230 chips	50 bps
E5b	1207.14 MHz	BPSK(10)	Pilot code, Data code	10230 chips	50 bps
E6	1278.75 MHz	BPSK(5)	Pilot code, Data code	5115 chips	1 kbps

Table 3: Galileo Signals Characteristics.

## **2.4 Conclusion**

This chapter has provided an overview of GNSS signals, focusing on the Binary Offset Carrier (BOC) modulation and its various types, which enhance signal performance in satellite navigation. It has also examined the specific signals used by GPS and Galileo systems, such as GPS's L1, L1C, L2C, and L5, and Galileo's E1, E5, and E6. Understanding these signals and their characteristics is essential for improving the accuracy, reliability, and interoperability of GNSS systems.

## **CHAPTER 3. DESIGN OF GNSS SIGNAL GENERATOR**

### 3.1 Introduction

A GNSS signal generator mimics the behavior of actual GNSS satellites, producing signals identical in structure to those transmitted by satellite constellations like GPS (Global Positioning System), Galileo, and others. These signals are used to evaluate and optimize the performance of GNSS receivers under controlled conditions. By simulating the environment of a satellite constellation, the GNSS signal generator provides a cost-effective and efficient way to test systems without the need for live satellite signals.

Key features of GNSS signal generators include:

- **Frequency Generation:** Typically generating signals in the L1, L2, and L5 frequency bands for GPS and Galileo.
- **Modulation Schemes:** The signals are modulated using techniques such as Binary Phase Shift Keying (BPSK) and Quadrature Phase Shift Keying (QPSK).
- **Multi-Satellite Simulation:** The generator can simulate multiple satellites simultaneously, allowing for testing across different scenarios such as urban environments, open fields, and more.
- **Control over Signal Parameters:** Parameters such as signal power, Doppler shift, noise, and interference can be adjusted to simulate real-world conditions.

### 3.2 GPS signal generator

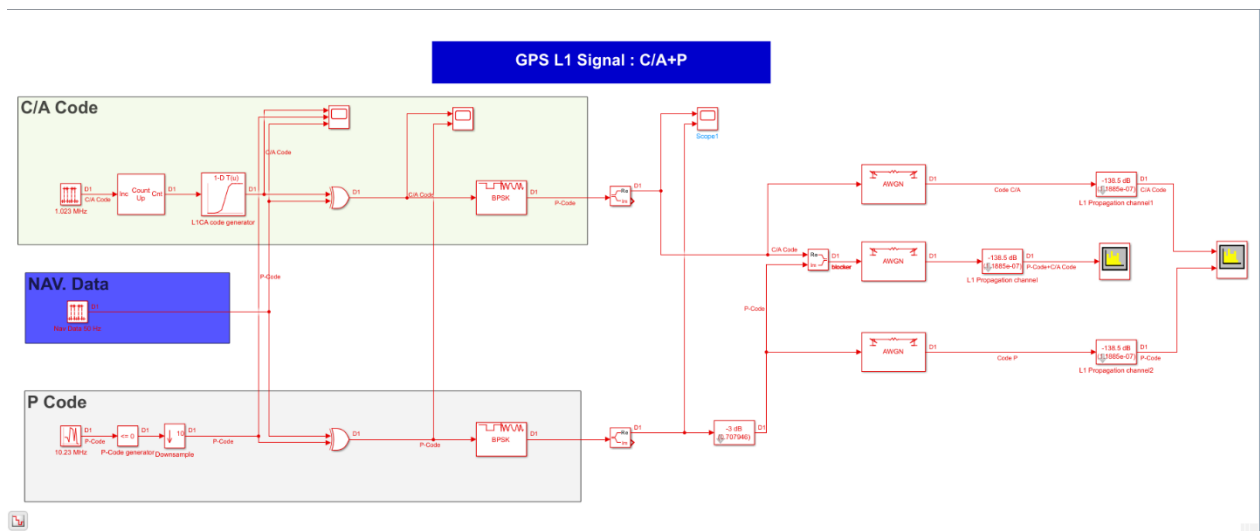

Figure 7: GPS signal generator scheme.

A GPS signal generator is designed to simulate the signals transmitted by GPS satellites, providing an essential tool for testing GPS receivers without relying on live satellite signals. It generates various components of the GPS signal, such as the C/A code, navigation data, and P code, which are combined to form the complete GPS signal. These signals help receivers determine their position and timing with high accuracy. The following sections describe the process of generating each signal component.

### 3.2.1 C/A Code Generation

The C/A (Coarse/Acquisition) code is a critical component of GPS signal transmission, responsible for identifying each satellite and enabling precise timing. The following figure illustrates the process of generating the C/A code, which is essential for encoding the satellite identification sequence (PRN code) and combining it with the navigation data.

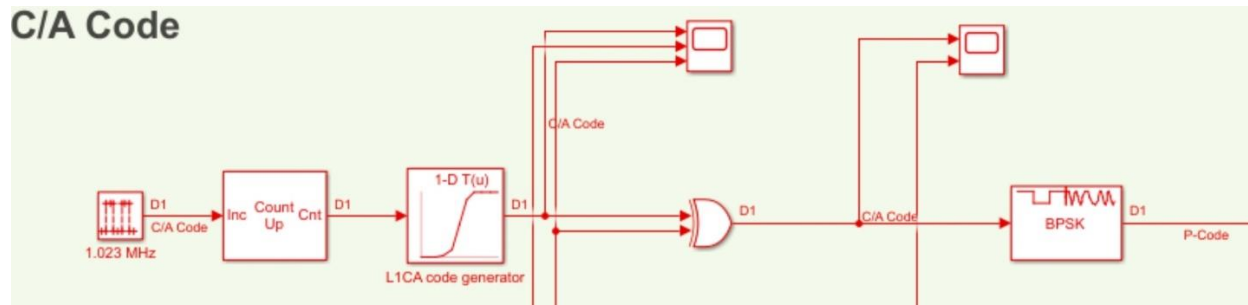

Figure 8: scheme for C/A code generation.

**Oscillator (1.023 MHz):** This block generates a square wave signal at 1.023 MHz, which is the chipping rate for the C/A code. It acts as the clock source for the C/A code generation.

**Counter:** This block is connected to the oscillator and increments its value with each clock pulse. It counts up to 1022 (for a total of 1023 chips per PRN code).

**L1 C/A Code Generator (Look-Up Table):** This is the actual PRN (Pseudorandom Noise) code generator. It selects the PRN code based on the satellite being simulated and outputs the C/A code (a unique sequence of 1023 chips).

**1-to-0 TTL:** This component indicates the transitions in the digital signal from 1 to 0, often used for timing and synchronization purposes.

**Multiplier:** The output C/A code is then multiplied by the Navigation Data. This combines the satellite identification code (C/A code) with the GPS message data (navigation data).

### 3.2.2 Navigation Data Generation

NAV Data (50 Hz): This block generates the navigation data, which is the actual information being transmitted by the GPS satellite. It includes timing, satellite health, orbital information, etc., and operates at a data rate of 50 Hz.

Multiplier: The navigation data is combined (multiplied) with the C/A code to create the signal that will be transmitted by the satellite

### 3.2.3 P Code Generation

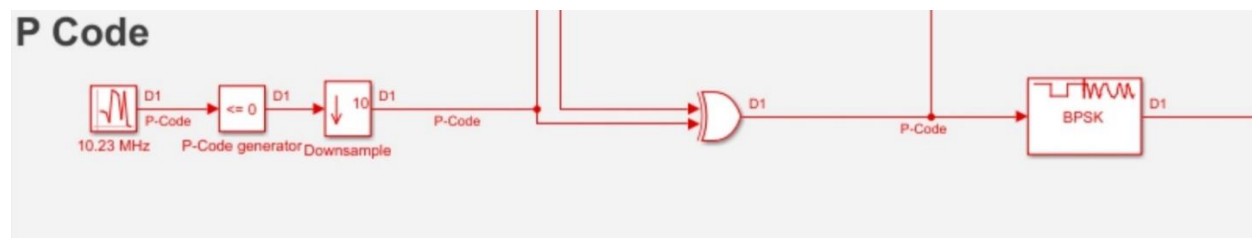

Figure 9: scheme for P code generator.

P-Code Generator (10.23 MHz): The P-code is another GPS signal component, operating at a much higher rate (10.23 MHz) compared to the C/A code. It is used for military purposes and encrypted GPS signals (P(Y) code).

Downsample Block: The P-code operates at a higher frequency (10.23 MHz), so it is often downsampled to match the rate needed for transmission or simulation.

Multiplier (P-Code): Similar to the C/A code, the P-code is modulated with the navigation data to form a part of the GPS L1 signal for military use.

### BPSK Modulators

- BPSK Modulator (For C/A Code): After the C/A code is multiplied by the navigation data, it is modulated using Binary Phase Shift Keying (BPSK). BPSK shifts the phase of the carrier signal to encode binary data (in this case, the combined C/A code and navigation data).
- BPSK Modulator (For P-Code): The same process happens with the P-Code and navigation data, modulating them onto a carrier signal using BPSK.

AWGN Blocks (For Both C/A Code and P-Code Paths)

- **AWGN (Additive White Gaussian Noise):** These blocks introduce noise into the signal path to simulate the real-world environment where GPS signals are subject to interference and noise. The AWGN blocks are added after the BPSK modulation to simulate transmission over the atmosphere and other environmental factors.
- These blocks add different noise levels to the C/A code and P-code signals, which are critical for testing how the signal performs under realistic conditions. Attenuators (-138.5 dB and -3 dB)
- **Attenuators (-138.5 dB and -3 dB):** These blocks reduce the signal power by a specified amount. The GPS signals received on Earth are very weak (around -130 dB), so this block simulates the signal attenuation experienced during transmission over long distances from the satellites to Earth.
- The attenuators represent signal loss in the propagation channel, accounting for the signal weakening over the large distance from satellites in orbit.

### **Propagation Channel**

- The L1 propagation channel block simulates the real-world effects on the GPS signal as it travels through the atmosphere. It includes the noise and attenuation experienced during transmission.
- **C/A Code Propagation Channel:** Simulates the channel the C/A code-modulated signal would pass through, including noise, attenuation, and environmental factors.
- **P-Code Propagation Channel:** Simulates the transmission channel for the P-Code-modulated signal.

### **Output Scopes**

- **Scope1 (C/A Code) and Scope2 (P-Code):** These blocks display the signal waveform for observation and analysis after it has passed through the propagation channel and noise blocks. They are used to monitor how the signal looks after modulation, noise addition, and attenuation.

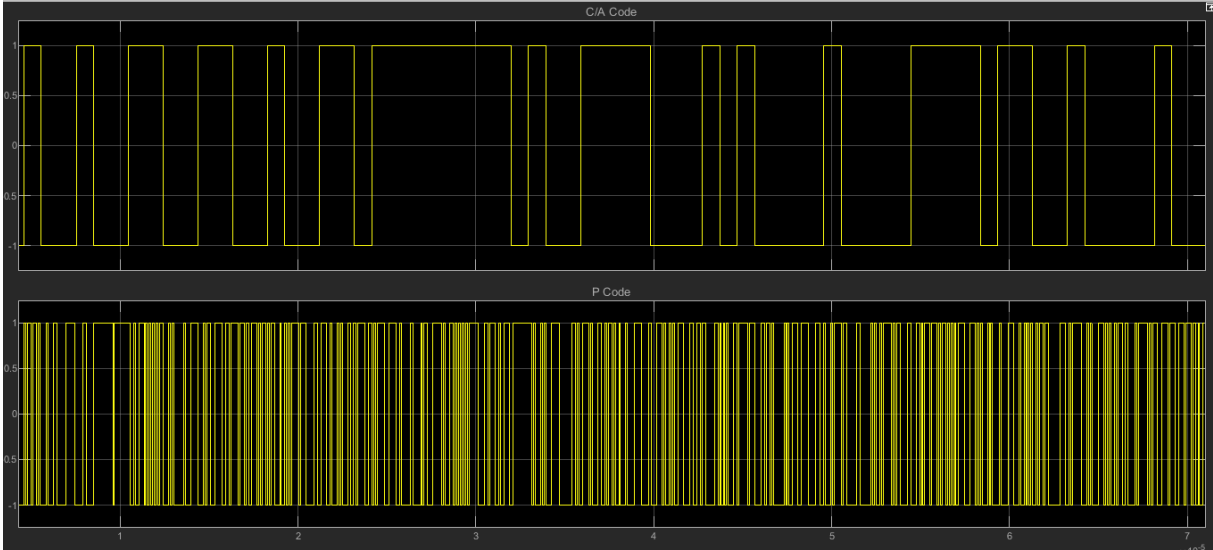



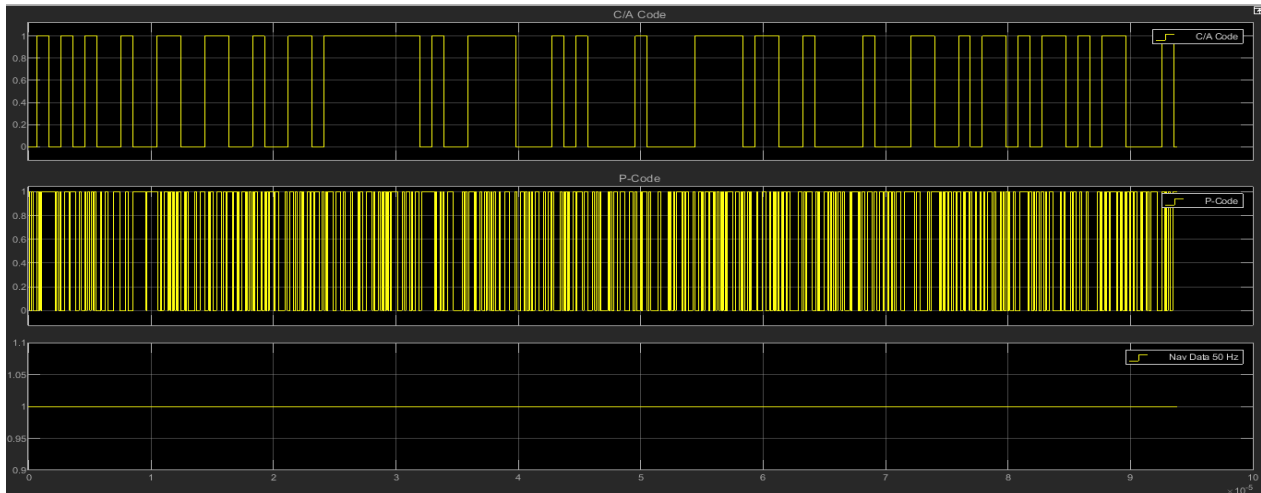

Figure 10: generated C/A code, P code and navigation data

The P-code is faster than the C/A code because of the difference in their chipping rates, which determines how quickly each code sequence is generated.

- The C/A code (Coarse/Acquisition code) has a chipping rate of 1.023 MHz, meaning it produces 1,023 chips per millisecond (1 ms per cycle). This makes it relatively slow compared to the P-code.
- The P-code (Precision code) operates at a much higher chipping rate of 10.23 MHz, producing 10,230 chips per millisecond. This makes the P-code approximately 10 times faster than the C/A code.

This difference is necessary because the P-code is designed for military use and provides finer resolution for more accurate positioning, while the C/A code is used for civilian purposes with lower resolution. The higher frequency of the P-code allows for better precision and security.

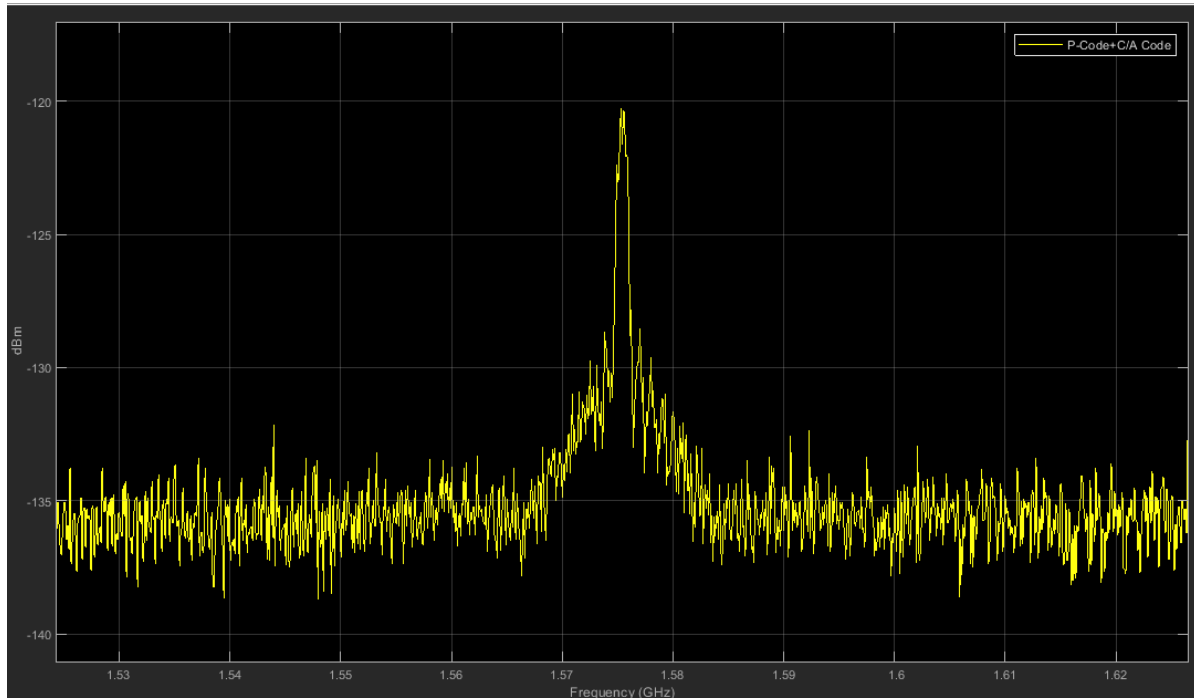

Figure 11: spectrum of generated signal, C/A+P code.

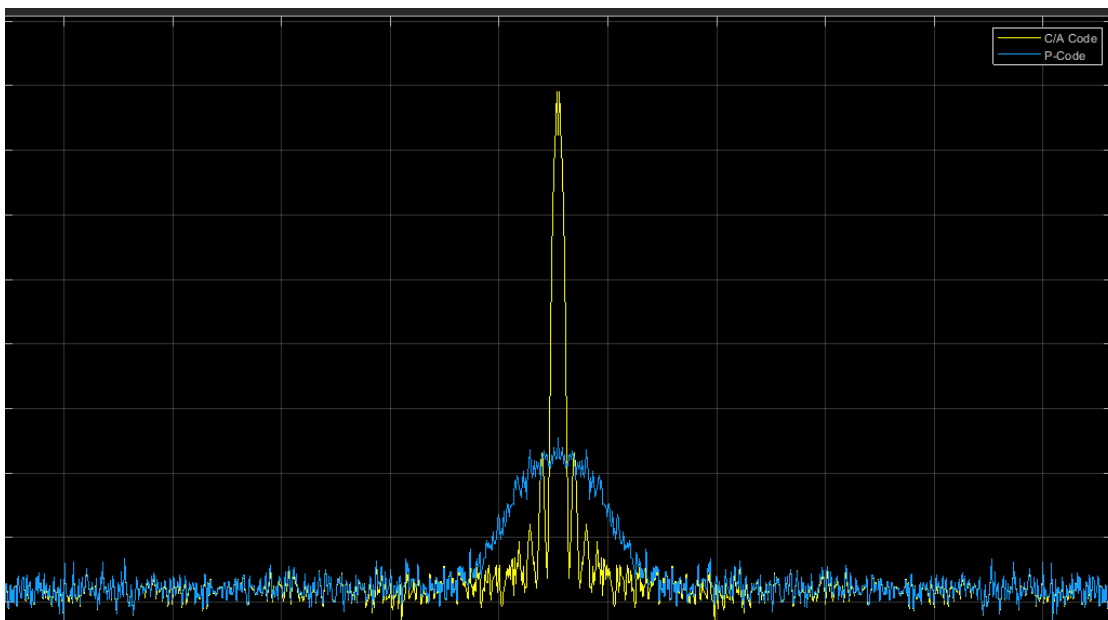

Figure 12: generated C/A code and P code.

The P-code (blue) has a wider bandwidth compared to the C/A code (yellow). This is due to its higher

chipping rate (10.23 MHz for P-code vs. 1.023 MHz for C/A code), meaning the P-code occupies more of the spectrum.

The C/A code has a narrower spread, which is expected because of its lower chipping rate, resulting in less bandwidth.

### 3.3 GALILEO signal generator

The Galileo signal generator design in Simulink focuses on simulating the key signals transmitted by Galileo satellites. This model is used to replicate the signal structure, modulation schemes, and data transmission processes of Galileo, specifically targeting the E1 signals. By using advanced BOC modulation and accurately generating both data and pilot channels, the Simulink model allows for precise simulation of Galileo's Open Service (OS) and Public Regulated Service (PRS) signals.

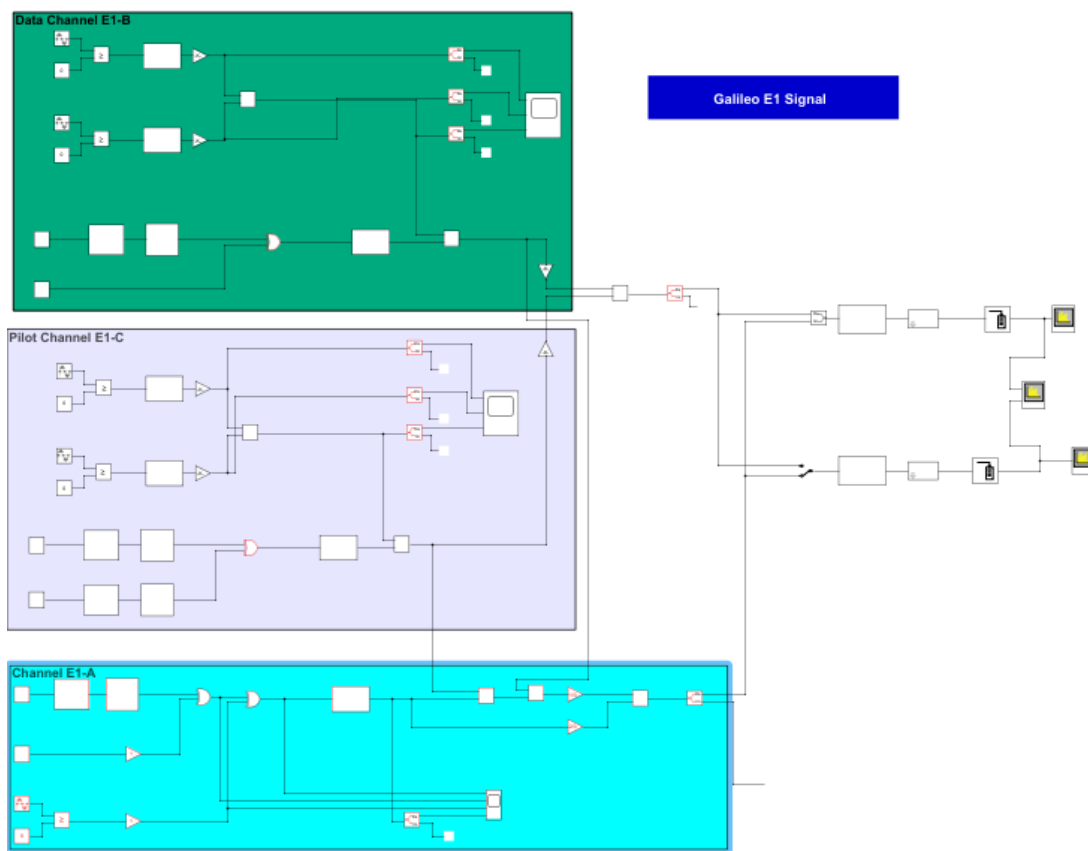

Figure 13: Galileo signal generator scheme.

Data channel:

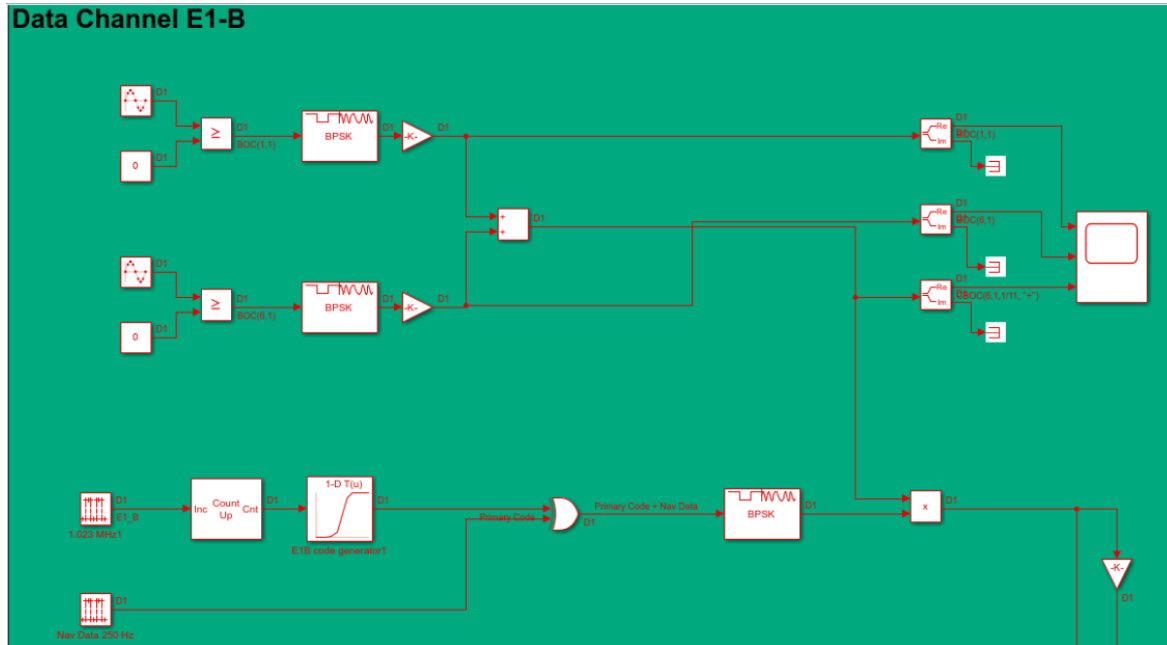

Figure 14: data channel scheme (OS).

Pilot channel:

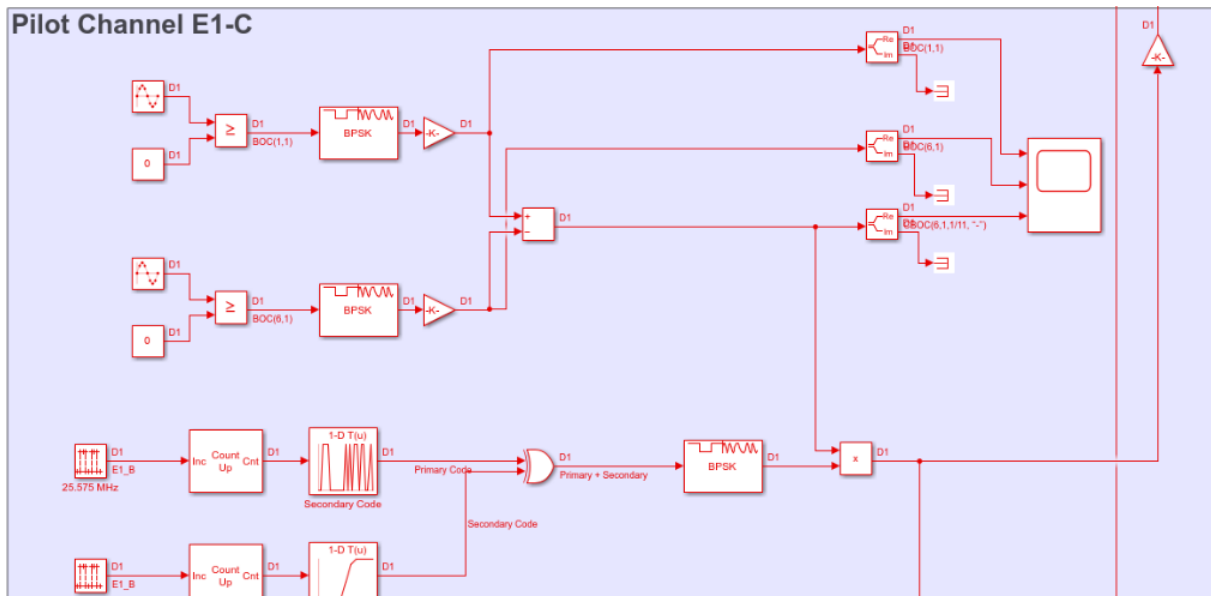

Figure 15: pilot channel scheme.

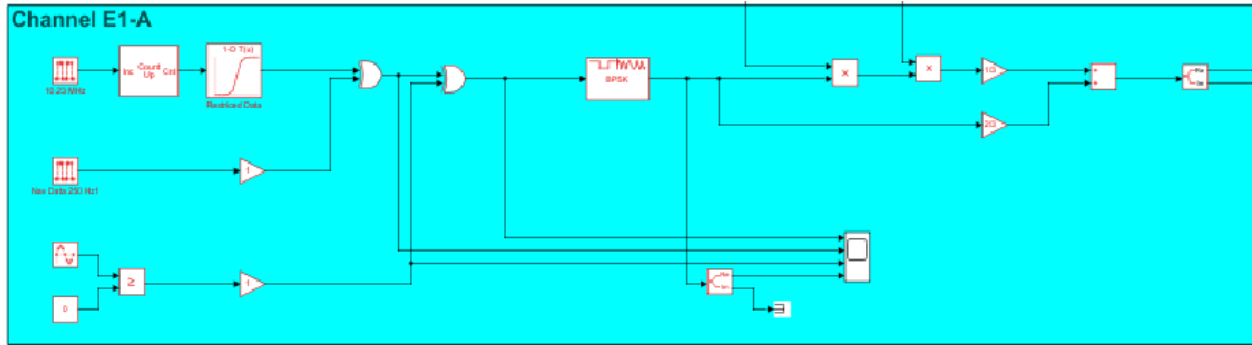

Figure 16: Data channel PRS

The model is divided into three primary sections from left to right:

Signal Generation (Left Side):

- This part is responsible for generating the signals needed for Galileo’s E1 band, which includes the Data Channel (E1-B), Pilot Channel (E1-C), and Restricted Access Channel (E1-A)

Components:

- PRN Code Generator: Each of the channels (E1-A, E1-B, and E1-C) uses a unique Pseudo-Random Noise (PRN) code. These codes are used for spreading the signal in a way that allows for precise satellite positioning.
- BOC Signal Generators: Binary Offset Carrier (BOC) modulation schemes are used for each channel:
  - BOC(1,1) for the Data Channel (E1-B) and Pilot Channel (E1-C).
  - BOC(6,1) for both channels to enhance spectral efficiency.
  - BOC(6,1,1/11) for the Restricted Access Channel (E1-A).
- Random Navigation Bits: These bits represent the actual navigation data, including satellite orbit and timing information, at a 250 Hz rate.

Binary to Bipolar Conversion (Middle Section):

- Binary to Bipolar  $\pm 1$  Conversion: Simulink PRN generators output binary signals (0s and 1s), but the CASM (Composite Adaptive Signal Modulation) algorithm requires these to be converted to bipolar  $\pm 1$  signals.

- This conversion ensures the signal is suitable for further processing in the CASM modulation scheme, which is implemented later in the model.

#### Signal Modulation and Output (Right Side):

- **CASM Modulation:** The Composite Adaptive Signal Modulation (CASM) technique is implemented here to combine the E1-A (Restricted Access), E1-B (Data), and E1-C (Pilot) channels. Each channel carries different information but needs to be multiplexed into a single signal.
- **BPSK Modulation:** The output signals from the BOC generators are BPSK-modulated. In BPSK (Binary Phase Shift Keying), the phase of the signal is shifted according to the binary data, which is essential for GNSS communication.
- **Zero-Order Hold (ZOH):** Used to sample the continuous signal. This step is crucial as the sampling rate (110.5 MHz) ensures that the signal is captured correctly at the intermediate frequency (IF) of about 28 MHz.
  - The Zero-Order Hold block holds the signal constant between sample points, ensuring the signal can be correctly processed or saved.
- **AWGN Block:** An Additive White Gaussian Noise (AWGN) block is used to simulate real-world conditions by adding noise to the signal. This ensures that the model closely mimics real GNSS signal transmission and reception.

#### Output:

- **Final Galileo L1 Signal at L1 Frequency:** The final output is a multiplexed signal consisting of Data (E1-B), Pilot (E1-C), and Restricted Access (E1-A) channels. This composite signal is modulated, sampled, and prepared for further transmission or analysis.

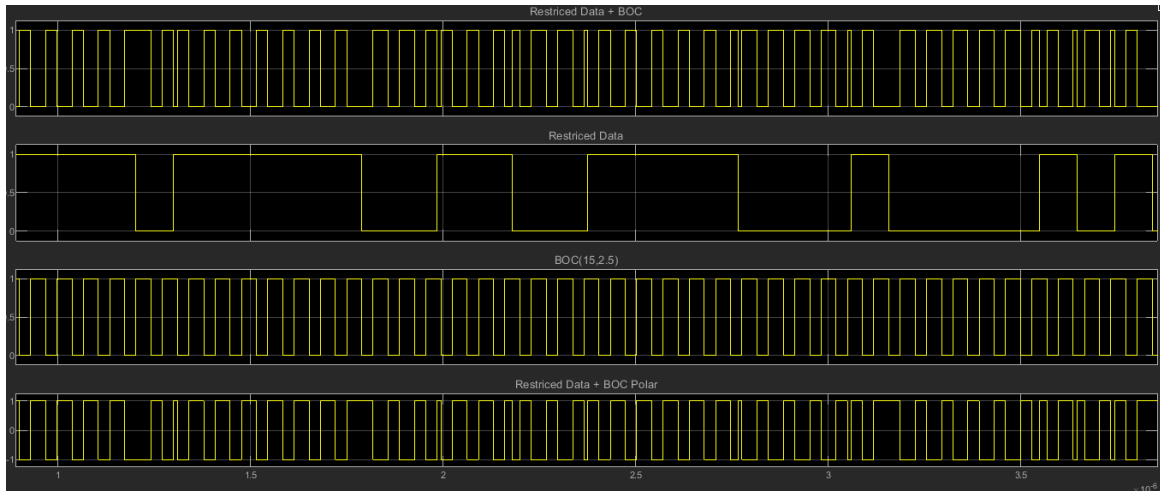

Figure 17: generated BOC(15,2.5) and restricted data.

The BOC (15, 2.5) waveform alternates between 1 and -1 (bipolar), characteristic of Binary Offset Carrier (BOC) modulation. It consists of high-frequency components, creating sharp transitions between states.

Without BOC Modulation: The restricted data alone is simple and binary, with sharp transitions but no intermediate oscillations.

With BOC Modulation: The addition of the BOC signal introduces rapid, high-frequency oscillations to the data signal, resulting in a more complex waveform. This modulation increases the signal's robustness and resistance to interference, which is a key benefit in GNSS applications. The modulation essentially “shapes” the restricted data to be more suitable for transmission over a satellite communication channel by embedding the data in a high-frequency carrier, improving signal integrity.

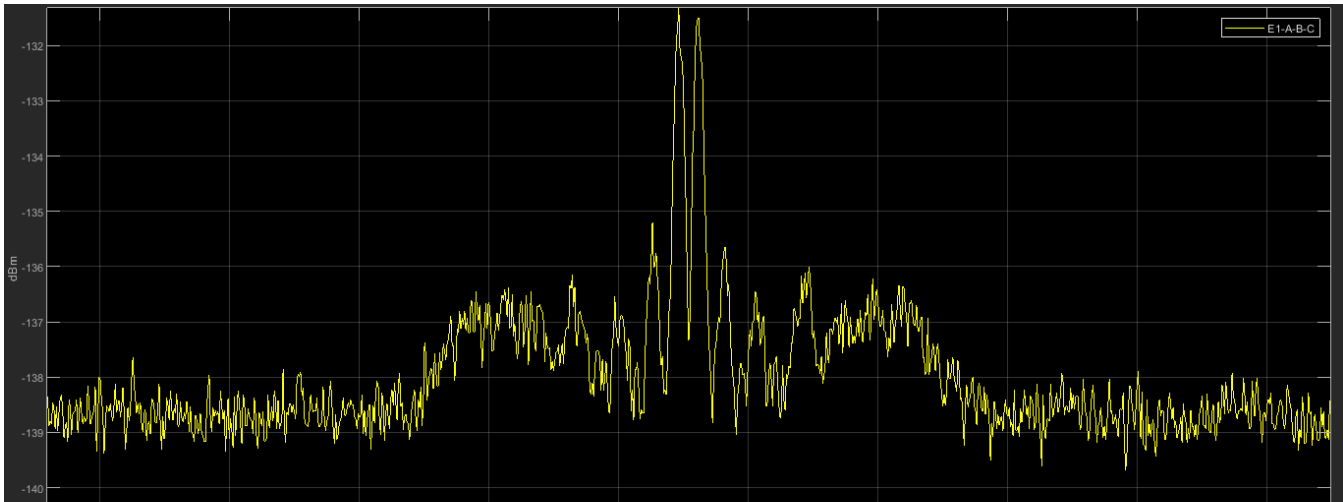

Figure 18: generated Galileo E1 signal (OS)

This plot represents the spectrum of the Galileo E1 Open Service (OS) signal.

The sharp peak at the center corresponds to the primary signal power, while the lower side-lobes are a result of the modulation scheme and spreading codes used in GNSS signals.

The spectrum reflects the BOC modulation used in the Galileo E1 OS signal, which aims to improve performance in terms of signal robustness and interference mitigation.

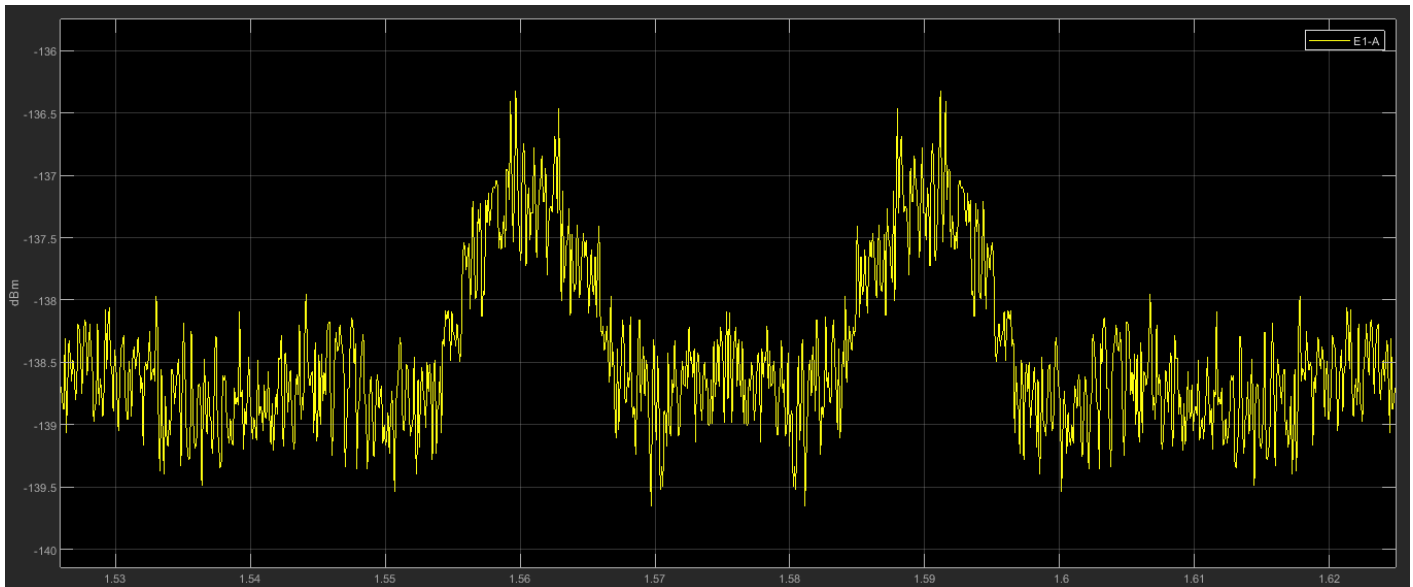

Figure 19: generated Galileo E1-A signal (PRS).

This plot represents the Galileo E1-A signal, used for the PRS (Public Regulated Service).



The spectrum shows a distinct pattern, with multiple side-lobes and a broader central peak compared to the OS signal.

The PRS signal is typically more secure and encrypted, with different characteristics to improve accuracy, robustness, and resistance to jamming and spoofing.

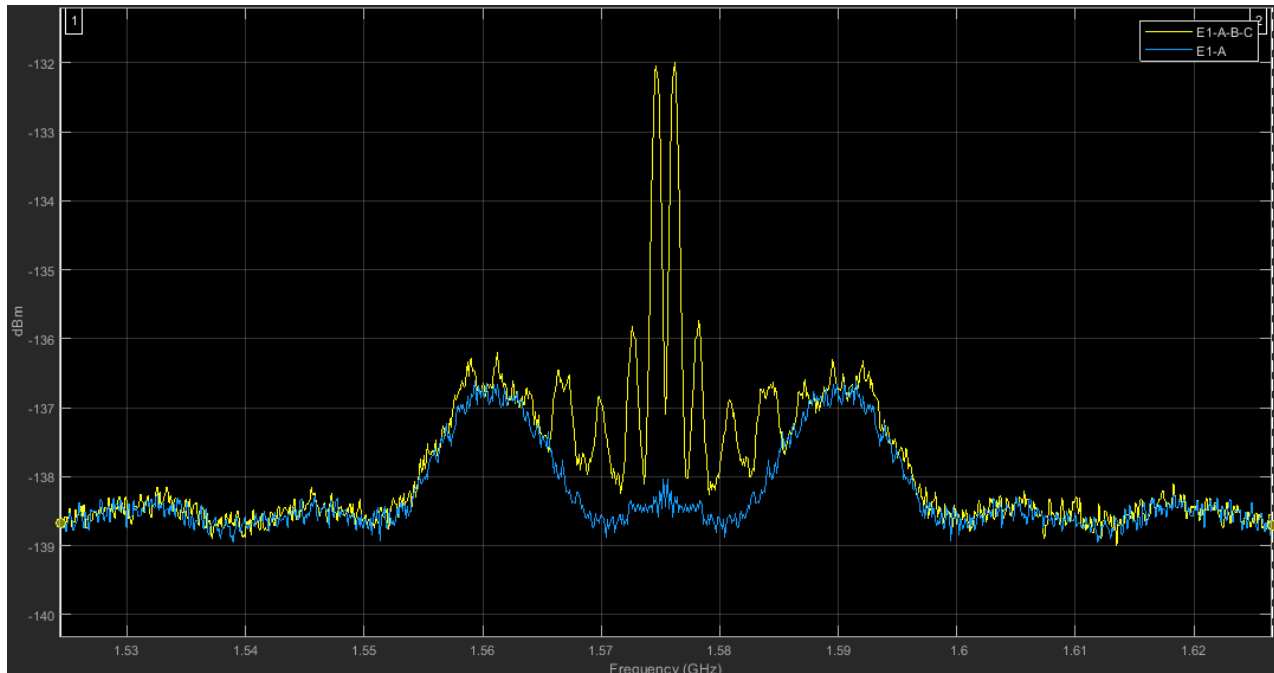

Figure 20: generated E1 signal (OS and PRS).

### 3.4 Signal Differences

This listing only considers Galileo L1 OS and GPS C/A on L1. First the signal differences are analyzed.

**Signal Types** GPS has one public signal and one encrypted, restricted access signal. Galileo will have three signals: two public signals, called Open Service (OS) signals, and one encrypted, called a Public Regulated Service (PRS) signal. Only the OS signals will be considered in the following. One of the OS signals, the data channel, will contain navigation data (ephemerides, almanac, and additional information). The pilot channel will not be modulated with navigation data. It will only be modulated with a short sequence of bits (a secondary code with a code length of 25 chips), which will be repeated all times.

**Spreading Codes** GPS uses a spreading code with 1023 chips, whereas Galileo will use spreading codes with lengths of 4096 chips. The chipping rate is the same for GPS and the Galileo OS signals, 1.023 MHz, but all Galileo codes on L1 are combined with a subcarrier signal (BOC signals). The subcarrier rate is 1.023 MHz for both the L1 OS data and pilot signals. It is expected that a similar type of signal will be used in the modernized GPS (most likely by the GPS III program). The transmitted GPS L1 signals are bandwidth limited to  $20 \times 1.023$  MHz whereas the Galileo L1 signals are limited to  $40 \times 1.023$  MHz the Galileo PRN codes are not yet published. Depending on the final choice of codes, two techniques exist to generate the PRN codes. One is to use linear feedback shift register generators similar to those used in GPS, but with longer registers. The second is to use memory codes that may be pregenerated and stored in memory. Recent Galileo signal developments indicate that additional codes may be used on top of BOC coding to improve signal properties and signal tracking Performance.

### **Data Modulation**

The data modulation process is the same in GPS and Galileo. The BOC signal is multiplied by the data signal (the XOR operation is the equivalent for binary logic signals). The pilot signal is using the same technique to modulate the BOC signal by the secondary code. The navigation data rate on the data channel is 250 Hz. It is likely that the data rate of the secondary code on the pilot channel will be similar to this.

### **3.5 Conclusion**

This chapter outlined the design and functionality of a GNSS signal generator, focusing on the generation of GPS and Galileo signals. The GPS signal generator simulates both C/A and P codes, detailing the processes behind navigation data and P code generation, including their modulation onto a carrier signal. The Galileo signal generator was also discussed, particularly its structure for generating PRN, BOC signals, and navigation messages. This detailed understanding of GNSS signal generators provides a strong foundation for developing systems that can accurately simulate real-world satellite navigation signals for testing and optimization purposes.

## GENERAL CONCLUSION

This thesis successfully addressed the design and implementation of a GNSS signal generator capable of simulating both GPS and Galileo signals within a controlled environment using Simulink. The main goal was to create a flexible and reliable platform for generating and validating GNSS signals, which can be used for testing GNSS receivers without the need for live satellite data.

The work focused on the generation of key GPS signals, including the C/A code, P code, and the integration of navigation data, along with Galileo signals such as the E1 Open Service (OS) and Public Regulated Service (PRS) signals using BOC modulation. Each signal was generated with high precision, closely replicating real-world GNSS signal structures and characteristics. These simulations offer researchers and engineers a valuable tool to develop, test, and improve GNSS receivers in a repeatable and controlled environment.

By successfully implementing this GNSS signal generator, the thesis contributes to the advancement of satellite navigation technology, allowing for more efficient development of GNSS systems. The simulation platform supports ongoing research and innovation in GNSS, providing a critical resource for testing algorithms, enhancing receiver performance, and addressing future challenges in satellite navigation.

## REFERENCES

- [1] Kaplan, E. D., & Hegarty, C. J. (2005). *Understanding GPS: Principles and Applications* (2nd ed.). Artech House.
- [2] Parkinson, B. W., & Spilker, J. J. (1996). *Global Positioning System: Theory and Applications* Volume I. American Institute of Aeronautics and Astronautics.
- [3] GPS.gov (2021). GPS Modernization. <https://www.gps.gov/>
- [4] National Coordination Office for Space-Based Positioning, Navigation, and Timing (NCO). (2021). GPS Control Segment Overview.
- [5] Misra, P., & Enge, P. (2011). *Global Positioning System: Signals, Measurements, and Performance* (2nd ed.). Ganga-Jamuna Press
- [6] European GNSS Agency (GSA). (2021). Galileo Overview. <https://www.euspa.europa.eu/european-space/galileo>
- [7] Betz, J. (2001). Binary Offset Carrier Modulations for Radionavigation. In *Proceedings of the 2001 National Technical Meeting of The Institute of Navigation*.
- [8] G. D. R. Schmidt, J. W. Betz, and S. M. K. N. O’Keefe (2009). The Galileo Signal Design and Its Benefits. *Journal of Navigation*, 62(2), 209-227.
- [9] Montenbruck, O., & Hauschild, A. (2017). *Global Navigation Satellite Systems: A Practical Guide for Users*. Springer.
- [10] European Space Agency (ESA). (2008). Galileo E6 Signal Design and Performance.
- [11] Hofmann-Wellenhof, B., Lichtenegger, H., & Collins, J. (2008). *Global Positioning System: Theory and Practice*. Springer.
- [12] IAESB end of study thesis .(2023). etude et analyse des performances des performances de a detection collective pour es signaux GNSS.
- [13] Kaplan, Elliott D., and Christopher J. Hegarty (eds.). "Understanding GPS: Principles and Applications." Artech House, 2005.

