

الجمهورية الجزائرية الديمقراطية الشعبية
People's Democratic Republic of Algeria

وزارة التعليم العالي والبحث العلمي
Ministry of Higher Education and Scientific Research

جامعة سعد دحلب البليدة
SAAD DAHLAB University of BLIDA

كلية التكنولوجيا
Faculty of Technology
قسم الإلكترونيك
Department of Electronics



Final Report

Domain: Science and Technology

Sector: Electronics

Specialty: Electronics Of Embedded Systems

Accomplished by:

**Belkhelfa Mohammed
&
Aouali Aymen**

THEME

UAV Development Board and Remote Control: Design and Implementation

Supervisor: MR.Y Kabir

Co- Supervisor: Mme.D Naceur

academic year 2023-2024

Acknowledgements

First and foremost, we are profoundly grateful to Allah for His countless blessings and guidance throughout our journey. Without His wisdom and grace, this work would not have been possible.

We would like to express our deepest gratitude to our families for their unwavering support and encouragement. Their love and patience have been a constant source of strength and inspiration.

A special thank you to Mr. Y Kabir, our supervisor, for his invaluable guidance, the provision of necessary materials and components, and his unwavering support. His expertise and dedication have been instrumental in the completion of this thesis.

We extend our heartfelt thanks to Mme.D Naceur for her mental support and her assistance in the preparation of the report. Her encouragement and advice have been greatly appreciated.

We sincerely thank Mr. Guessoum and Mr. Bounemri for accepting our theme and serving as members of the jury. We are grateful for their time and dedication to our work.

We are also grateful to the Doofas Company and their team for guiding us in the making of our PCBs and sharing their extensive experience in this field. Their collaboration and insights have been crucial to our project's success.

Lastly, we wish to acknowledge all our friends who have given their best wishes and support throughout this journey. Your encouragement and kindness have meant the world to us.

Thank you all for being a part of this endeavor and for your contributions to its success.

Dedication:

Mohammed

- Above all, I am profoundly thankful to Allah for His blessings and guidance throughout this journey.

My deepest gratitude goes to my family for their unwavering support and encouragement. Their love and patience have been my enduring source of strength.

I am especially grateful to Mr. Y Kabir, my supervisor, for his invaluable guidance and support. His expertise has been essential in completing this thesis.

Sincere thanks to Mme. D Naceur for her mental support and assistance with the report. Her encouragement and advice have been greatly appreciated.

I am thankful to the Doofas Company, especially Mr. Oussama Assaous, Mr. Lafri Abdelmoumen, and Mr. Rebika S, for their guidance in developing my PCBs and for sharing their extensive knowledge. Their collaboration has been crucial to the success of my project.

Lastly, I acknowledge all my friends for their support and good wishes throughout this journey. Your encouragement and kindness have been invaluable to me.

Thank you all for contributing to this endeavor's success.

Aymen

- I salute my parents and thank them for their endeavors in raising me and their concern for me, and their contribution in this project as well as all previous projects.

I salute my family who are always by my side. I salute my friends who always encourage me.

I pay a special tribute to our professors from whom we have learn a lot throughout our university career, especially Mrs.D.Naceur and Mr.Y.Kabir for embracing our work and providing us with what we needed.

I thank Mr.A.LARFI who always motivates us and provides us with a helping hand to complete the project, to Mr.Oussama, the professional PCB designer who work at DOOFAS Company for his Patience and helping us solve the crystal selection problem, and special thanks to my brother Rayan the distinguished.

ملخص:

تثبيت الطائرات بدون طيار هو عملية معقدة تتضمن عدة نقاط مهمة، وهي مراقبة البطارية، قراءة معلومات المستشعرات، الخوارزميات التحكمية، نقل البيانات اللاسلكي، وضبط سرعة المحركات. لمواجهة هذا التحدي، قمنا بتصميم وتنفيذ ثلاثة وحدات تجمع بين كل هذه الخصائص: وحدة التحكم في الطيران، وحدة توزيع الطاقة ومراقبة البطارية، وأخيراً وحدة التحكم عن بعد.

كلمات المفاتيح:

طائرة بدون طيار، وحدة تحكم في الطيران، وحدة تحكم في الطيران، جهاز تحكم عن بعد، توزيع الطاقة ومراقبة البطارية، فلتر كالمان، وحدة تحكم دقيقة، لوحة دوائر، التوافق الكهرومغناطيسي، وحدة تحكم PID.

Résumé :

La stabilisation des drones est un processus complexe, regroupant plusieurs points importants, à savoir la surveillance de la batterie, la lecture des informations des capteurs, l'algorithmique de contrôle, la transmission des données sans fils et l'ajustement de la vitesse des moteurs.

Pour ce défi, nous avons conçu et réalisé trois modules qui combinent toutes ces caractéristiques, le module contrôleur de vol, celui du distributeur d'énergie et de surveillance de la batterie, et enfin celui de la commande à distance.

Mots clés :

Drone, contrôleur de vol, télécommande, distribution d'énergie et surveillance de la batterie, filtre KALMAN, microcontrôleur, circuit imprimé, compatibilité électromagnétique, contrôleur PID.

Abstract:

Drone stabilization is a complex process that involves several important points, including battery monitoring, sensor information reading, control algorithm, wireless data transmission, and motor speed adjustment. For this challenge, we have designed and implemented three modules that combine all these features: the flight controller module, the power distribution and battery monitoring module, and finally, the remote-control module.

Keywords:

Drone, flight controller, remote control, power distribution and battery monitoring, KALMAN filter, micro-controller, circuit board, electromagnetic compatibility, PID controller.

Table of Contents

General Introduction:	1
chapter I	3
what a drone and its history	3
I.1 Introduction.....	4
I.2 The definition of a drone.....	4
I.3 history of drones	4
I.3.1 The earliest breakthroughs	4
I.3.2 The first military drones	5
I.3.3 FAA creates commercial drone permits	6
I.3.4 the Parrot AR Drone	6
I.3.5 Drones get smarter	7
I.4 Components of a Drone	7
I.4.1 Frame.....	8
I.4.2 Motor and Propellers	8
I.4.3 Flight Controller	8
I.4.4 Battery	9
I.4.5 Sensors	9
I.4.6 Camera and Gimbal.....	10
I.4.7 Transmitter and Receiver.....	10
I.5 Uses of Drones	11
I.5.1 Aerial Photography and Videography	11
I.5.2 Agriculture.....	12
I.5.3 Delivery Services	12
I.5.4 Emergency Response.....	12
I.6 Benefits and Drawbacks of Drones	13
I.6.1 Benefits	13
I.6.2 Drawbacks	14
I.7 Future of Drones.....	14
I.7.1 Autonomous Operation	14
I.7.2 Urban Air Mobility	14
I.7.3 AI-Powered Drones	15
I.7.4 Collaborative Swarms	15
I.8 Conclusion	15

chapter II	17
State of the Art	17
II.1 Introduction	18
II.2 The works that have created buzz recently in UAV field	18
II.2.1 Replace propellers by ion propulsion	18
II.2.2 Hybrid drones	19
II.2.2.1 Aerial-aquatic drones (UAV-UUV)	19
II.2.2.2 Aerial-terrestrial drones (UAV-UGV)	21
II.3 Open-source flight controller and software	23
II.3.1 Open-source flight controllers (OSH)	23
II.3.1.1 FPGA based platform	23
II.3.1.2 ARM based platform	24
II.3.1.3 ATMEL based platform	27
II.3.1.4 Raspberry based platform	27
II.3.2 Open-source software (OSS) and simulation platforms	28
II.3.2.1 Open-source platforms	28
II.3.2.2 Open-source simulation platform	31
II.4 Conclusion	33
chapter III	34
Conceptual Study	34
III.1 Introduction	35
III.2 Importance of Selecting the Right Microcontroller for a Drone Flight Controller	35
III.3 Criteria for Selecting the STM32F407VET6 Microcontroller	35
III.3.1 Processing Power	35
III.3.2 I/O Capabilities	35
III.3.3 Power Consumption	36
III.4 Process of Selecting Other Components	36
III.4.1 Sensors	36
III.4.1.1 SPL06-001 (Barometric Pressure Sensor)	37
III.4.1.2 ICM-20689 (Inertial Measurement Unit)	37
III.4.1.3 MPU6500 (Inertial Measurement Unit)	38
III.4.1.4 BM1422AGMV-ZE2 (Magnetometer)	38
III.4.1.5 NEO-6M (GPS Module)	39

III.4.2	Actuators	40
III.4.2.1	Brushless DC Motors (A2212/6 - 2200Kv)	40
III.4.2.2	Electronic Speed Controllers (ESC 30A)	40
III.4.3	Communication Modules.....	41
III.4.3.1	nRF24L01-PA-LNA Module	41
III.5	Conclusion	42
chapter IV	43
Implementation of Drone Systems through PCB Design	43
IV.1	Introduction	44
IV.2	Design Principles for Drone PCBs.....	44
IV.2.1	Overview of PCB Design.....	44
IV.2.1.1	Assembly capabilities	44
IV.2.1.2	Minimum Clearance.....	45
IV.2.1.3	Drill/Hole Size	46
IV.2.1.4	Solder Mask	48
IV.2.1.5	PCB Specifications	49
IV.2.1.6	Minimum Trace Width and Spacing	50
IV.2.2	Design Software Tools	51
IV.2.2.1	EasyEDA.....	51
IV.2.2.2	JLCPCB.....	52
IV.2.3	Design Requirements.....	53
IV.2.3.1	Flight Controller PCB.....	53
IV.2.3.2	Remote Control PCB.....	54
IV.2.3.3	Power Distribution PCB.....	54
IV.3	Holistic Drone System Schematic Design.....	54
IV.3.1	Flight Controller schematic Design.....	54
IV.3.1.1	Circuit Design	54
IV.3.1.2	PCB Layout.....	59
IV.3.2	Remote Control schematic Design	60
IV.3.2.1	Circuit Design	60
IV.3.2.2	Communication Modules	61
IV.3.2.3	Power Supply	62
IV.3.2.4	User Interface Components.....	62

IV. 3.2.5	PCB Layout and Fabrication.....	64
IV. 3.2.6	Challenges Faced During Fabrication	64
IV. 3.3	Power Distribution System Schematic Design.....	65
IV.3.3.1	Circuit Design	65
IV. 3.4	Detailed Diagrams of Schematics.....	68
IV.3.4.1	Flight Controller	68
IV.3.4.2	Remote Control.....	68
IV.3.4.3	Power Distribution System.....	69
IV. 3.5	Final Pcb's Design	70
IV.3.5.1	Pcb Flight controller	70
IV.3.5.2	Pcb Remote control	71
IV.3.5.3	Pcb Power distribution.....	72
IV.4	Programming language and tools.....	72
IV.5	Accessing to sensors, actuators, and communication ICs.....	74
IV.5.1	SPI.....	74
IV.5.2	USART	76
IV.5.3	TIMERS	77
IV.5.4	ADC	77
IV.5.5	USB	78
IV.5.6	I2C	78
IV.6	Software development planning	79
IV.6.1	Testing each circuit independently.....	79
IV.6.2	Control algorithms:	80
IV.7	Conclusion	85
	General conclusion:	86
	 Bibliography:.....	 88
	 Annex:	 91
1.	Annex: Technical Specifications of Components.....	92
2.	Annex Illustrations	94

List of acronyms and abbreviations

- **UAV (Unmanned Aerial Vehicle)**
- **RC (Radio-Controlled)**
- **FAA (Federal Aviation Administration)**
- **CES (Consumer Electronics Show)**
- **GPS (Global Positioning System)**
- **IMU (Inertial Measurement Unit)**
- **SPI (Serial Peripheral Interface)**
- **IC (Inter-Integrated Circuit)**
- **UART (Universal Asynchronous Receiver-Transmitter)**
- **CAN (Controller Area Network)**
- **ADC (Analog-to-Digital Converter)**
- **PWM (Pulse Width Modulation)**
- **LiPo (Lithium Polymer)**
- **OLED (Organic Light Emitting Diode)**
- **MCU (Microcontroller Unit)**
- **FPGA (Field-Programmable Gate Array)**
- **SoC (System on Chip)**
- **ROS (Robot Operating System)**
- **VFR (Visual Flight Rules)**
- **IFR (Instrument Flight Rules)**
- **SWD (Serial Wire Debug)**
- **JTAG (Joint Test Action Group)**
- **IDE (Integrated Development Environment)**
- **HAL (Hardware Abstraction Layer)**
- **DMA (Direct Memory Access)**
- **CRC (Cyclic Redundancy Check)**
- **PCB (Printed Circuit Board)**
- **eVTOL (Electric Vertical Takeoff and Landing)**
- **MMWAVE (Millimeter Wave)**
- **Lidar (Light Detection and Ranging)**
- **PX4 (Pixhawk Open-Source Flight Control Software)**
- **GCS (Ground Control Station)**
- **SAR (Successive Approximation Register)**
- **TI (Texas Instruments)**

- **DFU (Direct Firmware Update)**
- **ENMA (National Marine Electronics Association)**

List of Figures

Figure I. 1 The world's first quadcopter	5
Figure I. 2 the Ruston Proctor Aerial Target	5
Figure I. 3 The Federal Aviation Administration	6
Figure I. 4 AR Drone prototype	7
Figure I. 5 DJI Phantom 4	7
Figure I. 6 Various drone frames	8
Figure I. 7 Motors and Propellers	8
Figure I. 8 Different flight controllers	9
Figure I. 9 battery	9
Figure I. 10 Various sensors used in drones	10
Figure I. 11 Camera and Gimbal	10
Figure I. 12 Transmitter and Receiver	11
Figure I. 13 Aerial Photography and Videography Using Drones	11
Figure I. 14 Agricultural Applications of Drones	12
Figure I. 15 Drones in Delivery Services	12
Figure I. 16 Emergency Response with Drones	13
Figure II. 1 Silent Ventus Hybrid Drone	19
Figure II. 2 TJ-Fling Fish	20
Figure II. 3 Aerial-Aquatic Hitchhiking Robot	20
Figure II. 4 Dipper Fixed-Wing Drone by ETH Zurich	21
Figure II. 5 Rollocopter Hybrid Aerial and Terrestrial Drone	22
Figure II. 6 HUUVER Hybrid UAV-UGV	22
Figure II. 7 OCPOC (Octagonal Pilot on Chip) Flight Controller	23
Figure II. 8 PHENIX PRO Reconfigurable Flight Controller	24
Figure II. 9 PIXHAWK Flight controller	24
Figure II. 10 SPARKY Flight controller	25
Figure II. 11 PAPERAZZI CHIMERA Open-Source Flight Controller by ENAC	25
Figure II. 12 ATOM & CC3D Flight Controllers by OpenPilot	26
Figure II. 13 FLYMAPLE Quadcopter Controller Board	26
Figure II. 14 ArduPilot Arduino Mega-Based Autopilot System	27
Figure II. 15 PXM MINI Autopilot Shield	27
Figure II. 16 ERLE-BRAIN 3	28
Figure II. 17 ArduPilot Mission Planner Interface	29
Figure II. 18 PX4 Ground Control Interface	29

Figure II. 19 LibrePilot/OpenPilot Interface	30
Figure II. 20 Multiwii Interface	30
Figure II. 21 JmavSim (Java Micro Air Vehicle Simulator)	31
Figure II. 22 Gazebo Simulator Interface	32
Figure II. 23 Morse Simulator Interface	32
Figure II. 24 AirSim Simulator Interface	33
Figure III. 1 STM32F407VET6 Microcontroller	36
Figure III. 2 SPL06-001 (Barometric Pressure Sensor)	37
Figure III. 3 ICM-20689 (Inertial Measurement Unit)	38
Figure III. 4 MPU6500 (Inertial Measurement Unit)	38
Figure III. 5 BM1422AGMV-ZE2 (Magnetometer)	39
Figure III. 6 NEO-6M (GPS Module)	39
Figure III. 7 Brushless DC Motors (A2212/6 - 2200Kv)	40
Figure III. 8 Electronic Speed Controllers (ESC 30A)	41
Figure III. 9 nRF24L01-PA-LNA Module	42
Figure IV. 1 Assembly capabilities	45
Figure IV. 2 Minimum Clearance	46
Figure IV. 3 Drill/Hole Size	48
Figure IV. 4 Solder Mask	49
Figure IV. 5 PCB Specifications	50
Figure IV. 6 Minimum Trace Width and Spacing	51
Figure IV. 7 EasyEDA Homepage	51
Figure IV. 8 EasyEDA PCB Design Workspace	52
Figure IV. 9 JLCPCB Homepage	53
Figure IV. 10 STM32F407VET6 Microcontroller Schematic Diagram	55
Figure IV. 11 MPU6500 Sensor Schematic Diagram	55
Figure IV. 12 ICM-20689 Gyro/Acc Schematic Diagram	56
Figure IV. 13 SPL06-001 Barometric Pressure Sensor Schematic Diagram	56
Figure IV. 14 BM1422AGMV Magnetometer Schematic Diagram	57
Figure IV. 15 GPS Module Schematic Diagram	57
Figure IV. 16 nRF24L01+ Module Schematic Diagram	57
Figure IV. 17 USB Interface Circuit Schematic Diagram	58
Figure IV. 18 ST-Link SWD Interface Schematic Diagram	58
Figure IV. 19 CAN nterface Schematic Diagram	59

Figure IV. 20 Voltage Regulator with LED Indicator Schematic Diagram	59
Figure IV. 21 STM32F103C8T6 Microcontroller Schematic Diagram	61
Figure IV. 22 nRF24L01+ PA+LNA Module Schematic Diagram.....	62
Figure IV. 23 5V to 3.3V Voltage Regulator Schematic Diagram	62
Figure IV. 24 buttons Schematic Diagram	63
Figure IV. 25 Joystick Interface Schematic Diagram.....	63
Figure IV. 26 OLED Display Interface Schematic Diagram.....	64
Figure IV. 27 Buck Converter Schematic Diagram.....	65
Figure IV. 28 3.3V LDO Regulator Schematic Diagram.....	66
Figure IV. 29 Shunt Current Sensor Circuit Schematic Diagram	67
Figure IV. 30 Voltage Sensing Circuit Schematic Diagram	67
Figure IV. 31 Flight Controller Diagram.....	68
Figure IV. 32 Remote control Diagram	69
Figure IV. 33 Power distribution Diagram.....	69
Figure IV. 34 2D Pcb flight Controller Top and Bottom View	70
Figure IV. 35 3D Pcb flight controller Top And Bottom View	70
Figure IV. 36 2D Pcb Remote control Top And Bottom View	71
Figure IV. 37 3D Pcb Remote control Top And Bottom View	71
Figure IV. 38 2D Pcb Power distribution Top And Bottom View	72
Figure IV. 39 3D Pcb Power distribution Top And Bottom View	72
Figure IV. 40 component testing methodology	80
Figure IV. 41 direct motors control software flow chart for remote control and flight controller	81
Figure IV. 42 angular velocity control loop flow chart.....	81
Figure IV. 43 angular velocity mode software flow chart for remote control and flight controller.....	82
Figure IV. 44 angular control loop flow chart.....	83
Figure IV. 45 angular mode software flow chart for remote control and flight controller.....	83
Figure IV. 46 angular mode and altitude velocity mode control loop flow chart.....	84
Figure IV. 47 angular mode and altitude velocity mode software flow chart for remote control and flight controller.....	84

General Introduction:

Flight controllers are one of the most what drones manufactures focus on due to its important in UAV control, it ensure stabilization, data wireless transmission and battery monitoring. Note that designing such units is closer to embedded system specialty, because of the huge use of electronics (PCB design, power electronic) and embedded programing inside it. Therefore, we decide to raise the bar of challenge and choose this topic to apply what we have learn throughout our university career.

The reasons that led us to choose this theme are as follows:

The development of flight controllers is directly related to the field of electronics, particularly with regard to embedded systems, including the design of PCB, power electronics, working with various types of intelligent sensors, and mastery of communication protocols such as USB, SPI, i2c and UART, SPI, i2c, UART, as well as mastering the programming of STM32 microcontrollers, creating wireless communication protocols based on the NRF24L01 circuit, reading the values of ADCs, learning to communicate with the SSD1603 driver for OLEDs, and developing programming skills using the HAL library.

A number of studies have been carried out into the design of UAV flight controllers, including one by Meier Lorenz, a Swiss researcher at the University of Zurich, entitled "PIXHAWK a Micro Aerial Vehicle Design for Autonomous Flight using On-board Computer Vision", which produced with his team a flight controller that now has a large market share.

In the context of this study, we have developed the following problematic:

How we can design a system that control a drone by remote control?

In order to answer this question, we divided the overarching problematic into a micro-problematic as fallowing:

- What is drones and what are used for?
- What are the main components of drone?
- Which flight controllers are open source?
- There is open-source software for drone simulation and configuration?
- Which sensors and actuators we use?

- Which microcontroller and communication module we should use?
- What are the necessary units needed by the flight controller?
- Which protocol we need to use for wireless communication between flight controller and the remote control?
- How to change drone flight mode by the remote control?

By taking into account, the problems mentioned above as well as the literature on the topic we postulate that it is possible to build a system, which control drones by remote control.

Considering the aforementioned challenges and the existing literature on the subject, we propose that it is feasible to develop a system capable of controlling drones via remote control. The primary goal of this research is to design a reliable system for remotely managing UAVs, focusing on creating motherboards that adhere to the ELECTRO-MAGNETIC COMPATIBILITY STANDARD as per STMicroelectronics' guidelines. This involves designing PCBs with a specified number of layers to minimize signal noise. The project aims to produce three printed circuit boards: a flight controller, a remote control, and a power distribution board.

The success of this end-of-study project could be envisaged as part of the creation of a start-up aimed at marketing flight controllers.

To make this project we have divided it into four chapters, a conclusion and bibliography. In the first, we will define what it is a drone and its history, as well as we take a look on its entire components such as sensors, batteries, remote control, and motors, also, the uses of drones.

In a second chapter, we will show what are the drone projects and researches that make buzz around the world. In addition, we give a general look on open-source flight controllers and open-source software like drone's configuration application and simulators.

In the third chapter. We will describe the characteristics and the reasons for choosing sensors like MPU6500. Communication module such as NRF24L01, and especially the microcontroller because of its important role to making a powerful and fast system.

In the fourth chapter. We will proceed to a detailed description of the schematic and layout of the printed circuit boards, as well as the JLCPCB design rules to which we must pay attention. In addition, we will focus on the different methods to stabilize drones.

chapter I

what a drone and its history

I.1 Introduction

Drones, or unmanned aerial vehicles (UAVs), represent a fascinating intersection of technology and innovation. In this chapter, we will embark on an exploration of drones, looking at the different aspects that define their existence and usefulness.

We'll start by understanding what a drone is, highlighting its main features and functions. Then we'll trace the history of drones, from the first breakthroughs to the milestones that have shaped their development.

Next, we'll dissect the essential components that make up a drone, giving an overview of the technology that powers these remarkable machines. We'll also explore the various uses of drones in different industries, highlighting their versatility and the revolutionary impact they've had.

In addition, we will look at the pros and cons of using drones, balancing their benefits against the challenges they pose. Finally, we'll look at the future of drones, considering the potential advances and emerging trends that will shape their evolution.

By the end of this chapter, you will have a thorough understanding of drones, their capabilities and their importance in current and future contexts.

I.2 The definition of a drone

A drone, also known as an unmanned aerial vehicle (UAV), is an aircraft that does not require a human pilot to fly it. Control can be performed autonomously by a computer or remotely by a ground operator. Drones come in many shapes and sizes, from small handheld devices to larger, more complex aircraft. Originally designed for military purposes, they have experienced rapid development and advancement in various civilian fields such as aerial photography, search and rescue operations, crop protection, animal husbandry, etc. [1]

I.3 history of drones

I.3.1 The earliest breakthroughs

In 1907, The world's first quadcopter, Figure I.1, was created by inventor brothers Jacques and Louis Bréguet, working with controversial Nobel Prize winner Professor Charles Richet. While undoubtedly exciting, it had some big limitations: being unsteerable, requiring four men to steady

it, and — in its first flight — lifting just two feet off the ground. But it did innovate the quadcopter form factor we have today [2].

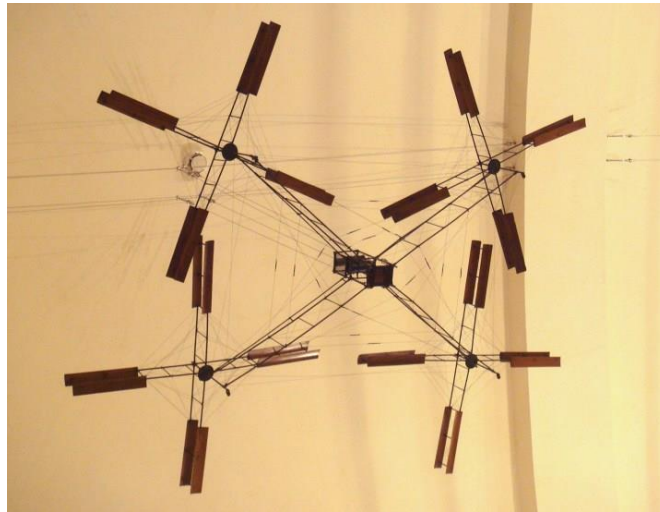

Figure I. 1 The world's first quadcopter[2].

I.3.2 The first military drones

In 1917, the Ruston Proctor Aerial Target, Figure I.2, became the first unmanned winged aircraft in history, launching just 16 years after the Wright brothers' pioneering flight of the Kitty Hawk. It was a radio-controlled, unmanned aircraft based on inventor Nikola Tesla's RC technology. The Aerial Target's purpose was to act as a flying bomb that could be dropped on enemies. Despite promising demonstrations, the AT was never ultimately used in a combat scenario. However, it paved the way for similar projects, such as the amazing Kettering Bug – and paved the way for today's military drones.

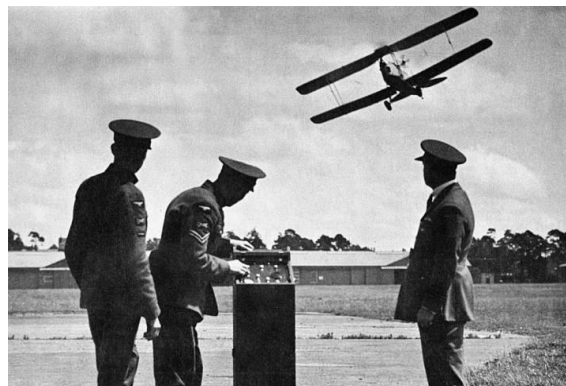

Figure I. 2 the Ruston Proctor Aerial Target[2].

I.3.3 FAA creates commercial drone permits

Recognizing the potential of non-military and non-consumer drones, the FAA, Figure I.3 issued the first commercial drone permits in 2006. These permits lifted some of the restrictions on recreational consumer drones. In doing so, they opened up new opportunities for businesses or professionals who wanted to use drones in a variety of commercial activities. Initially, there were virtually no commercial drone permits in demand. However, that number quickly grew.



Figure I. 3 The Federal Aviation Administration[2].

I.3.4 the Parrot AR Drone

In 2010, The French company Parrot released their Parrot AR Drone, the first ready-to-fly drone which can be controlled entirely via Wi-Fi, using a smartphone. The drone was almost immediately successful, both critically and commercially, receiving the 2010 CES Innovations award for Electronic Gaming Hardware, and selling upwards of half a million units. The company's AR Drone 2.0 further improved on the formula with an easier piloting system, making it easier for newcomers to pick-up-and-play.



Figure I. 4 AR Drone prototype[2].

I.3.5 Drones get smarter

in 2016, Already one of the best drone makers on the marketplace, DJI's Phantom 4 Figure 1.5 introduced smart computer vision and machine learning technology. This allowed it to avoid obstacles and intelligently track (and photograph) people [3], animals, or objects — rather than being limited to following a GPS signal. The resulting UAV was a major milestone for drone photography and consumer drones in general.



Figure I. 5 DJI Phantom 4[2].

I.4 Components of a Drone

In order to understand how drones work, it's important to become familiar with their various components, and there are a few essential parts of a drone [4]:

I.4.1 Frame: The frame forms the structure of the drone and provides the necessary support for all other components. Frames are typically made of lightweight materials such as carbon fiber or aluminum to maintain durability while minimizing weight.



Figure I. 6 Various drone frames[4]

I.4.2 Motor and Propellers: Drones are equipped with multiple motors and propellers that generate lift and propulsion. The number of motors and propellers depends on the type of drone. They work together to provide stability and control during flight.



Figure I. 7 Motors and Propellers[4]

I.4.3 Flight Controller: The flight controller is the drone's brain. It processes data from various sensors and provides commands to the motors, determining the drone's flight path, stability, and response to control inputs.

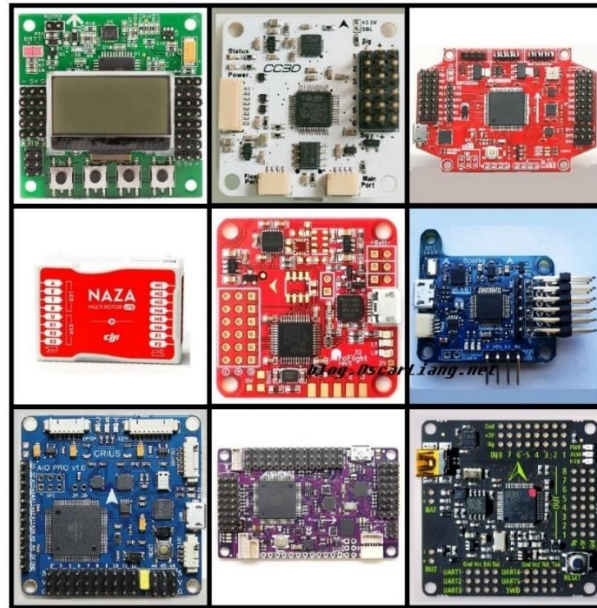

Figure I. 8 Different flight controllers[4]

I.4.4 Battery: Drones are powered by a rechargeable battery, usually a lithium polymer (LiPo) battery. The battery supplies the necessary electrical energy to the motors, flight controller, and other components to keep the drone in flight.



Figure I. 9 battery[4]

I.4.5 Sensors: Drones are equipped with a variety of sensors that provide vital information to the flight controller. These include accelerometers, gyroscopes, magnetometers, barometers, and GPS modules. Sensors help the drone maintain stability, altitude, position, and orientation.

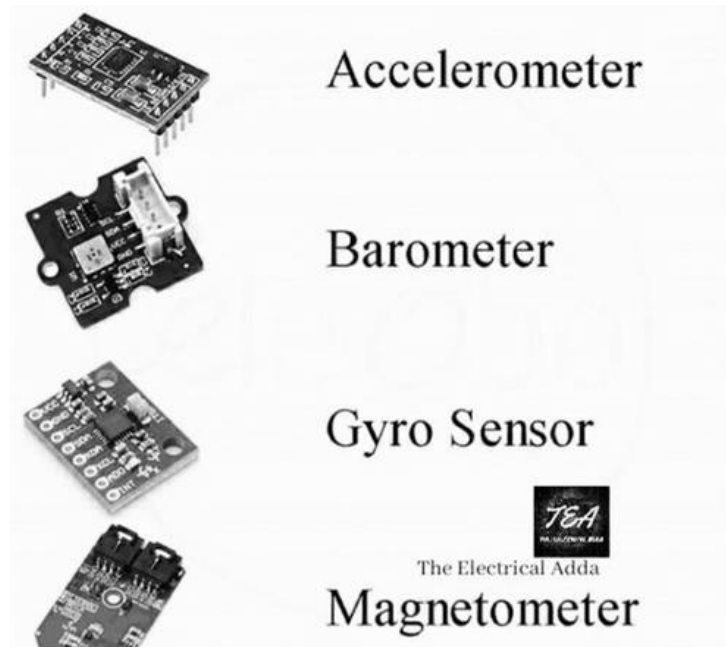

Figure I. 10 Various sensors used in drones[4]

I.4.6 Camera and Gimbal: Many drones are equipped with cameras to capture aerial photos and videos. The camera is mounted on a gimbal, a device that stabilizes the camera and allows it to maintain a steady position even during the drone’s movements. This enables the capture of high-quality, shake-free footage.



Figure I. 11 Camera and Gimbal[4]

I.4.7 Transmitter and Receiver: Drones are controlled remotely using a transmitter and receiver system. The transmitter, held by the pilot, sends control signals to the drone’s receiver, which interprets the commands and relays them to the flight controller, allowing the pilot to maneuver the drone.



Figure I. 12 Transmitter and Receiver[4]

make up a drone. The integration and functionality of these components, combined with advanced software and algorithms, allow drones to perform a wide range of tasks and applications. Understanding how these components work together is crucial for drone operators and enthusiasts interested in getting the most out of their drones.

I.5 Uses of Drones

Drones have a wide range of applications across industries and are proving to be versatile tools that can revolutionize different fields. Here's a look at some of the most important uses of drones [5]:

I.5.1 Aerial Photography and Videography: Drones are widely used in the photography and filmmaking industry to capture stunning aerial shots and videos. With their ability to reach high altitudes and maneuver through tight spaces, drones provide a unique perspective that was once only possible with expensive equipment like helicopters.

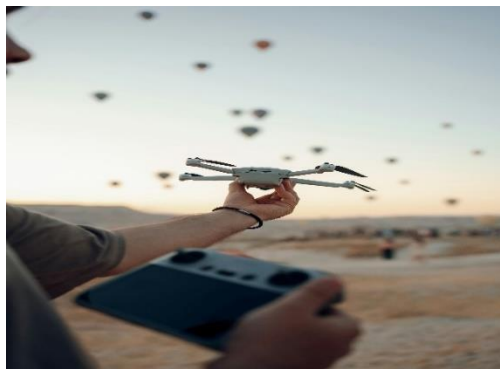

Figure I. 13 Aerial Photography and Videography Using Drones[5]

I.5.2 Agriculture: Drones have found valuable applications in agriculture, providing farmers with valuable data and insights. They can be used for monitoring crops, assessing plant health, precision spraying of fertilizers or pesticides, and creating detailed maps of farmland, helping optimize resource allocation and increase yields.



Figure I. 14 Agricultural Applications of Drones[5]

I.5.3 Delivery Services: Companies like Amazon and other logistics providers are exploring the use of drones for delivering packages. With the ability to navigate quickly and efficiently over short distances, drones can revolutionize last-mile delivery, reducing delivery times and costs.



Figure I. 15 Drones in Delivery Services[5]

I.5.4 Emergency Response: During natural disasters or emergency situations, drones can quickly assess and map affected areas, aiding in disaster management and response efforts.

They can be used for monitoring wildfires, identifying structural damage, and providing real-time situational awareness to emergency responders.



Figure I. 16 Emergency Response with Drones [5]

I.6 Benefits and Drawbacks of Drones

Drones offer many benefits to various industries, but they also come with some drawbacks.

Understanding these advantages and disadvantages is critical to responsible drone use. We're going to explore the advantages and disadvantages of drones:

I.6.1 Benefits:

- **Safety:** Drones can be used in hazardous situations, reducing the risks to human life. They can access remote or dangerous areas for inspection, surveillance, or search and rescue operations without endangering human lives.
- **Accessibility:** Drones are becoming more affordable and user-friendly, allowing more people to experience and benefit from their capabilities. From recreational pilots to professionals in various industries, drones are accessible to a wide range of users.
- **Data Collection:** Drones are equipped with sensors and cameras that enable data collection in ways that were previously impossible or labor-intensive. They provide detailed imagery, aerial mapping, and real-time data streaming, which can be used for analysis, decision-making, and planning in agriculture, construction, and other sectors.
- **Environmental Impact:** Drones have a smaller carbon footprint compared to traditional aircraft, making them a more environmentally friendly option. They produce lower emissions and require less fuel, reducing their impact on the environment.

I.6.2 Drawbacks:

- **Privacy Concerns:** Drones equipped with cameras raise privacy concerns as they can inadvertently invade personal privacy if used irresponsibly or without consent. Stricter regulations and guidelines are being implemented to address these concerns and ensure responsible drone usage.
- **Interference with Air Traffic:** With the increasing popularity of drones, there is a need for careful integration into airspace to avoid conflicts with manned aircraft. Regulations and airspace management systems are being developed to minimize the risks of collisions and maintain a safe environment for all aircraft.
- **Limited Battery Life and Range:** Drones are limited by their battery life, which can vary depending on the size and type of drone. This restriction limits their flight time and range, requiring careful planning and consideration for longer missions or tasks.
- **Misuse and Security Concerns:** Drones can be misused for illegal activities, posing security threats such as unauthorized surveillance, smuggling, or disruptions to public safety. Measures and countermeasures are being developed to detect, prevent, and mitigate these risks.

While drones bring undeniable benefits and potential for innovation, addressing the drawbacks and challenges associated with their use is essential for responsible integration into society. Continued efforts in regulation, education, and technological advancements will contribute to maximizing the benefits while minimizing the risks and drawbacks of drones.

I.7 Future of Drones

The future of drones holds incredible potential as advancements in technology continue to reshape the capabilities and applications of unmanned aerial vehicles. Here are some areas where the future of drones is likely to make a significant impact [6]:

I.7.1 Autonomous Operation: As artificial intelligence and machine learning continue to advance, drones are expected to become more autonomous. They will be equipped with advanced algorithms and sensors, enabling them to navigate complex environments, avoid obstacles, and make intelligent decisions without constant human input. This autonomy will unlock new possibilities for automated tasks and missions.

I.7.2 Urban Air Mobility: With the rise of electric propulsion and advancements in battery technology, the concept of urban air mobility is gaining traction. Drones or electric vertical takeoff and landing (eVTOL) aircraft could be used for short-distance urban transportation, reducing congestion and offering faster commute options. As urban air

mobility infrastructure develops, drones may become an integral part of the transportation ecosystem.

I.7.3 AI-Powered Drones: Drones equipped with artificial intelligence will have the ability to perform more complex tasks. They can analyze data in real-time, make predictive models, and detect anomalies or patterns that may not be easily identifiable by humans. AI-powered drones will find applications in various fields such as agriculture, infrastructure monitoring, and disaster management, providing more efficient and accurate solutions.

I.7.4 Collaborative Swarms: Swarm technology, where multiple drones work together in a coordinated manner, holds great potential. These drone swarms can collaborate on tasks such as search and rescue, surveillance, or mapping. By leveraging swarm intelligence, drones can cover larger areas, share information, and execute tasks more effectively than individual drones.

The future of drones is bright, with ongoing advancements in technology, regulations, and public acceptance. However, challenges remain, such as privacy concerns, airspace management, and ensuring safe integration into existing systems. Addressing these challenges coupled with ongoing innovation will shape the future of drones and enable their widespread adoption in various industries, improving efficiency, safety, and providing new opportunities for businesses and individuals alike.

I.8 Conclusion

In this chapter, we have delved into the world of drones, exploring their definition, history, components, uses, benefits, drawbacks, and future potential. From their origins as military tools to their diverse civilian applications, drones have become essential in fields like aerial photography, agriculture, delivery, and emergency response.

We examined the key components that enable drones to function and highlighted their numerous benefits, such as enhanced safety and efficient data collection. However, we also addressed the challenges they present, including privacy concerns and air traffic interference.

Looking ahead, the future of drones is promising, with advancements in autonomous operation, AI capabilities, and collaborative swarms on the horizon. These developments will expand the possibilities for drones, making them even more integral to various industries.

Chapter I: what a drone and its history

In summary, drones are a rapidly evolving technology with the potential to revolutionize many aspects of our lives. Continued innovation and responsible integration will be key to harnessing their full potential while addressing the challenges they bring.

chapter II

State of the Art

II.1 Introduction

The field of Unmanned Aerial Vehicles (UAVs) has seen significant advancements, sparking considerable interest and innovation in recent years. This chapter delves into the cutting-edge developments in UAV technology, focusing on groundbreaking propulsion systems, hybrid drone designs, and open-source flight controllers and software that facilitate drone development.

II.2 The works that have created buzz recently in UAV field

II.2.1 Replace propellers by ion propulsion:

Ion propulsion is a technique that uses noble atoms to generate electric propulsion, these materials are ionized to put them in plasma state then accelerated by a high voltage electric field, which pushes the ions at very high speed (up to 90000mph) that generates a thrust force opposite to the direction of ions transfer, thus propelling the vehicle. [7]. Historically, the idea of ion propulsion is rather old and dates back to the ideas of rocket scientists [8] Robert Goddard and Konstantin Tsiolkovsky who studies this phenomenon in the early XX century. The plasma physicist Edgard Y. Coueir divide the development of work on ion propulsion into five stages:

- **The era of visionaries (1906-1945):** here where the idea emerged in the scientific community, but it was considered as science fiction.

- **The era of pioneers (1946-1956):** this era is characterized by the work of GLUSHKO who developed the basic ion propulsion model.

- **The era of development (1957-1979):** the highlight of this phase was the launch of NASA's first ion propulsion spacecraft, called SERT-1(space electric rocket-1), on 20 July 1964.

- **The era of acceptance (1980-1992):** this is where the commercial spacecraft industry has embraced the idea of ionic propulsion instead of counting on fuel propulsion.

- **The era of application (1993-present):** Since 1993, this technology has been widely used in spacecraft.[9]

- **Uses of ion propulsion in drones:** One of the research projects we found uses ionic propulsion to lift drones is the SILENT VENTUS cargo drone project founded by the UNDEFINED TECHNOLOGIES start-up. According to NewAtlas website:

“The "Silent Ventus" drone doesn't use propellers to fly. Instead, its entire broad structure creates two stacked grids of electrodes, designed to create high-voltage electric fields that can ionize the oxygen and nitrogen molecules in the air, freeing electrons to give them a positive charge, and then propelling these downward to create an "ionic wind" that can produce thrust.”[10].

In addition, this start-up shares a video on their webpage shows that SILENT VENTUS has complete a 4-1/2 min of flight with noise level below 75dB, those two results are considering as success for the project during this phase. [11]



Figure II. 1 Silent Ventus Hybrid Drone[10]

II.2.2 Hybrid drones:

The development of science in the field of land, air and sea has led to the emergence of many ideas in combining these arts especially in drones. Hybrid types of these UAV have appeared, some of them can dive and fly at the same time and others can drive on land and fly at the same time as well, so we will try to show what we were able to find of those types.

II.2.2.1 Aerial-aquatic drones (UAV-UUV):

- A. **TJ-Fling Fish:** this drone utilizes arm tilting technology mechanisms, which helps it to navigate well underwater. and according to New Atlas web page “the 1.63-kg (3.6-lb) TJ-FlyingFish can hover for six minutes per battery-charge, or move underwater for 40 minutes. It's also capable of

Chapter II: State of Art

descending to a maximum depth of 3 m (9.8 ft), and has a top underwater speed of 2 m (6.6 ft) per second.”

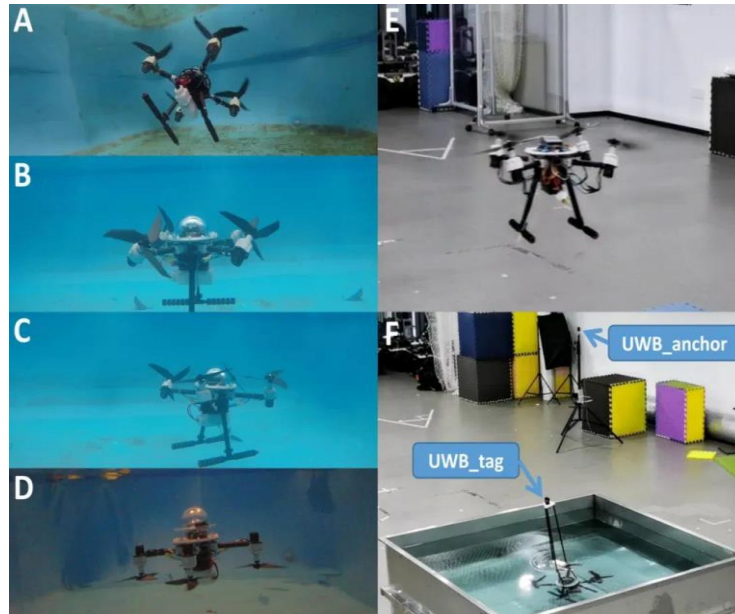

Figure II. 2 TJ-Fling Fish[10]

- B. Aerial-aquatic hitchhiking robot:** this drone can dive and flight in the same with a transition water-to-air time of 0.35 seconds, and it possess a surface adhesion feature adapted from the Remora disc.



Figure II. 3 Aerial-Aquatic Hitchhiking Robot[10]

Chapter II: State of Art

C. **Dipper:** it is a fixed-wing drone developed at ETH ZURICH university in Switzerland, where the ASL lab (autonomous system lab) at the same university broadcast a video on YouTube show us the general characteristics of Dipper, which are as follows:

- Radio range up to 5 KM.
- One propeller.
- Speed can reach 70 KM/H.
- Maximum speed under water 9 KM/H for 10 minutes.
- Falls into water from a maximum distance of 150 meters at 130 KM/H.
- It needs 3 second to get stable after water to air transaction. [12]

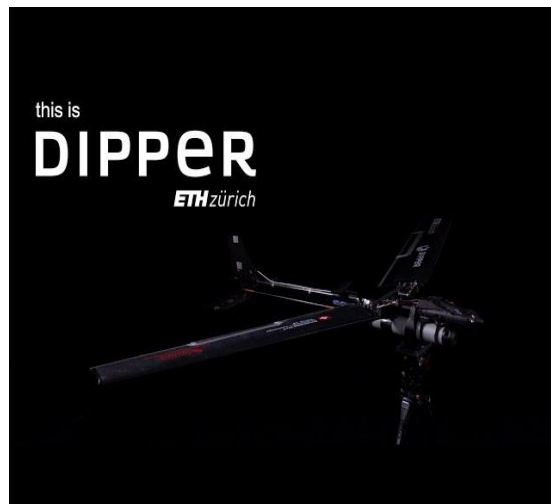

Figure II. 4 Dipper Fixed-Wing Drone by ETH Zurich[12]

II.2.2.2 Aerial-terrestrial drones (UAV-UGV):

A. **Rollocopter:** “Rollocopter, a hybrid aerial and terrestrial platform, uses a quadrotor system to fly or roll along on two passive wheels. This design gives the robot greater range than aerial-only quadrotors and eliminates obstacle-avoidance issues associated with ground-only robots. When Rollocopter encounters an obstacle, it can simply fly over it. To fly this robot requires a celestial body with an atmosphere and could be used to explore subterranean caves other worlds.”

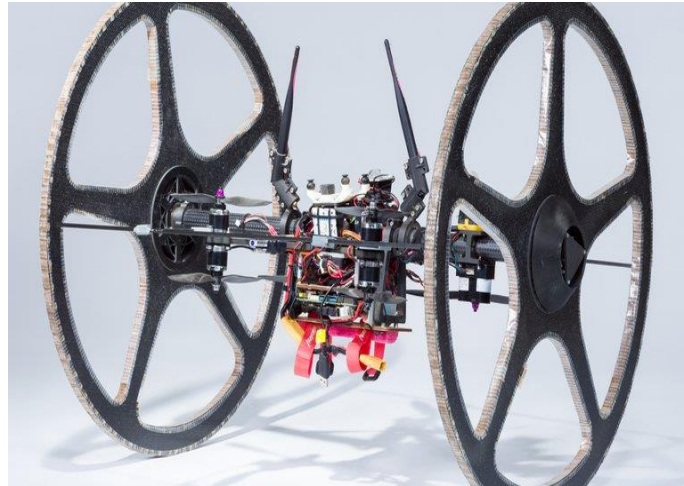

Figure II. 5 Rollocopter Hybrid Aerial and Terrestrial Drone

B. HUUVER: “The project HUUVER - Hybrid UAV-UGV for Efficient Relocation of Vessels will result with a prototype UAV-UGV platform that combines two types of propulsion systems. This patented technical solution will activate flying and driving capabilities in one compact and highly integrated autonomous drone.

The HUUVER drone will be the first fully integrated with the Galileo navigation system that provides the authentication service and precise navigation and will be fundamental in the navigation system.”[13]



Figure II. 6 HUUVER Hybrid UAV-UGV[13]

II.3 Open-source flight controller and software

There are currently a group of platforms that make drone domain easy. In the past, building drones required a mechanical, software and electronics study, so some laboratories sought to summarize this method and provide a comfortable open-source environment such as flight controllers, software and frames, so we will try to show the most important and famous of them:

II.3.1 Open-source flight controllers (OSH):

Existing flight controllers differ and share many aspects, but the important point is the type of microcontroller used in, so we divide these controllers according to the MCU type inside:

II.3.1.1 FPGA based platform:

A. OCPOC (octagonal pilot on chip):

“The OcPoC (Octagonal Pilot on Chip) flight control platform, built completely from scratch by the Aerotenna team, is engineered to be a ready-to-fly “box” with integrated IMU, Barometer and GPS receiver, and features a CSI-camera interface to support high-resolution video streaming. The Altera Cyclone V SoC FPGA, functioning as the brain of the platform, provides clear advantages in terms of processing power and I/O capability.” [14]



Figure II. 7 OCPOC (Octagonal Pilot on Chip) Flight Controller[14]

B. PHENIX PRO:

“It is built on reconfigurable system on a chip (SOC) designed and developed by Robsense Tech, founded in 2015 and located in Hangzhou China, the flight controller

is equipped with real-time operation system and Linux based robot operating system (ROS). The flight platform support +20 interfaces including on-board-sensor, MMWAVE radar, Lidar, Thermal camera, ultra-vision HD, video transceiver via software defined radio, etc. In addition, its hardware (FPGA) acceleration enables computer vision and deep neural network algorithms application.” [15]

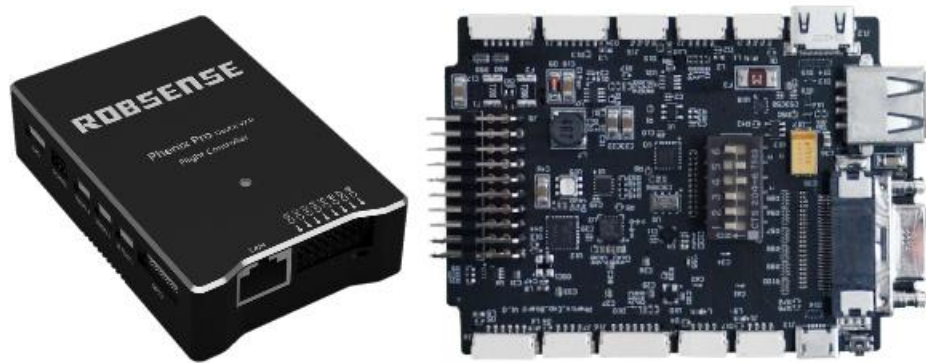

Figure II. 8 PHENIX PRO Reconfigurable Flight Controller[15]

II.3.1.2 ARM based platform:

- A. **PIXHAWK:** was a student project at ETH Zurich[16], “Pixhawk collaborates with several partners, including the Linux Foundation Drone Code project. It is based on the PX4-Flight Management Unit (FMU) and multiple versions have been developed.”[17]. Among its versions are Pix4 FMU, Pixhawk, Pixhawk2, PixRacer, Pixhawk 3 pro are based on stm32f4 and Pixhawk 4, Pixhawk 5x are based on stm32f4, and Pixhawk 6 is based on stm32H7. In addition, some of them used a stm32f1 as co-processor in case of failing of main microcontroller.[18]



Figure II. 9 PIXHAWK Flight controller[18]

Chapter II: State of Art

- B. SPARKY:** “The Sparky2 is an OSH platform from TauLabs. It is based on the STM32F405 Microcontroller Unit.”



Figure II. 10 SPARKY Flight controller

- C. PAPARAZZI CHIMERA:** it is an STM32F767 based open-source flight controller released by ENAC (ECOLE NATIONAL de L'AVIATION CIVILE) lab team in October 2016[19], but the first UAV controller founded by ENAC is PAPARAZZI in 2003.[20]

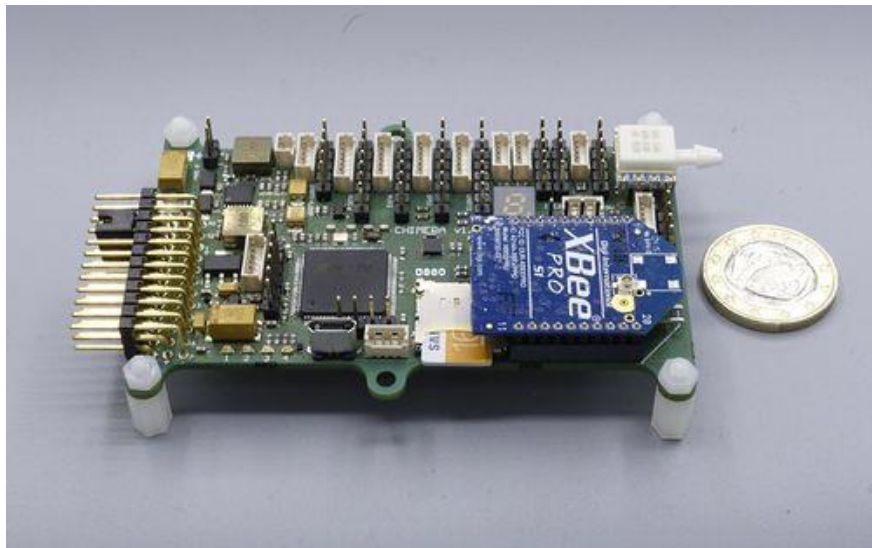

Figure II. 11 PAPARAZZI CHIMERA Open-Source Flight Controller by ENAC[20]

- D. ATOM & CC3D:** CC3D is the next generation board of Copter Control flight controller released by Open Pilot, this new version differs of the oldest by using a good generation of gyroscopes, ATOM is the latest version of this family, it is identical to CC3D but in smaller size. These flight controllers are based on stm32f103c8t microcontroller.[21]

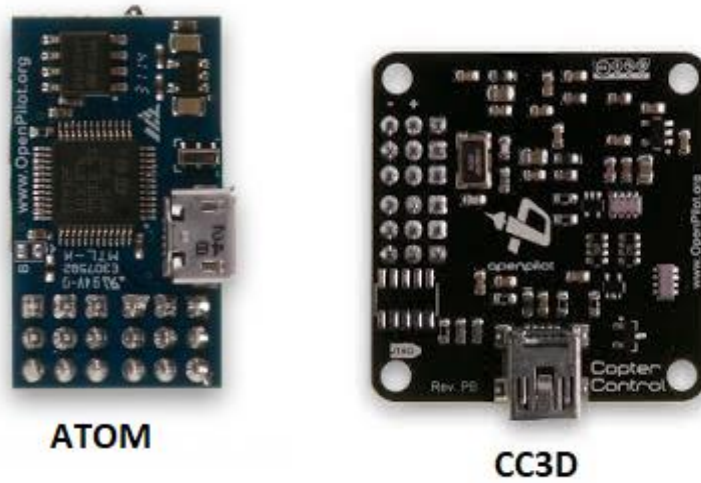

Figure II. 12 ATOM & CC3D Flight Controllers by OpenPilot[21]

E. FLYMAPLE:

”Flymaple is a Quad copter controller board, based on the Maple Project. The FlyMaple embeds a STM32F103RET6 (ARM Cortex-M3) as its main MCU. It integrates a 3-Axis accelerometer, a 3-Axis gyroscope, a 3-Axis compass and a barometric pressure sensor.”[22]

We should note that this flight controller is not supported now (discontinue).

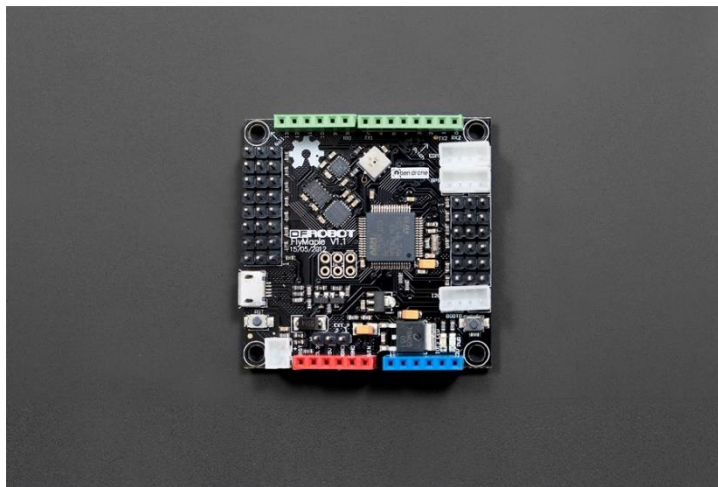

Figure II. 13 FLYMAPLE Quadcopter Controller Board[22]

II.3.1.3 ATMEL based platform:

APM 2.8: “It is an arduino MEGA based autopilot system developed by DIY drones’ community as an upgrade of ArduPilot flight controller, it is able to control autonomous multi-copter, fixed wing aircraft, traditional helicopter, ground rover and antenna trackers.”

It is not supported any more, It steel work but with old software.[23]

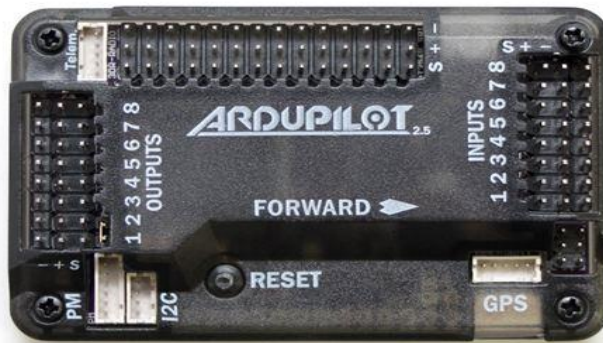

Figure II. 14 ArduPilot Arduino Mega-Based Autopilot System[23]

II.3.1.4 Raspberry based platform:

A. PXFMINI:

“The PXFmini (Pixhawk Fire Cape Mini) Autopilot Shield made by Erle Robotics is a low cost and open autopilot shield for the Raspberry Pi that allows you to create a ready-to-fly autopilot with support for ArduPilot. The shield has been designed especially for the Raspberry Pi Zero but it is also pin to pin compatible with other models from the Raspberry Pi family.”[24]

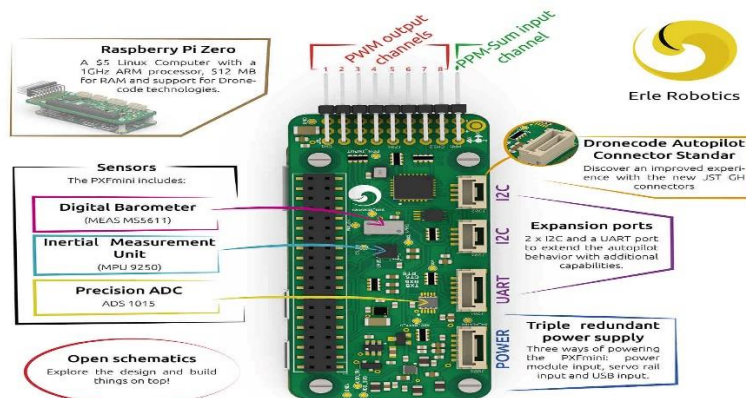

Figure II. 15 PXFMINI Autopilot Shield[24]

B. ERLE-BRAIN 3:

“Erle-brain is an open hardware and open_source Linux-based autopilot to make drones. It consists of a BeagleBone Black and a PixHawk Fire Cape (PXFmini) and comes with a Debian image flashed, ROS preinstalled and the latest ready to fly code.”[25]

We should note that Debian is an operating system based on Linux kernel.[26]

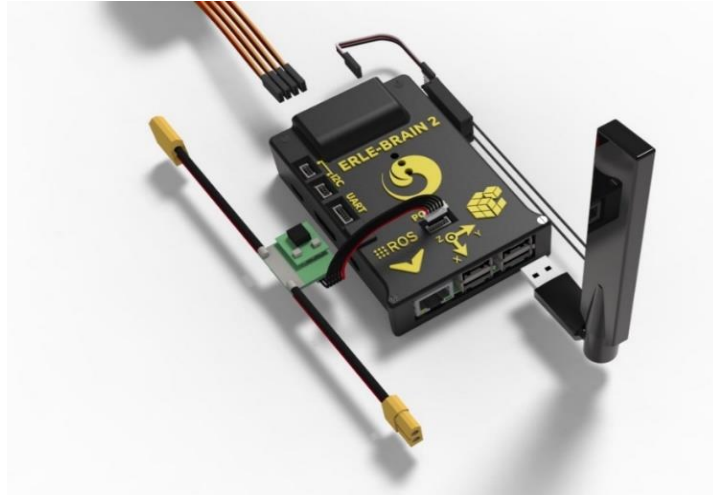

Figure II. 16 ERLE-BRAIN 3[26]

II.3.2 Open-source software (OSS) and simulation platforms:

It is a set of open-source software that works to configure flight controllers (communication channel, motors placement, verify sensors, drone calibration) and modify their software, each OSS support a set of flight controllers, and many of them can include the mission planner and ground control station functions. In addition, there are an open-source simulation platforms in robotic domain that can be used for drone simulation. Here is what we were able to find from these programs:

II.3.2.1 Open-source platforms:

A. ArduPilot (mission planner): according to autopilot official website:

“ArduPilot is a trusted, versatile, and open-source autopilot system supporting many vehicle types: multi-copters, traditional helicopters, fixed wing aircraft, boats, submarines, rovers and more. The source code is developed by a large community of professionals and enthusiasts.”[27]

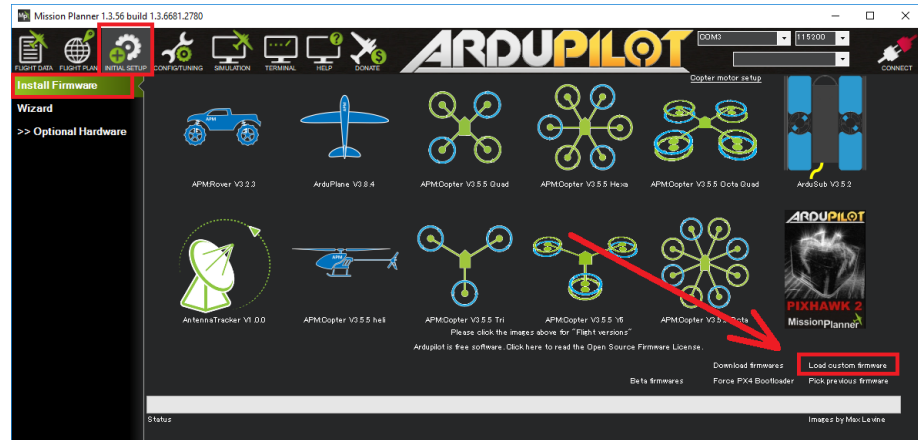

Figure II. 17 ArduPilot Mission Planner Interface[27]

B. PX4 (Ground control):

“PX4 is an open-source flight control software for drones and other unmanned vehicles. The project provides a flexible set of tools for drone developers to share technologies to create tailored solutions for drone applications. PX4 is hosted by Drone code, a Linux Foundation non-profit.”[28]

This software is developed in ETH Zurich University, as a same project with pixhawk flight controller.

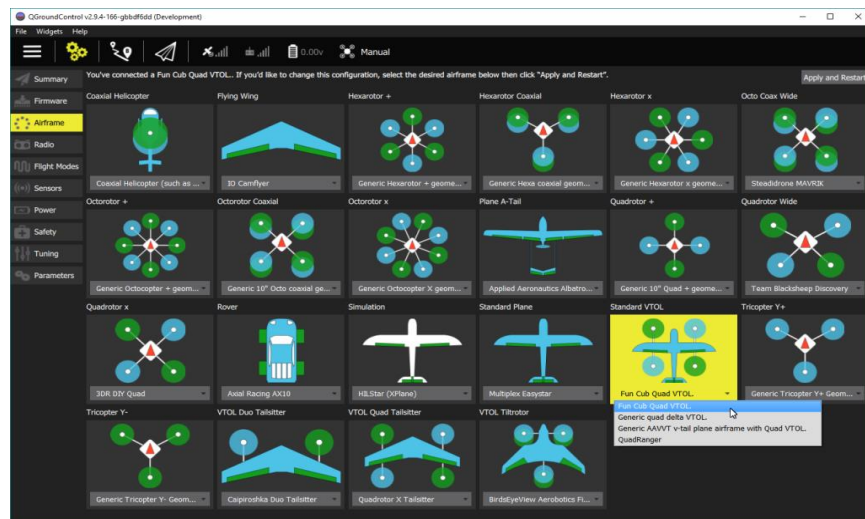

Figure II. 18 PX4 Ground Control Interface[28]

C. LibrePilot/OpenPilot: LibrePilot is founded in July 2015[29]. The old version is OpenPilot but it is not supported software. [30]

“You can use the LibrePilot Ground Control Station (GCS) both to configure your controller board and to control and monitor your aircraft during flight. More commonly, you would use a

Chapter II: State of Art

conventional radio control transmitter to control your vehicle, but the GCS is also capable of doing so.”[31]

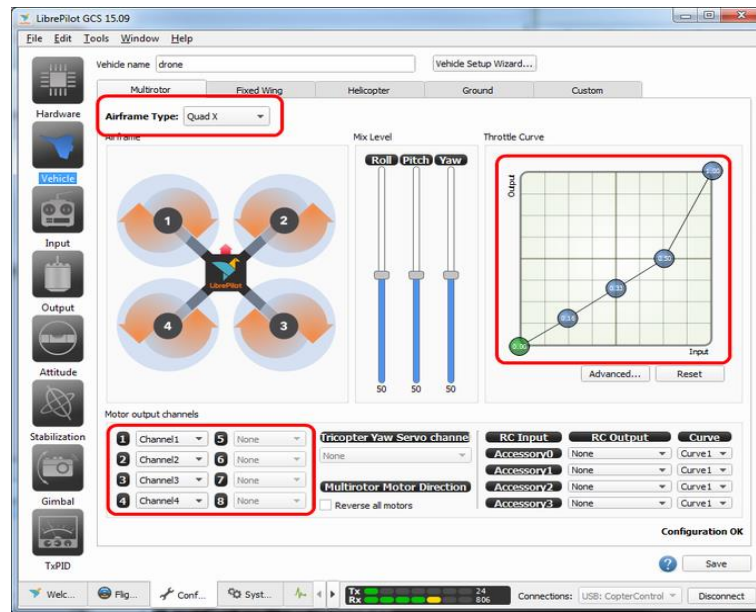

Figure II. 19 LibrePilot/OpenPilot Interface[31]

- D. **Multiwii:** this software is developed to use an Arduino board with Nintendo wii sensors to build a flight controller.[32]

In addition, this software was the starting point for several programs like BetaFlight and Base Flight.

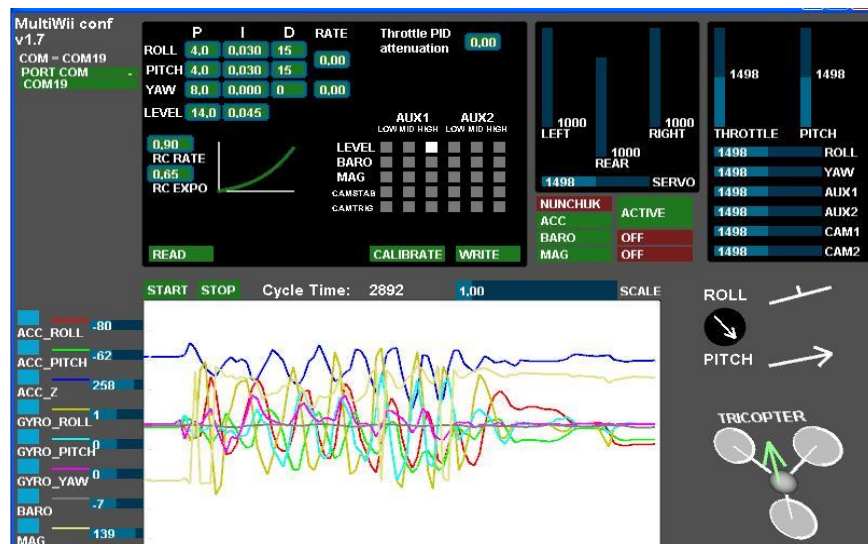

Figure II. 20 Multiwii Interface[32]

II.3.2.2 Open-source simulation platform:

A. JmavSim (java micro air vehicle simulator) :

“jMAVSim is a simple multirotor/Quad simulator that allows you to fly copter type vehicles running PX4 around a simulated world. It is easy to set up and can be used to test that your vehicle can take off, fly, land, and responds appropriately to various fail conditions (e.g. GPS failure).”[33]

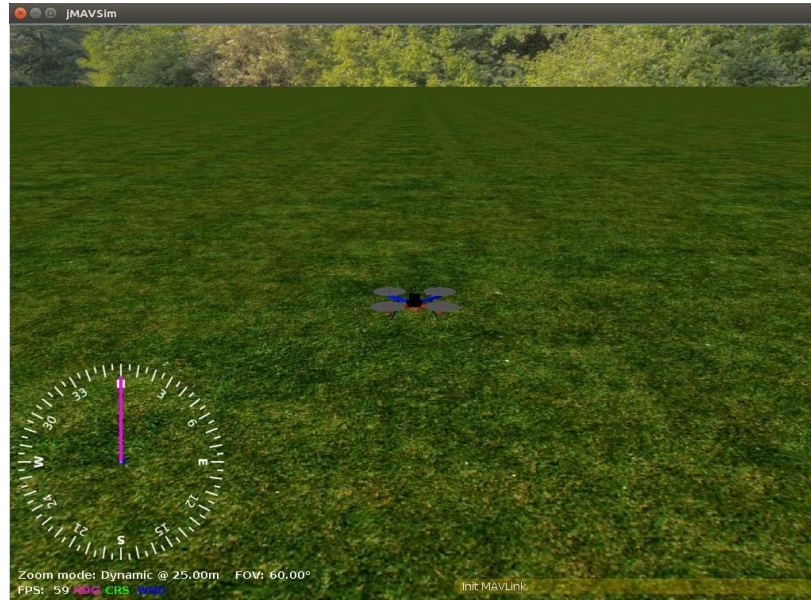

Figure II. 21 JmavSim (Java Micro Air Vehicle Simulator)[33]

B. Gazebo: according to their official website: “Gazebo is a 3D dynamic simulator with the ability to accurately and efficiently simulate populations of robots in complex indoor and outdoor environments. While similar to game engines, Gazebo offers physics simulation at a much higher degree of fidelity, a suite of sensors, and interfaces for both users and programs.”[34]

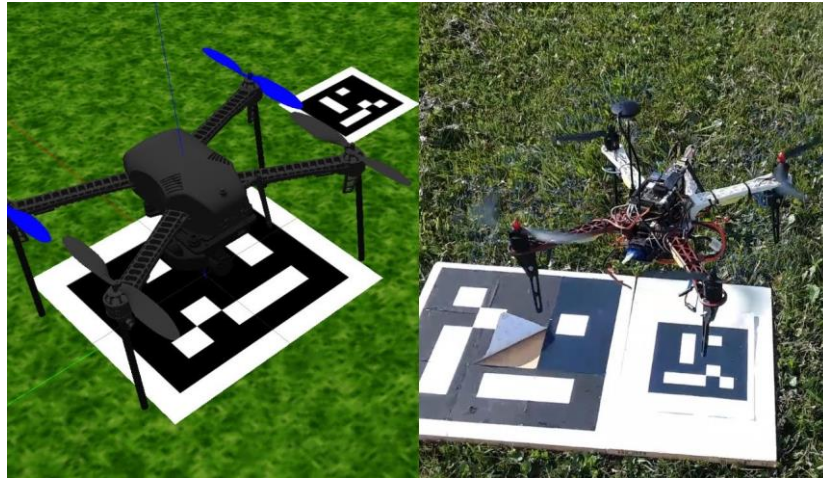

Figure II. 22 Gazebo Simulator Interface[34]

C. **Morse:** “MORSE is a generic simulator for academic robotics. It focuses on realistic 3D simulation of small to large environments, indoor or outdoor, with one to tens of autonomous robots.” Also, it supports python, and many sensors types that come with it, in case when there is no sensors it allow us to made our special sensor.[35]



Figure II. 23 Morse Simulator Interface[35]

D. **AirSim:** this software was realized in 2017 by Microsoft.

Chapter II: State of Art

“AirSim is a simulator for drones, cars and more, built on Unreal Engine (we now also have an experimental Unity release). It is open-source, cross platform, and supports software-in-the-loop simulation with popular flight controllers such as PX4 & ArduPilot and hardware-in-loop with PX4 for physically and visually realistic simulations. It is developed as an Unreal plugin that can simply be dropped into any Unreal environment. Similarly, we have an experimental release for a Unity plugin.”[36]



Figure II. 24 AirSim Simulator Interface[36]

II.4 Conclusion

build and develop new drone technology or used it in application is more simply than before, many tools are open source with high efficiency for both soft and hard. The large variety of open-source flight controllers allow us to choose the best one for a specific project, according to their performance, size, and price. In other hand, those controllers should be supported by software to configure or simulate them. Also, the large community in each platform help to share problems and get feedback solution. Now it is easy for students, engineers, teachers and Hobbyist to take first step in drone domain.

chapter III

Conceptual Study

III.1 Introduction

The rapid evolution of unmanned aerial vehicles (UAVs) has placed a premium on the development of flight controllers that are efficient, accurate, and responsive. At the heart of every flight controller lies the microcontroller, which serves as the brain responsible for processing sensor data, running flight algorithms, and managing communication. This chapter delves into the importance of selecting the right microcontroller for a drone flight controller, focusing on the STM32F407VET6 as the core processor. It also explores the criteria for selecting the microcontroller and describes the selection process for other critical components, such as sensors, actuators, and communication modules. Finally, it justifies the chosen components based on the project requirements.

III.2 Importance of Selecting the Right Microcontroller for a Drone Flight Controller

A microcontroller is central to the efficient operation of a drone flight controller because it must:

- **Real-Time Processing:** Process data from various sensors in real-time to ensure stability and precision.
- **Responsiveness:** Quickly interpret and act on commands and changes in environmental conditions.
- **Power Efficiency:** Operate efficiently to maximize battery life during flight.

III.3 Criteria for Selecting the STM32F407VET6 Microcontroller

III.3.1 Processing Power

- **Core Architecture:** ARM Cortex-M4 core with a 32-bit architecture and an FPU for efficient processing of flight algorithms.
- **Clock Speed:** Up to 168 MHz, ensuring rapid data processing and computation.
- **Memory:** 512 KB of Flash memory and 192 KB of SRAM, providing ample space for complex flight firmware.

III.3.2 I/O Capabilities

- **GPIO (General-Purpose Input/Output):** Over 80 GPIO pins for versatile connections.
- **Communication Interfaces:**

Chapter III: Conceptual Study

- **I²C:** Supports multiple I²C buses for sensor integration.
- **SPI:** Up to three SPI interfaces for high-speed communication with sensors and communication modules.
- **UART:** Up to six UART interfaces for telemetry, GPS, and other modules.
- **CAN Bus:** Dual CAN bus controllers for additional peripherals.
- **USB:** Supports both full-speed and high-speed communication.

- **PWM (Pulse Width Modulation):** 12 channels suitable for controlling multiple motors.

- **ADC (Analog-to-Digital Converter):** Three ADCs with 12-bit resolution for reading analog sensor data.

III.3.3 Power Consumption

- **Power Efficiency:** Sleep and low-power modes reduce energy consumption during idle periods.

- **Voltage Range:** Operates between 1.8V to 3.6V, suitable for battery-powered applications.

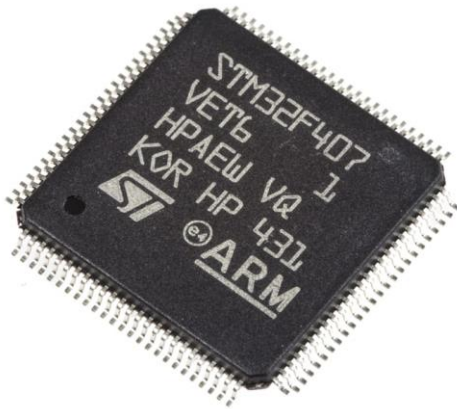

Figure III. 1 STM32F407VET6 Microcontroller Annex2.1

III.4 Process of Selecting Other Components

III.4.1 Sensors

Accurate and responsive sensors are essential for real-time stabilization and navigation. The following sensors were chosen for the drone flight controller:

Chapter III: Conceptual Study

III.4.1.1 SPL06-001 (Barometric Pressure Sensor)

- **Purpose:** Altitude measurement for stable hovering and vertical navigation.
- **Features:**
 - **Pressure Range:** 300 to 1200 hPa
 - **Resolution:** 0.002 hPa (altitude resolution of 0.5 m)
 - **Interface:** I²C/SPI
- **Justification:** High-resolution altitude measurement ensures precise hovering.



Figure III. 2 SPL06-001 (Barometric Pressure Sensor) Annex2.2

III.4.1.2 ICM-20689 (Inertial Measurement Unit)

- **Purpose:** Measures 6-axis motion (3-axis accelerometer, 3-axis gyroscope) for orientation and stabilization.
- **Features:**
 - **Gyroscope Range:** $\pm 250/500/1000/2000$ °/s
 - **Accelerometer Range:** $\pm 2/4/8/16$ g
 - **Interface:** I²C/SPI
- **Justification:** Provides accurate orientation data for flight stabilization.

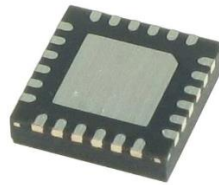

Figure III. 3 ICM-20689 (Inertial Measurement Unit) Annex2.3

III.4.1.3 MPU6500 (Inertial Measurement Unit)

- **Purpose:** Measures 6-axis motion (3-axis accelerometer, 3-axis gyroscope) for orientation and stabilization.
- **Features:**
 - **Gyroscope Range:** $\pm 250/500/1000/2000$ °/s
 - **Accelerometer Range:** $\pm 2/4/8/16$ g
 - **Interface:** I²C/SPI
- **Justification:** Serves as a backup IMU to improve reliability.



Figure III. 4 MPU6500 (Inertial Measurement Unit) Annex2.4

III.4.1.4 BM1422AGMV-ZE2 (Magnetometer)

- **Purpose:** Provides accurate heading information to aid in navigation.
- **Features:**
 - **Magnetic Range:** ± 1200 μ T
 - **Resolution:** 0.3 μ T

Chapter III: Conceptual Study

- **Interface:** I²C
- **Justification:** Accurate heading information ensures reliable navigation.

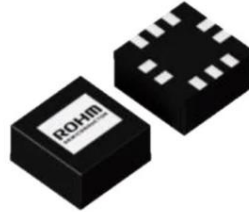

Figure III. 5 BM1422AGMV-ZE2 (Magnetometer) Annex2.5

III.4.1.5 NEO-6M (GPS Module)

- **Purpose:** Provides accurate position data for navigation.
- **Features:**
 - **Frequency:** L1 band, 1575.42 MHz
 - **Accuracy:** 2.5 m (CEP)
 - **Time-to-First-Fix:** Cold start: 27 s; Hot start: 1 s.
 - **Interface:** UART
- **Justification:** Accurate position data ensures precise waypoint navigation.



Figure III. 6 NEO-6M (GPS Module)

Chapter III: Conceptual Study

III.4.2 Actuators

Responsive and efficient actuators are vital for stable flight. The chosen actuators include:

III.4.2.1 Brushless DC Motors (A2212/6 - 2200Kv)

- **Purpose:** Provide thrust for the drone.
- **Features:**
 - **Kv Rating:** 2200 Kv
 - **Voltage Range:** 2S-3S LiPo batteries
 - **Max Thrust:** 700 g per motor
- **Justification:** High Kv rating provides rapid acceleration, suitable for agile drones.



Figure III. 7 Brushless DC Motors (A2212/6 - 2200Kv)

III.4.2.2 Electronic Speed Controllers (ESC 30A)

- **Purpose:** Control the speed of the brushless motors.
- **Features:**
 - **Current Rating:** 30A
 - **Firmware:** BLHeli firmware for rapid throttle response.

Chapter III: Conceptual Study

- **Justification:** High current rating and BLHeli firmware ensure quick response for stable flight.



Figure III. 8 Electronic Speed Controllers (ESC 30A)

III.4.3 Communication Modules

Effective communication is necessary for flight control and telemetry data. The chosen communication modules are:

III.4.3.1 nRF24L01-PA-LNA Module

- **Purpose:** Enables bi-directional communication for control commands and telemetry data.
- **Features:**
 - **Frequency:** 2.4 GHz ISM band
 - **Range:** Up to 1 km with PA-LNA (Power Amplifier-Low Noise Amplifier)
 - **Data Rate:** 250 kbps - 1 Mbps - 2 Mbps
 - **Interface:** SPI
- **Justification:** Long-range communication and high data rates ensure reliable control and telemetry.



Figure III. 9 nRF24L01-PA-LNA Module

III.5 Conclusion

In summary, selecting the right components for a drone flight controller involves carefully balancing processing power, I/O capabilities, power consumption, and responsiveness. The STM32F407VET6 microcontroller was chosen as the brain of the flight controller due to its robust processing capabilities, extensive I/O support, and efficient power management. The selected sensors, actuators, and communication modules were chosen based on the specific requirements of the project, ensuring accurate stabilization, navigation, and control of the drone.

chapter IV

Implementation of Drone Systems through PCB Design

IV.1 Introduction

This chapter delves into the critical role that Printed Circuit Boards (PCBs) play in the functionality and reliability of drone systems. PCBs are the backbone of electronic components, providing the necessary physical support and electrical connectivity for various parts of a drone. The chapter aims to elucidate the integration of PCBs into the broader architecture of drone technology, highlighting their design, implementation, and testing processes.

Focusing on creating three key PCBs—the flight controller, power distribution board, and remote-control unit—this chapter underscores their importance in ensuring stable flight, efficient power management, and effective communication between the pilot and the drone. Understanding the design and integration of these PCBs is crucial for enhancing drone technology, paving the way for future advancements and innovations.

IV.2 Design Principles for Drone PCBs

IV.2.1 Overview of PCB Design

Designing Printed Circuit Boards (PCBs) for drones involves adhering to several fundamental principles to ensure optimal performance and reliability. Key aspects include[38]:

IV.2.1.1 Assembly capabilities

Ensures precise placement and assembly of various electronic components onto the PCB.

Chapter IV: Implementation of Drone Systems through PCB Design

PCB Assembly Capabilities

Features	Economic PCBA	Standard PCBA
Assembly Types	Single sided placement (SMT/Thru-hole)	Single & double sided placement (SMT/Thru-hole)
PCB Layer	2,4,6 layers	1 - 20 layers
Thickness	0.8mm - 1.6mm	0.4mm - 2.0mm
Dimension	Single PCB Size: 10x10mm - 470x500mm PCB Panel Size: 10x10mm - 250x250mm	Single PCB Size: 70x70mm - 480x500mm PCB Panel Size: 70x70mm - 250x250mm
Order Volume	2 - 50 pcs	2 - 80000 pcs
Surface Finish	Limited by specific options (Refer to the options for Economic PCBA in the table below)	No limit
PCB Color	Limited by specific options (Refer to the options for Economic PCBA in the table below)	No limit
Delivery Format	Single PCB, Panel with mouse bites	Single PCB, Panel with mouse bites, Panel with V-cut
Layer Stackup	Standard stack-up only, special stack-up is not supported	All stack-up
Gold Fingers/Castellated Holes/Edge Plating	Not Support	Support
Edge Rails	Not necessary	Necessary
Fiducials	Not necessary	Necessary
Minimum Package	0402	0201
Minimum IC Pin Spacing	0.4mm	0.35mm
Minimum BGA Spacing	0.5mm(center to center)	0.35mm(center to center)
Reflow temperature	255+/-5 °C (not adjustable)	240+/-5 °C
SPI	No	Yes
AOI	Yes	Yes
Visual Inspection	Yes	Yes
X-ray Inspection	Yes	Yes
Build time	1 - 3 days	≥ 4 days

Figure IV. 1 Assembly capabilities[38]

IV.2.1.2 Minimum Clearance

Defines the smallest permissible distance between conductive elements to prevent electrical shorts.

Minimum clearance ▼		
Features	Capability	Patterns
Hole to hole clearance(Different nets)	0.5mm	
Via to Via clearance(Same nets)	0.254mm	
Pad to Pad clearance(Pad without hole, Different nets)	0.127mm	
Pad to Pad clearance(Pad with hole, Different nets)	0.5mm	
Via to Track	0.254mm	
PTH to Track	0.33mm	
NPTH to Track	0.254mm	
Pad to Track	0.2mm	

Figure IV. 2 Minimum Clearance[38]

IV.2.1.3 Drill/Hole Size

Specifies the diameters of holes for vias and component leads in the PCB.

Chapter IV: Implementation of Drone Systems through PCB Design

Drill/Hole Size ▼			
Features	Capability	Notes	Patterns
Drill Hole Size	0.15mm - 6.30mm	1 & 2 Layer PCB: 0.3 - 6.3mm Multi-Layer PCB: 0.15 - 6.3mm (0.15mm more costly)	
Drill Hole Size Tolerance	+0.13/-0.08mm	e.g. for the 0.8mm hole size, the finished hole size between 0.52mm to 0.73mm is acceptable.	
Blind/Buried Vias	Don't support	Currently we don't support Blind/Buried Vias, only make through holes.	
Min. Via hole size/diameter	0.15mm / 0.25mm	- 1 & 2 Layer PCB: 0.3mm(hole size) / 0.5mm(diameter) - Multi-Layer PCB: 0.15mm(Via hole size) / 0.25mm(Via diameter) ① Via diameter should be 0.1mm(0.15mm preferred) larger than Via hole size ② Preferred Min. Via hole size: 0.2mm	
PTH hole Size	0.20mm - 6.35mm	The annular ring size will be enlarged to 0.15mm in production.	
Pad Size	Minimum 1.0mm	The pad size will be enlarged by 0.5mm than the hole size. The minimum size of annular ring around plated through hole pads is 0.25mm. If the recommended sizes are not respected then the pad will not be produced properly.	
Min. Non-plated holes	0.50mm	The minimum NPTH dimension is 0.50mm, Please add the NPTH in the mechanical layer or keep out layer.	
NPTH	0.2mm	We make NPTH via dry sealing film process, if customer would like a NPTH but around with pad/copper, our engineer will dig out around pad/copper about 0.2mm-0.25mm, otherwise the metal portion will be flowed into the hole and it becomes a PTH. (there will be no copper dig out optimization for single board).	

Chapter IV: Implementation of Drone Systems through PCB Design





Min. Plated Slots	0.5mm	The minimum plated slot width is 0.5mm, which is drawn with a pad.	
Min. Non-Plated Slots	1.0mm	The minimum Non-Plated Slot Width is 1.0mm, please draw the slot outline in the mechanical layer(GML or GKO)	
Min. Castellated Holes	0.60mm	A castellated pad includes a plated half-hole on the edge of a board, usually used on daughter PCB modules to solder to carrier boards. ① Hole diameter ≥ 0.6 mm ② Hole to board edge ≥ 1 mm ③ Min. board size 10×10 mm	
Hole size Tolerance (Plated)	+0.13mm/-0.08mm	e.g. for the 1.00mm Plated hole, the finished hole size between 0.92mm to 1.13mm is acceptable.	
Hole size Tolerance (Non-Plated)	± 0.2 mm	e.g. for the 1.00mm Non-Plated hole, the finished hole size between 0.80mm to 1.20mm is acceptable.	
Rectangle Hole/Slot	Don't support	Rectangle/Square Slots, we don't make rectangular or square plated holes, only make oval or round plated slots. For non-plated slots, rounded corner-rectangular or square slots are supported. The recommended minimum size is 3x3mm.	

Figure IV. 3 Drill/Hole Size[38]

IV.2.1.4 Solder Mask

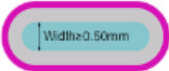
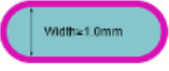
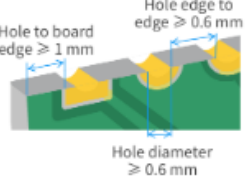
Ensures adequate spacing and protection on PCBs through precise solder mask expansion, minimum solder bridges, reliable via covering, a variety of color options, defined dielectric constant, and optimal ink thickness.

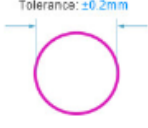
Chapter IV: Implementation of Drone Systems through PCB Design

Solder Mask			
Features	Capability	Notes	Patterns
Soldermask Expansion	0.038mm	2 layer: Expansion ≥ 0.038 mm each side; Edge of opening to adjacent traces ≥ 0.05 mm. Multilayer: No expansion required	
Min. Solder bridge	0.10mm	2 layers: 0.10 mm regular, 0.08 mm minimum (0.13 mm with black or white soldermask). Multilayer: 0.08 mm (0.13 mm with black or white soldermask). Soldermask webs are possible between pads at least 4 mil apart.	
Via Covering	Epoxy Filled & Capped Copper paste Filled&Capped	Via hole size: 0.2 to 0.5 mm Annular ring: 0.05 mm minimum, 0.075 mm preferred The via-in-pad must be placed more than 1.0 mm from regular PTHs or NPTHs Learn more>	
Solder mask color	green, red, yellow, blue, white, and black.	We use LPI (Liquid Photo Imageable) solder mask. It is the most common type of mask used today.	
Solder mask dielectric constant	3.8		
Solder mask ink thickness	10-15UM		

Figure IV. 4 Solder Mask[38]

IV.2.1.5 PCB Specifications

Covers layer count, impedance control, materials, dielectric constants, dimensions, tolerances, thickness, copper weights, and surface finishes.

Chapter IV: Implementation of Drone Systems through PCB Design

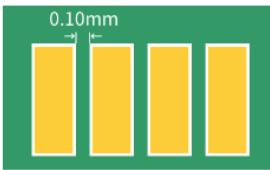
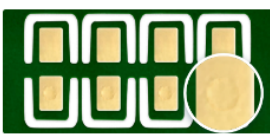

PCB Specifications			
Features	Capability	Notes	Patterns
Layer count	1-20 Layers	The number of copper layers in the board.	
Controlled Impedance	4/6 layer, default layer stack-up	Controlled Impedance PCB Layer Stackup JLCPCB Impedance Calculator	
Material	FR-4 Aluminum Copper core Rogers / PTFE Teflon	FR-4: Tg 135 / Tg140 / Tg155 / Tg170 Aluminum thermal conductivity: 1W/m.K Copper core thermal conductivity: 380W/m.K	
Dielectric constant	4.5(double-sided PCB)	7828 Prepreg 4.4 3313 Prepreg 4.1 2216 Prepreg 4.16	
Max. Dimension	400x500mm	The maximum dimension JLCPCB can accept	
Dimension Tolerance	±0.1mm	±0.1mm(Precision) and ±0.2mm(Regular) for CNC routing, and ±0.4mm for V-scoring	
Board Thickness	0.4 - 2.5 mm	Thickness for FR4 are: 0.4/0.6/0.8/1.0/1.2/1.6/2.0 mm (2.5 mm only available with 12 layers or more.)	
Thickness Tolerance (Thickness≥1.0mm)	± 10%	e.g. For the 1.6mm board thickness, the finished board thickness ranges from 1.44mm(T-1.6×10%) to 1.76mm(T+1.6×10%)	
Thickness Tolerance (Thickness<1.0mm)	± 0.1mm	e.g. For the 0.8mm board thickness, the finished board thickness ranges from 0.7mm(T-0.1) to 0.9mm(T+0.1).	
Finished Outer Layer Copper	1 oz / 2 oz (35um / 70um)	Finished copper weight of outer layer is 1oz or 2oz.	
Finished Inner Layer Copper	0.5 oz / 1 oz / 2 oz (17.5um / 35um / 70um)	Finished copper weight of inner layer is 0.5oz by default.	
Surface Finish	HASL (lead / lead-free), ENIG, OSP (copper core boards only)	FR4 has all three finishes available, 6+ layers and RF boards only have ENIG. Aluminium core boards only have HASL. Copper core boards only have OSP.	

Figure IV. 5 PCB Specifications[38]

IV.2.1.6 Minimum Trace Width and Spacing

Sets the smallest width of conductive traces and the minimum distance between them on the PCB.

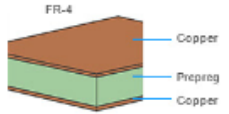
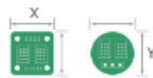
Minimum trace width and spacing			
	Min. Trace width	Min. Spacing	Patterns
1-2 Layers	5mil (0.127mm)	5mil (0.127mm)	
4-6 Layers	3.5mil (0.09mm)	3.5mil (0.09mm)	
2oz Copper weight	8mil (0.2mm)	8mil (0.2mm)	

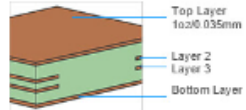
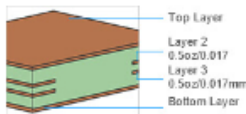
Figure IV. 6 Minimum Trace Width and Spacing

IV.2.2 Design Software Tools

In the PCB design process, utilizing the right software tools is essential for creating precise and efficient designs. Here are two platforms we used in this project:

IV.2.2.1 EasyEDA: EasyEDA is a user-friendly, web-based EDA tool suite which integrates powerful schematic capture, PCB layout, and library management capabilities. It allows designers to create complex PCBs Figure IV. 7 with ease and provides real-time collaboration features[37].



Improve Design Efficiency in Business and Accelerate Innovation

The world's first EDA software vendor with a full supply chain solution

Figure IV. 7 EasyEDA Homepage[37].

Chapter IV: Implementation of Drone Systems through PCB Design

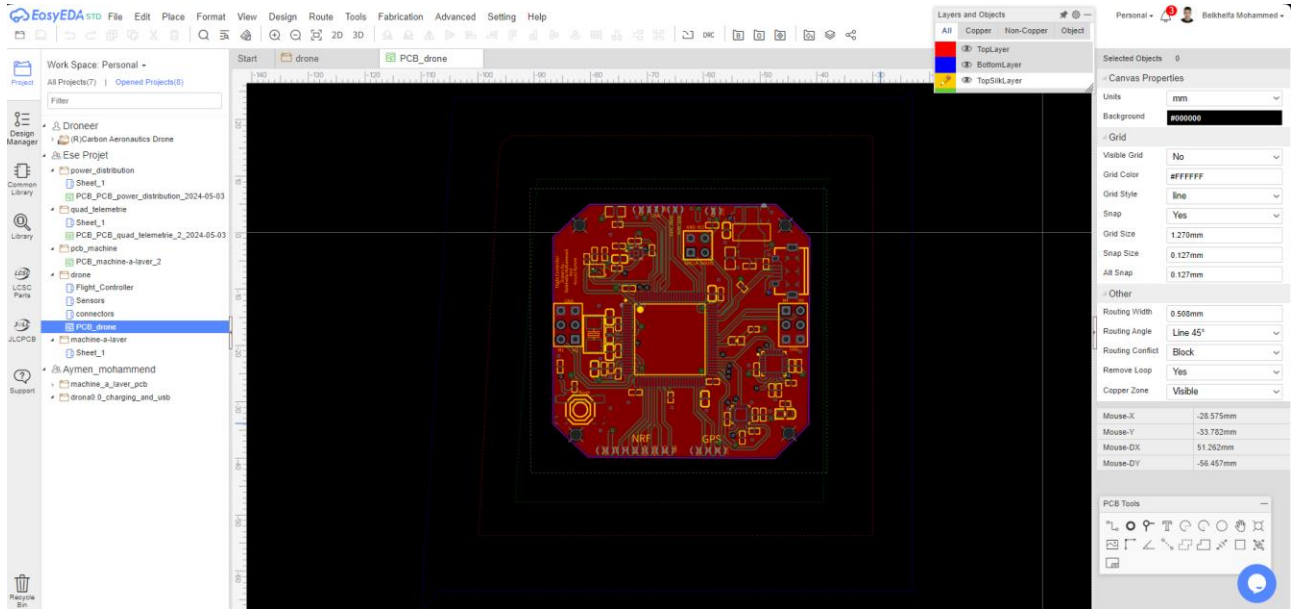

Figure IV. 8 EasyEDA PCB Design Workspace[37].

- **Schematic Capture:** EasyEDA allows for intuitive schematic design, enabling seamless integration of various components.
- **PCB Layout:** The tool offers advanced routing features, including multi-layer design and component placement optimization.
- **Simulation:** EasyEDA includes simulation capabilities to test circuit designs before moving to production.

IV.2.2.2 JLCPCB: JLCPCB is a leading PCB manufacturing and assembly platform that offers high-quality and cost-effective services [38].

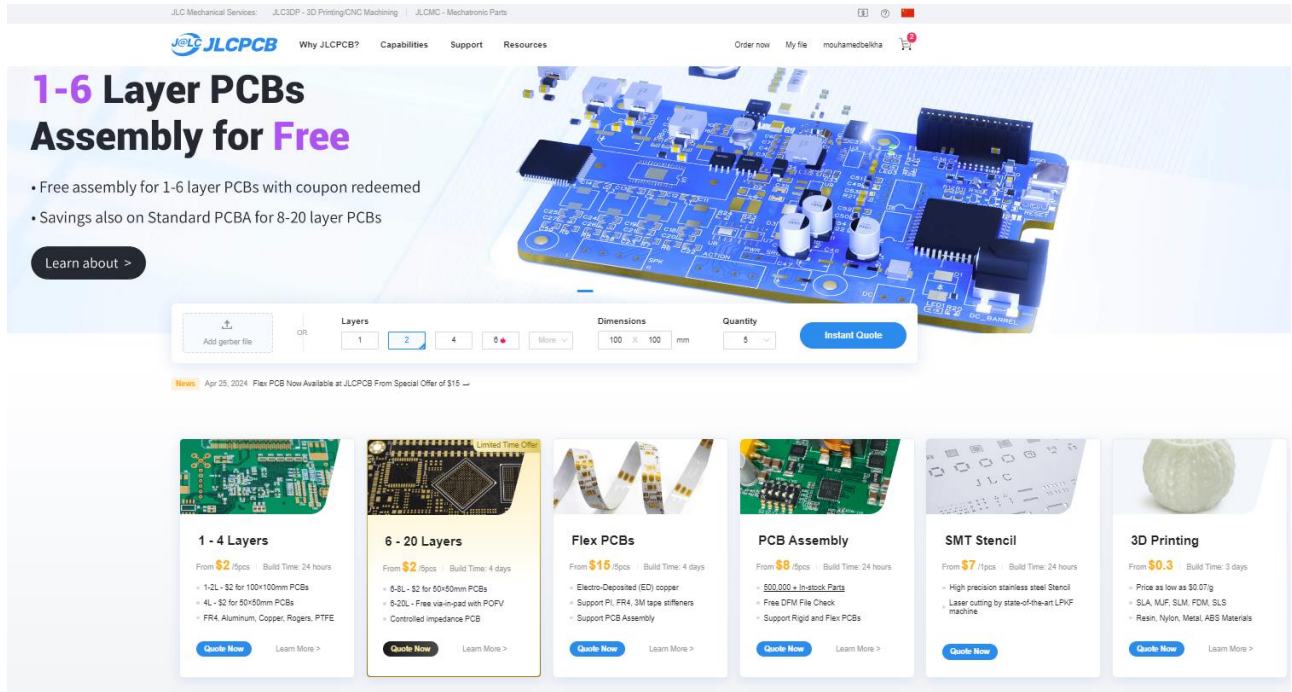

Figure IV. 9 JLCPCB Homepage[38]

- **PCB Manufacturing:** JLCPCB provides quick turnaround times and precise manufacturing for various PCB types, ensuring high-quality production.
- **Assembly Services:** The platform offers comprehensive PCB assembly services, including component sourcing, soldering, and quality inspection, ensuring that the final product meets design specifications.
- **Integration with EasyEDA:** EasyEDA projects can be directly transferred to JLCPCB for manufacturing and assembly, streamlining the process from design to production.

IV.2.3 Design Requirements

Each type of PCB in a drone has specific design requirements to ensure functionality and durability in various operating conditions:

IV.2.3.1 Flight Controller PCB

- **Vibration Resistance:** Must withstand high levels of vibration during flight. Use of shock-absorbing mounts and vibration-resistant components is crucial.
- **Signal Integrity:** High signal integrity is necessary to process sensor data accurately and control the drone's movements.

IV.2.3.2 Remote Control PCB

- **Communication Reliability:** Must ensure stable and long-range communication between the drone and the controller.
- **Ergonomics:** The design should consider the physical layout for user comfort and ease of use.
- **Durability:** Needs to be robust to handle drops and rough usage during field operations.

IV.2.3.3 Power Distribution PCB

- **Power Handling:** Must efficiently manage and distribute power to various components, ensuring stable operation.
- **Thermal Management:** Effective dissipation of heat generated by power components to prevent overheating.
- **Size and Weight:** Should be designed to be lightweight and compact, as drones often have strict weight limitations to optimize flight performance.

IV.3 Holistic Drone System Schematic Design

IV. 3.1 Flight Controller schematic Design

IV. 3.1.1 Circuit Design

The flight controller circuit design includes various critical components and subsystems to ensure optimal performance and reliability. The design incorporates the following elements:

A. Microcontrollers:

- The microcontroller is connected to various peripherals through its GPIO pins, SPI, I2C, UART, and CAN interfaces. It is powered by a 3.3V supply provided by the AMS1117-3.3 voltage regulator.

Chapter IV: Implementation of Drone Systems through PCB Design

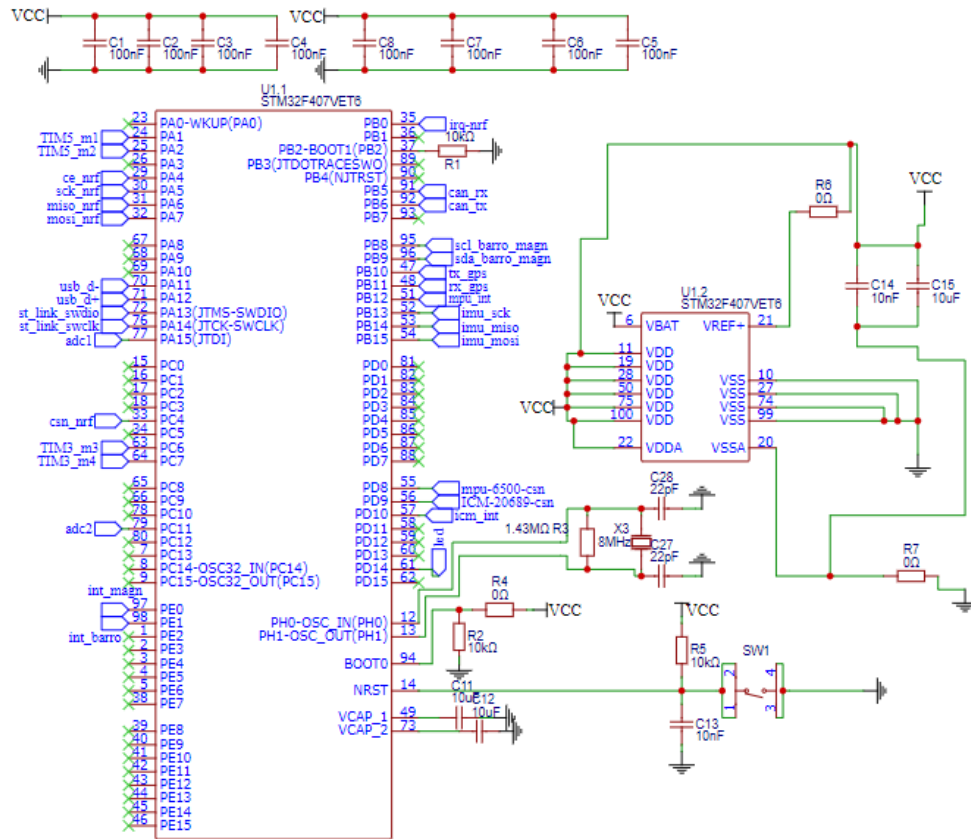

Figure IV. 10 STM32F407VET6 Microcontroller Schematic Diagram

B. Sensors:

- **MPU6500:** This sensor provides gyroscope and accelerometer data. It is crucial for measuring the drone's orientation and movement. The sensor communicates with the microcontroller via SPI.

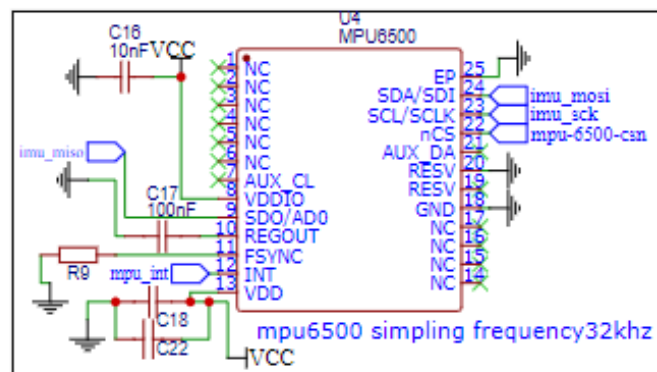

Figure IV. 11 MPU6500 Sensor Schematic Diagram

Chapter IV: Implementation of Drone Systems through PCB Design

- **ICM-20689:** Another gyroscope and accelerometer module that offers high-precision data for accurate flight control. It also uses SPI for communication.

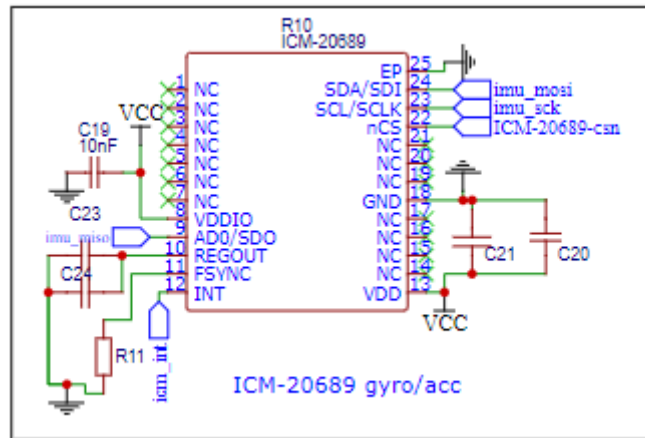

Figure IV. 12 ICM-20689 Gyro/Acc Schematic Diagram

- **SPL06-001:** A barometric pressure sensor used to measure atmospheric pressure, aiding in altitude determination. The sensor interfaces with the microcontroller using I2C.

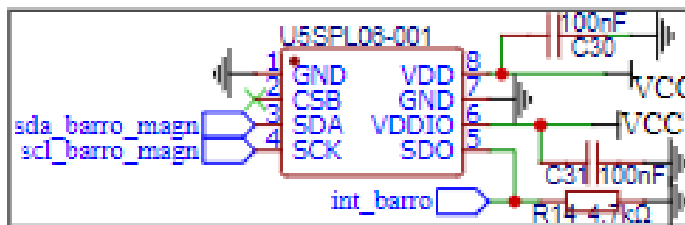

Figure IV. 13 SPL06-001 Barometric Pressure Sensor Schematic Diagram

- **BM1422AGMV-ZE2:** A magnetometer that provides directional heading information to the flight controller, connected via I2C.

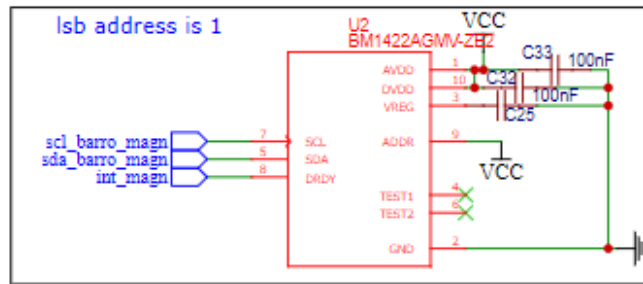

Figure IV. 14 BM1422AGMV Magnetometer Schematic Diagram

- **GPS Module (WP9):** Connected via UART, this module provides real-time location data for navigation and positioning. The GPS module's TX and RX lines are connected to the microcontroller's UART interface.



Figure IV. 15 GPS Module Schematic Diagram

- **NRF24L01+PA+LNA(WP1):** The NRF24L01 module is connected to the microcontroller via SPI.

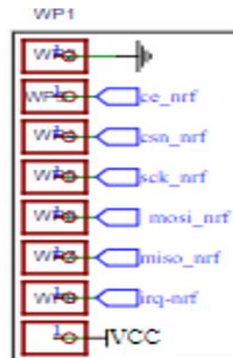

Figure IV. 16 nRF24L01+ Module Schematic Diagram

C. Connectivity Features:

- **USB Interface (USB1):** Includes a USB-to-UART bridge for communication and firmware updates, connected through resistors and capacitors for signal integrity. The USB interface allows for easy firmware updates and debugging.

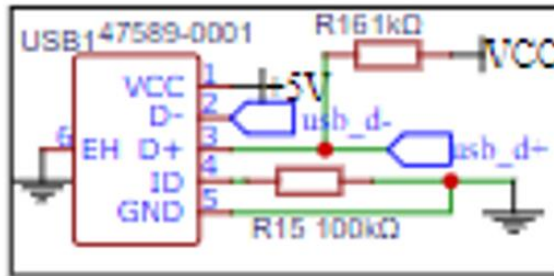

Figure IV. 17 USB Interface Circuit Schematic Diagram

- **ST-Link (H1):** A debugging interface that allows for programming and debugging the STM32 microcontroller. The SWDIO and SWCLK lines connect to the microcontroller's SWD interface.

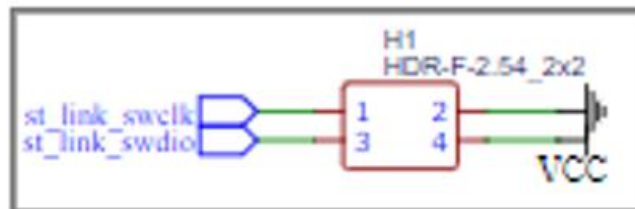

Figure IV. 18 ST-Link SWD Interface Schematic Diagram

- **SPI/I2C:** Used for communication with various sensors and peripherals. The design includes headers for SPI and I2C connections.
- **CAN Module (WP11):** The MCP2515 CAN controller is used for robust communication with other CAN-enabled devices, connected via SPI to the microcontroller.

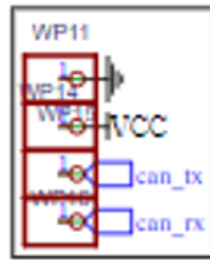

Figure IV. 19 CAN nterface Schematic Diagram

- **UART:** Utilized for serial communication with GPS and telemetry modules, ensuring reliable data exchange.

D. Power Management:

- **AMS1117-3.3 Voltage Regulator (UE):** Ensures a stable 3.3V supply to the microcontroller and other components. It includes capacitors for filtering and stability.

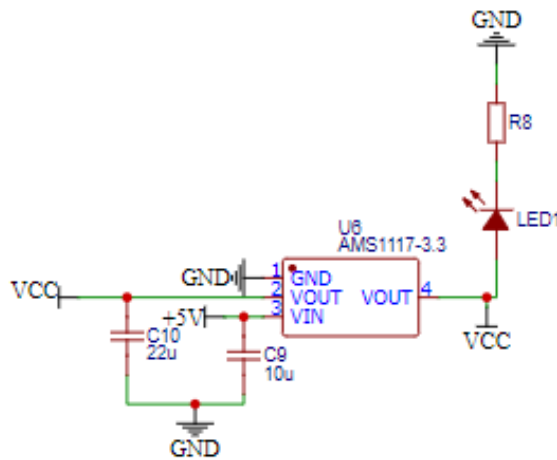

Figure IV. 20 Voltage Regulator with LED Indicator Schematic Diagram

- **Power Distribution:** Various decoupling capacitors are placed near the power pins of the microcontroller and sensors to ensure clean power delivery and minimize noise.

IV. 3.1.2 PCB Layout

The PCB layout is meticulously designed to ensure minimal interference and optimal performance.

Key considerations include:

A. Component Placement:

- The microcontroller (U1) is centrally located to minimize trace lengths for critical signals and ensure efficient layout.
- Sensors (MPU6500, ICM-20689, SPL06-001, BM1422AGMV-ZE2) are placed strategically to balance the board and reduce signal interference.
- Connectors and interfaces are placed at the edges for easy access and connectivity during assembly and use.

B. Layer Stackup:

- The PCB design uses a multi-layer stack-up to separate different signal types and provide dedicated power and ground planes, reducing EMI and cross-talk. Typically, a 4-layer stack-up is used with the following arrangement:
 - Top layer: Signal routing
 - Inner layer 1: Ground plane
 - Inner layer 2: Power plane
 - Bottom layer: Signal routing

C. Grounding and Shielding:

- Proper grounding techniques are used to minimize noise and ensure stable operation of sensitive components.
- Ground fills and stitching vias are employed to connect different ground planes and provide a low-impedance path for return currents.

IV. 3.2 Remote Control schematic Design

IV. 3.2.1 Circuit Design

The circuit design of the remote control includes several key components and modules:

- **Microcontroller:**

Chapter IV: Implementation of Drone Systems through PCB Design

- **STM32F103C8T6:** The microcontroller is the heart of the remote control, managing inputs from buttons and the joystick, processing data, and handling communication with the drone.

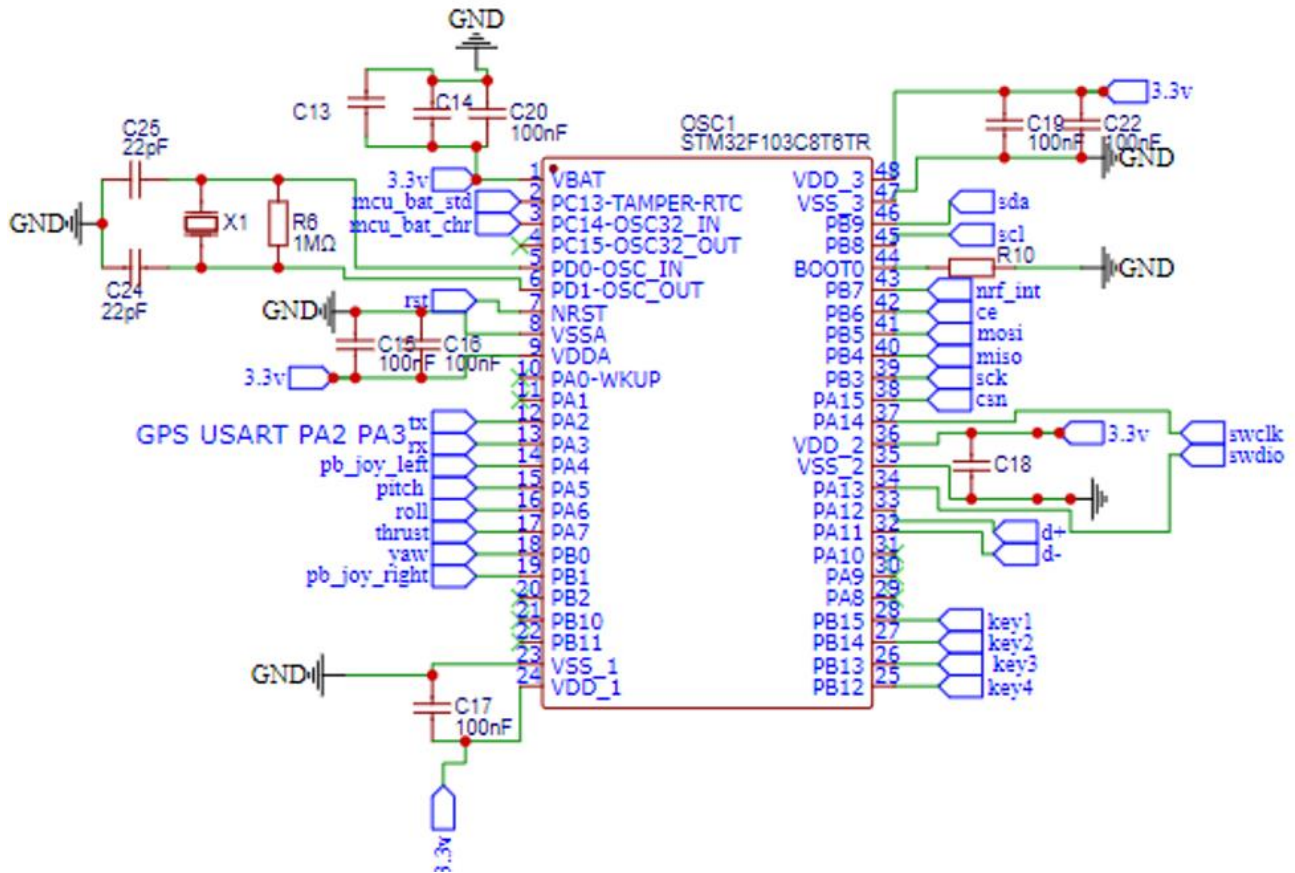

Figure IV. 21 STM32F103C8T6 Microcontroller Schematic Diagram

IV. 3.2.2 Communication Modules

- **NRF24L01+PA+LNA:** This RF module is used for wireless communication between the remote control and the drone. It operates on the 2.4GHz band and provides robust and reliable communication.

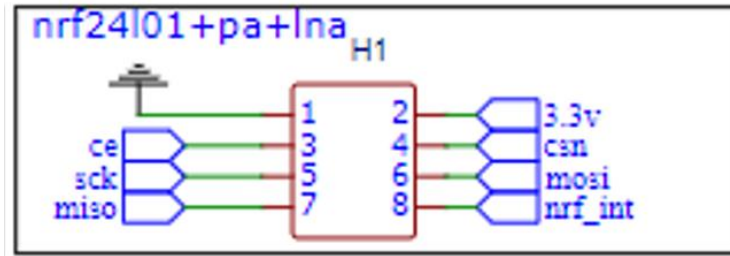

Figure IV. 22 nRF24L01+ PA+LNA Module Schematic Diagram

IV. 3.2.3 Power Supply

- The remote control is powered by a battery. The power management circuit includes a battery charger based on the TP4056, a boost converter based on the MT3608, and a power path switch using the AOA1041A.
- **AMS1117-3.3:** A voltage regulator that ensures a stable 3.3V supply for the microcontroller and other components.

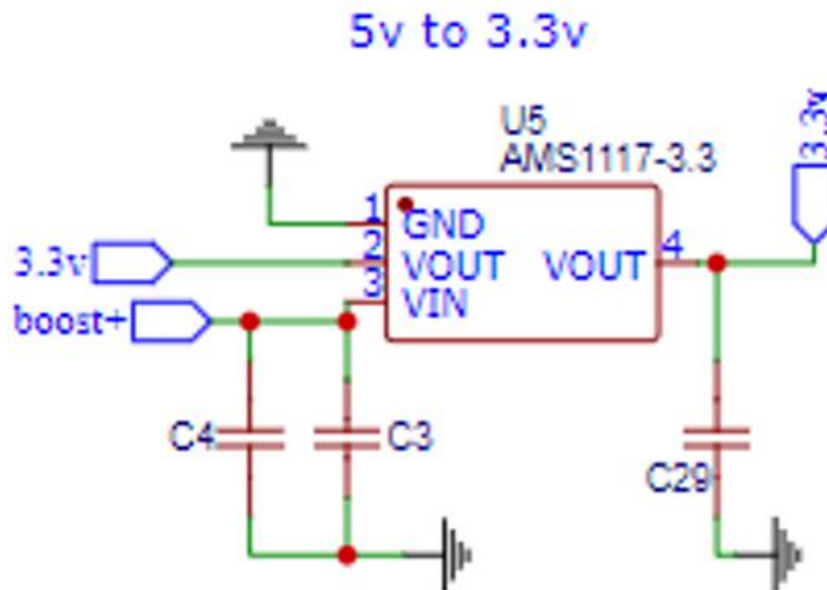

Figure IV. 23 5V to 3.3V Voltage Regulator Schematic Diagram

IV. 3.2.4 User Interface Components

- **Buttons:** Several push buttons are included for user inputs. These are connected to the GPIO pins of the microcontroller.

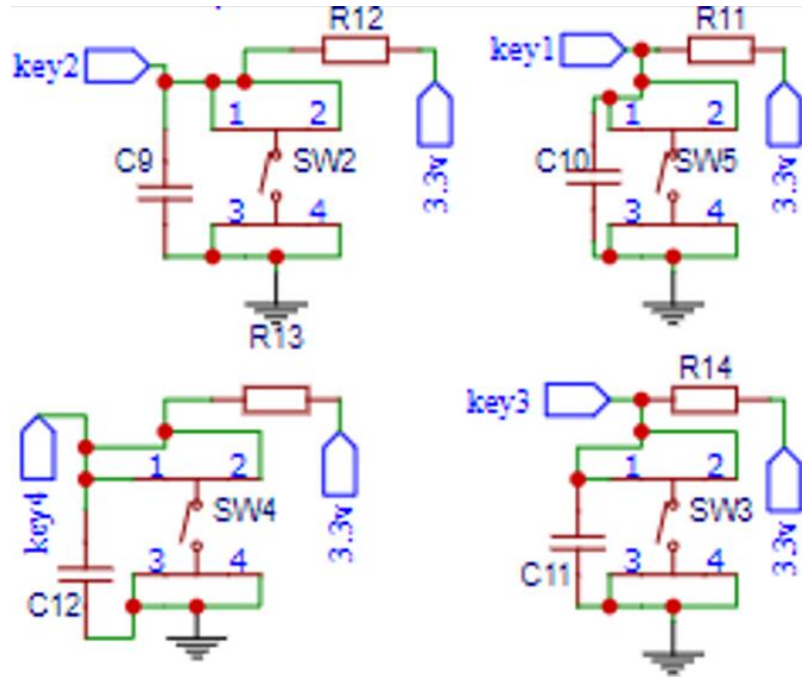

Figure IV. 24 buttons Schematic Diagram

- **Joystick:** The joystick module provides analog inputs for precise control of the drone. It is connected to the ADC pins of the microcontroller.

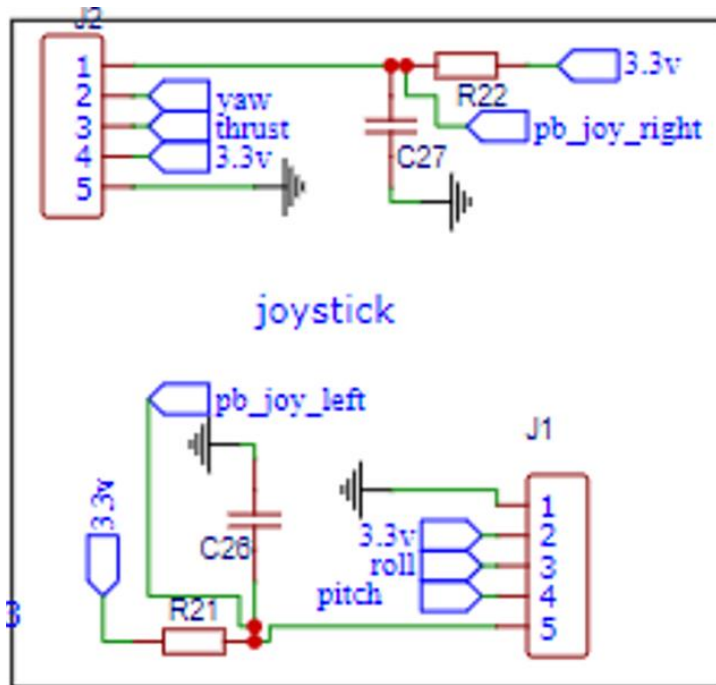

Figure IV. 25 Joystick Interface Schematic Diagram

- **OLED Display:** A 0.96-inch OLED display is included for visual feedback, showing information such as battery status, connection status, and flight data.

lcd OLED 0.96 I2C

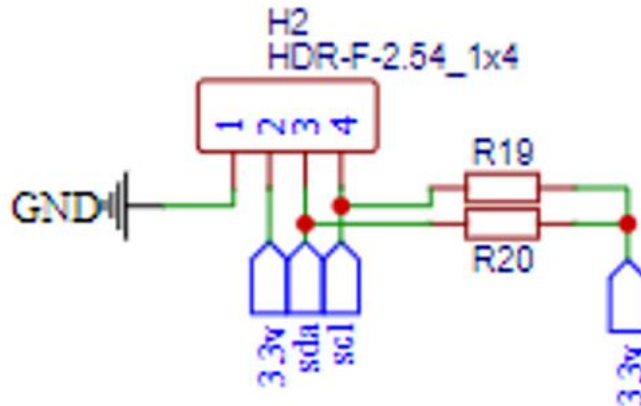

Figure IV. 26 OLED Display Interface Schematic Diagram

IV. 3.2.5 PCB Layout and Fabrication

- Component Placement:

- The microcontroller is placed centrally to allow easy routing of connections to other components.
- The NRF module is placed away from other high-frequency components to avoid interference.
- Decoupling capacitors are placed close to the power pins of the microcontroller and RF module to ensure stable power delivery.

IV. 3.2.6 Challenges Faced During Fabrication:

- **Signal Integrity:** Ensuring that the high-speed SPI signals to the NRF24L01 module were properly routed and had controlled impedance to prevent signal integrity issues.
- **Power Distribution:** Designing the power management circuit to handle the varying power requirements of different modules while maintaining a stable voltage.
- **Component Placement:** Balancing the placement of components to avoid interference while maintaining an ergonomic design.

IV. 3.3 Power Distribution System Schematic Design

IV.3.3.1 Circuit Design

The circuit design of the power distribution PCB focuses on efficient power conversion, regulation, and monitoring. The main components and their functions are as follows:

A. Voltage Regulators:

- **Buck Converter (XL1509-5.0E1):** This component steps down the battery voltage to a stable 5V output, which is used to power various 5V components and serve as an input to further regulation.
 - It includes an inductor, diode, and capacitors to ensure smooth voltage conversion with minimal ripple.

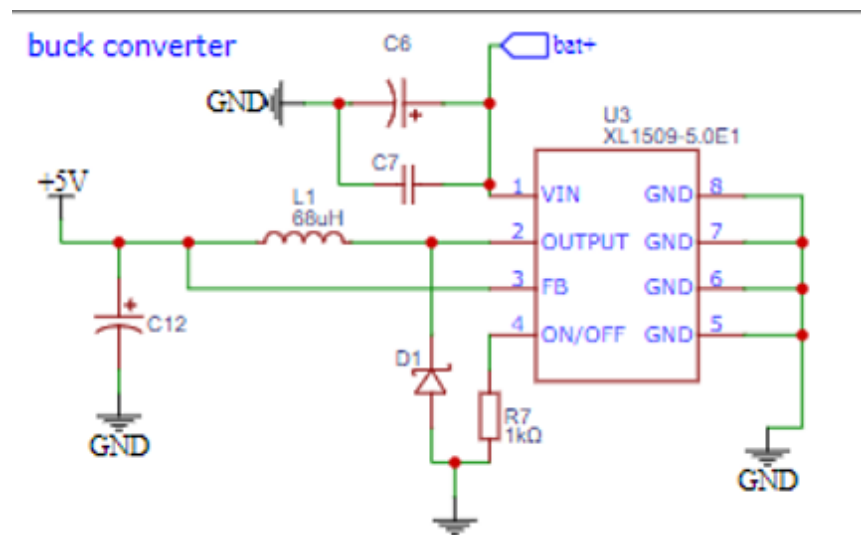

Figure IV. 27 Buck Converter Schematic Diagram

- **3.3V LDO Regulator (AMS1117-3.3):** This linear regulator takes the 5V output from the buck converter and provides a stable 3.3V output, which is essential for sensitive components like the microcontroller and sensors.

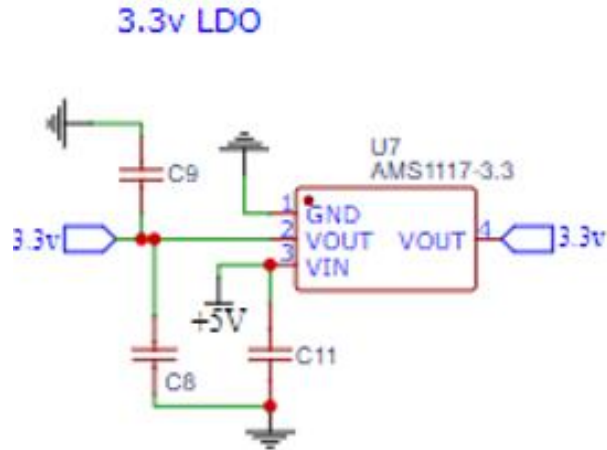

Figure IV. 28 3.3V LDO Regulator Schematic Diagram

B. Capacitors:

- Various capacitors are used throughout the circuit for decoupling and filtering. They help smooth out voltage fluctuations and provide stable power to the components.
- Capacitors are placed close to the power pins of ICs and other critical components to reduce noise and ensure reliable operation.

C. Power MOSFETs:

- Power MOSFETs are used to switch high currents required by the motors. They provide efficient control over the power delivery, ensuring minimal losses and heat generation.
- The MOSFETs are controlled by the microcontroller, enabling precise power management and protection mechanisms.

D. Current and Voltage Sensing:

- **Shunt Resistor and Current Sensor (INA219):** This setup is used to measure the current flowing through the circuit, providing real-time monitoring of power consumption.

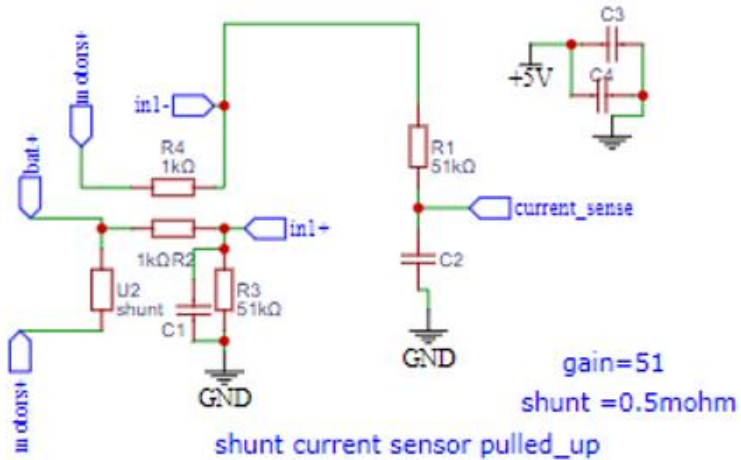

Figure IV. 29 Shunt Current Sensor Circuit Schematic Diagram

- **Voltage Divider and ADC:** The voltage across the battery is monitored using a voltage divider and fed into an ADC pin on the microcontroller. This allows for continuous monitoring of battery health and capacity.

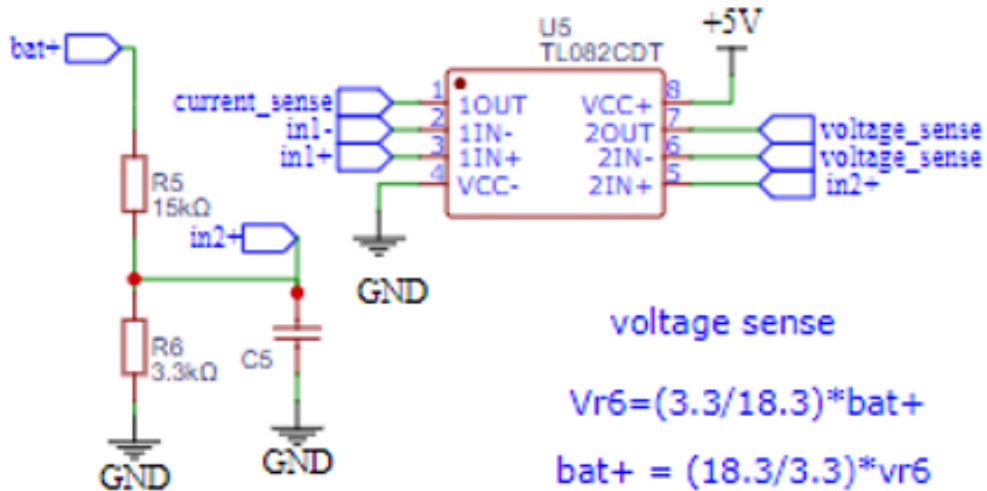

Figure IV. 30 Voltage Sensing Circuit Schematic Diagram

IV. 3.4 Detailed Diagrams of Schematics

IV.3.4.1 Flight Controller

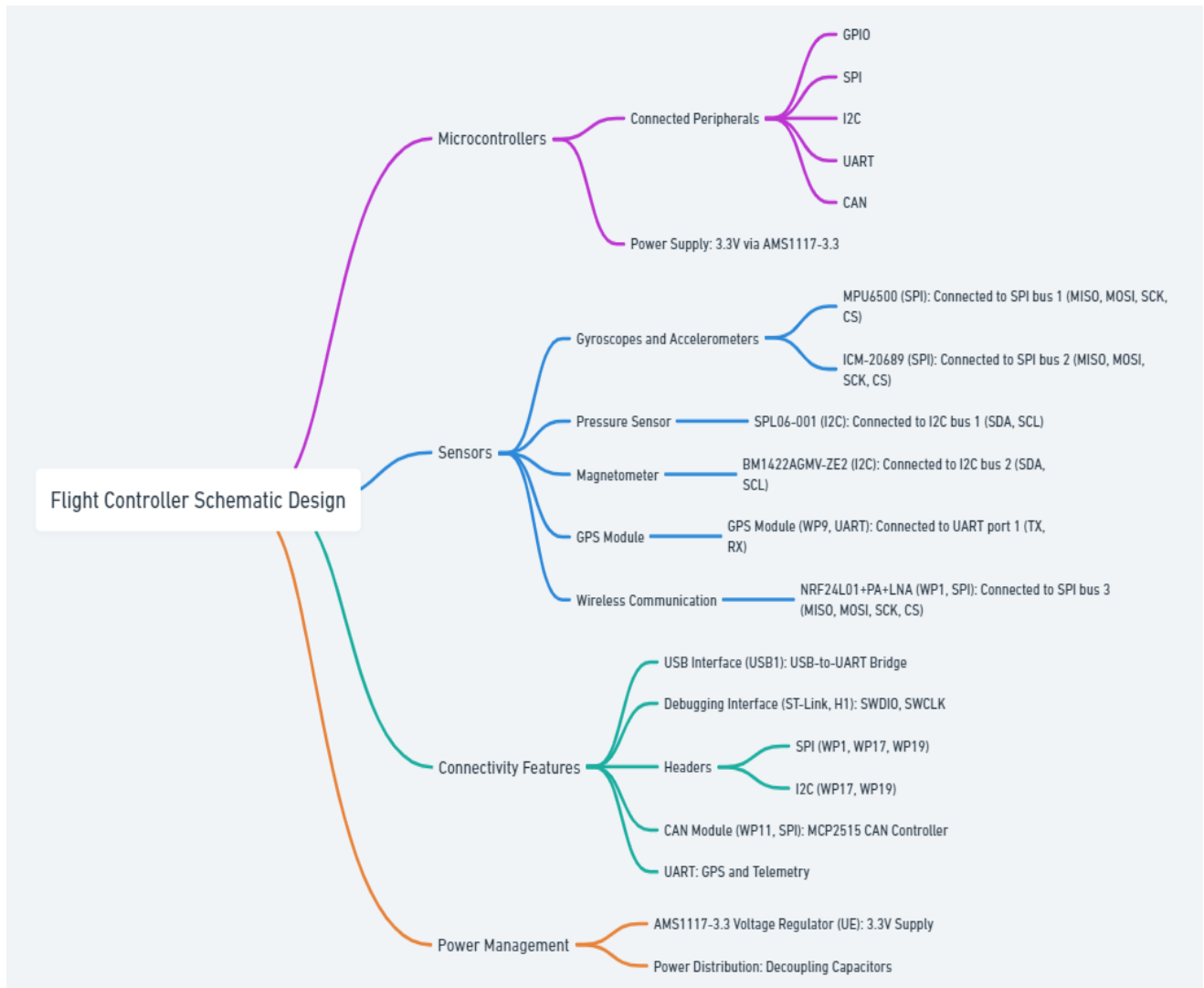

Figure IV. 31 Flight Controller Diagram

IV.3.4.2 Remote Control

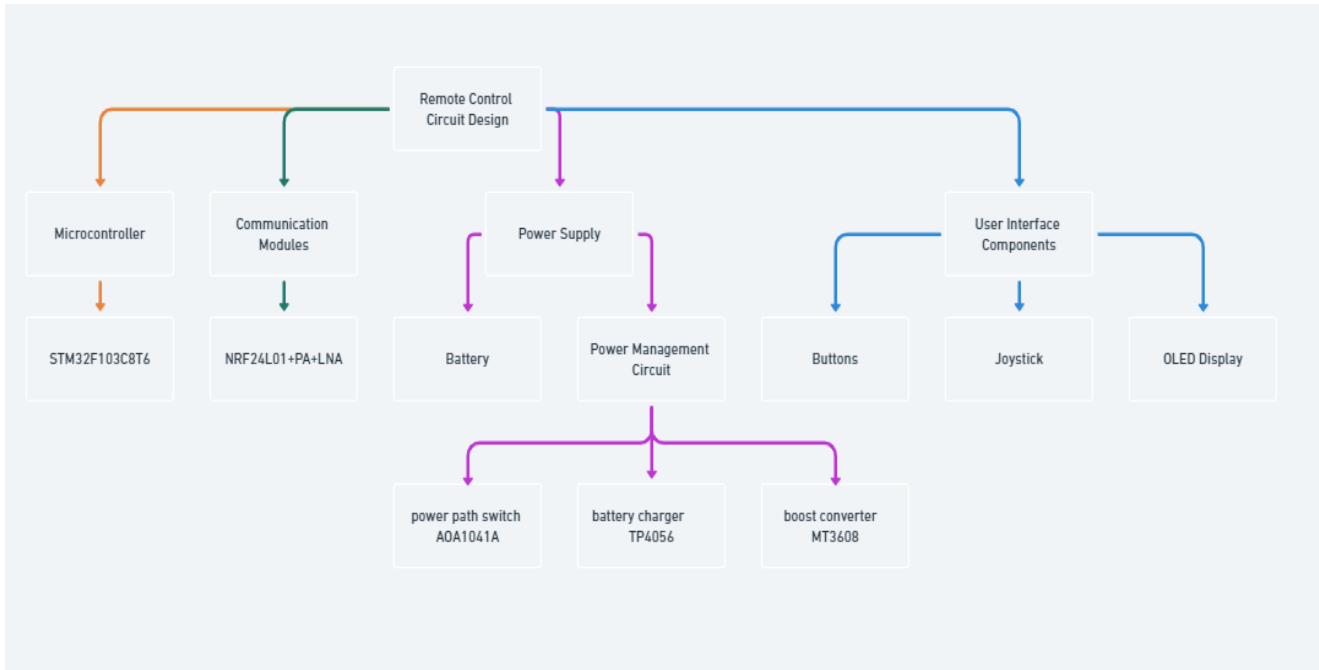

Figure IV. 32 Remote control Diagram

IV.3.4.3 Power Distribution System

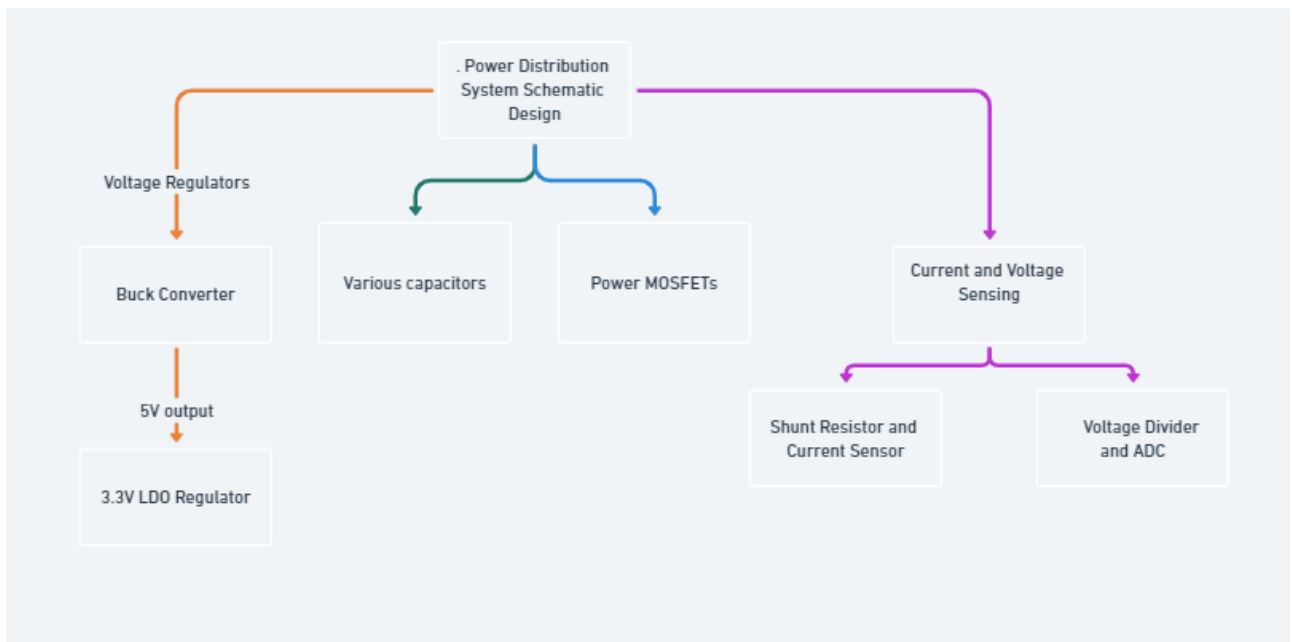

Figure IV. 33 Power distribution Diagram

IV. 3.5 Final Pcb's Design

IV.3.5.1 Pcb Flight controller

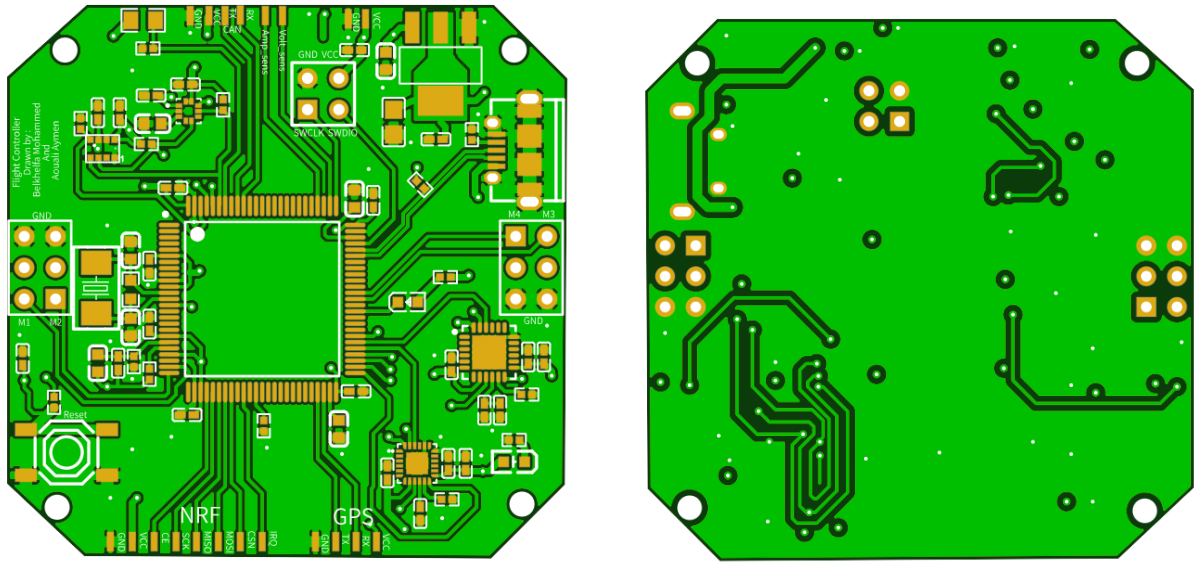

Figure IV. 34 2D Pcb flight Controller Top and Bottom View

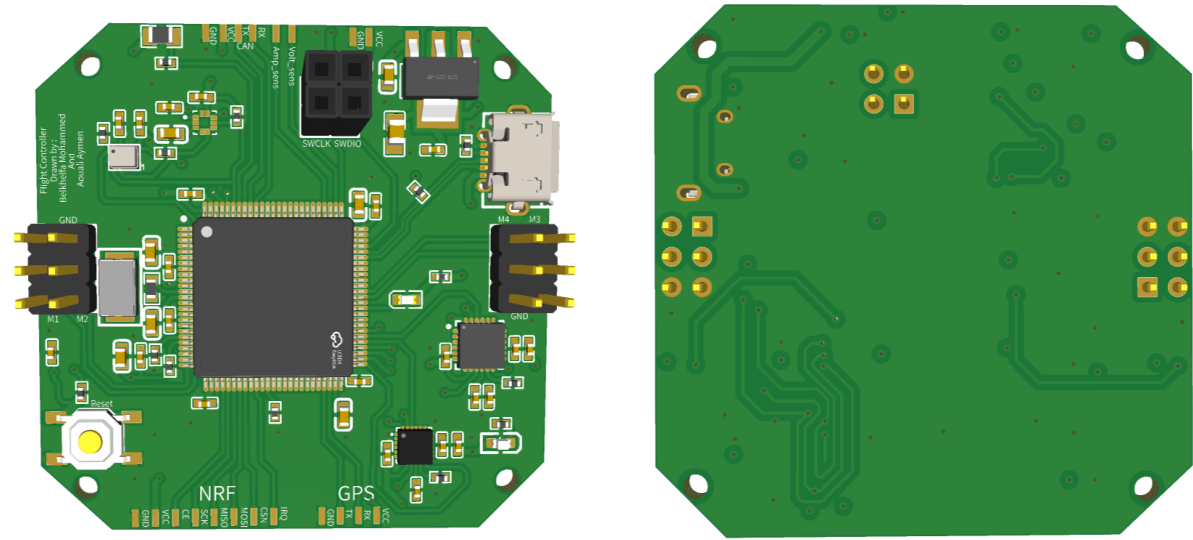

Figure IV. 35 3D Pcb flight controller Top And Bottom View

IV.3.5.2 Pcb Remote control

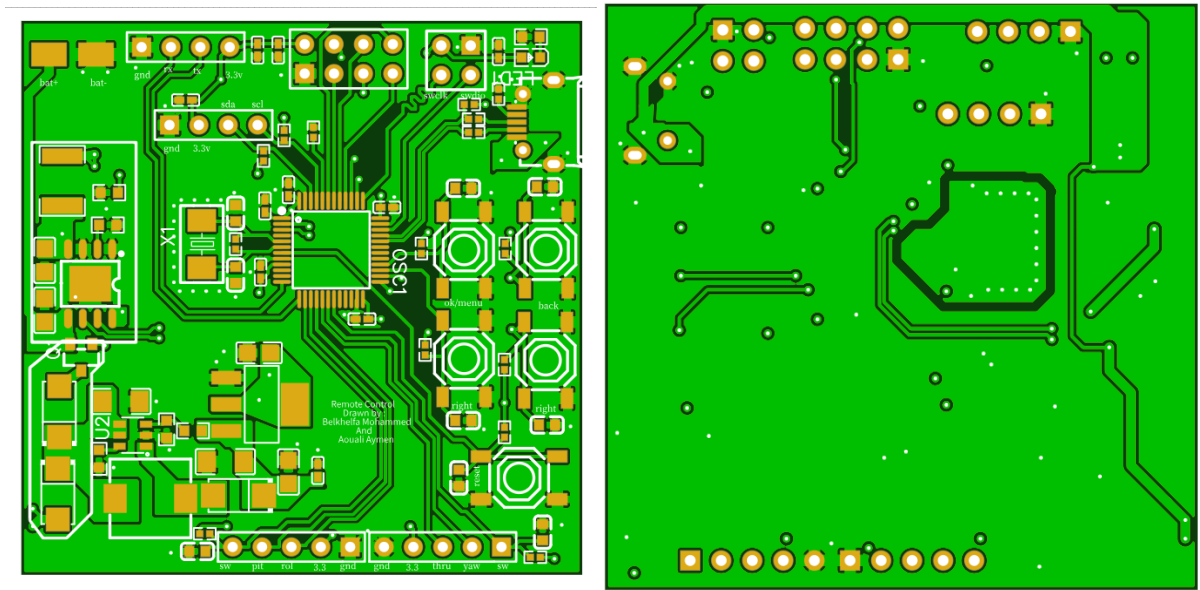

Figure IV. 36 2D Pcb Remote control Top And Bottom View

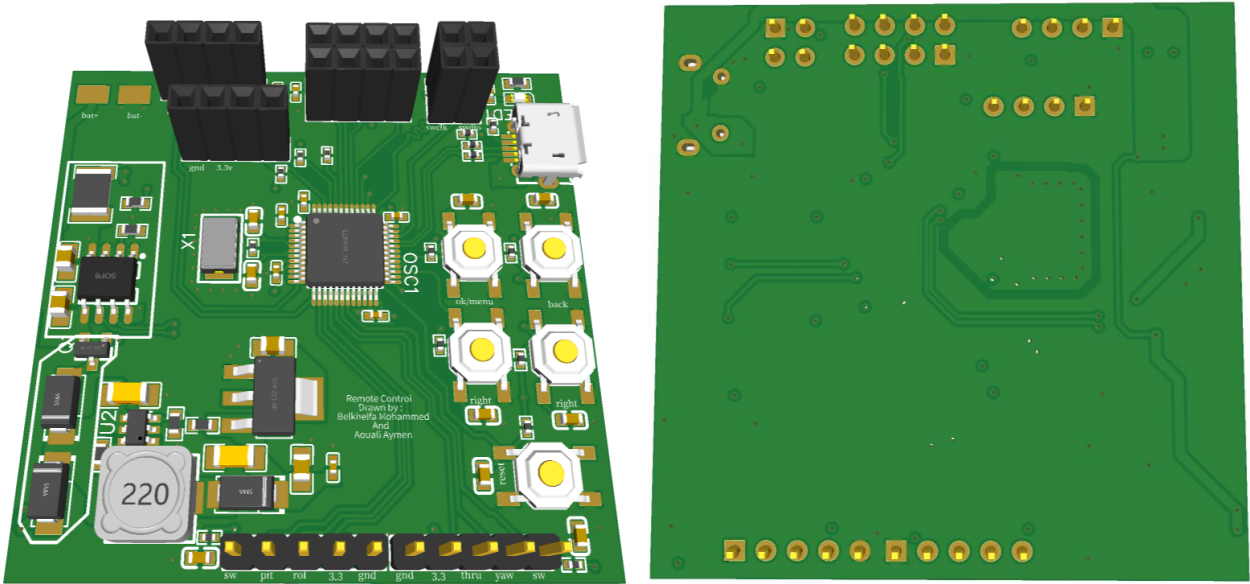

Figure IV. 37 3D Pcb Remote control Top And Bottom View

IV.3.5.3 Pcb Power distribution

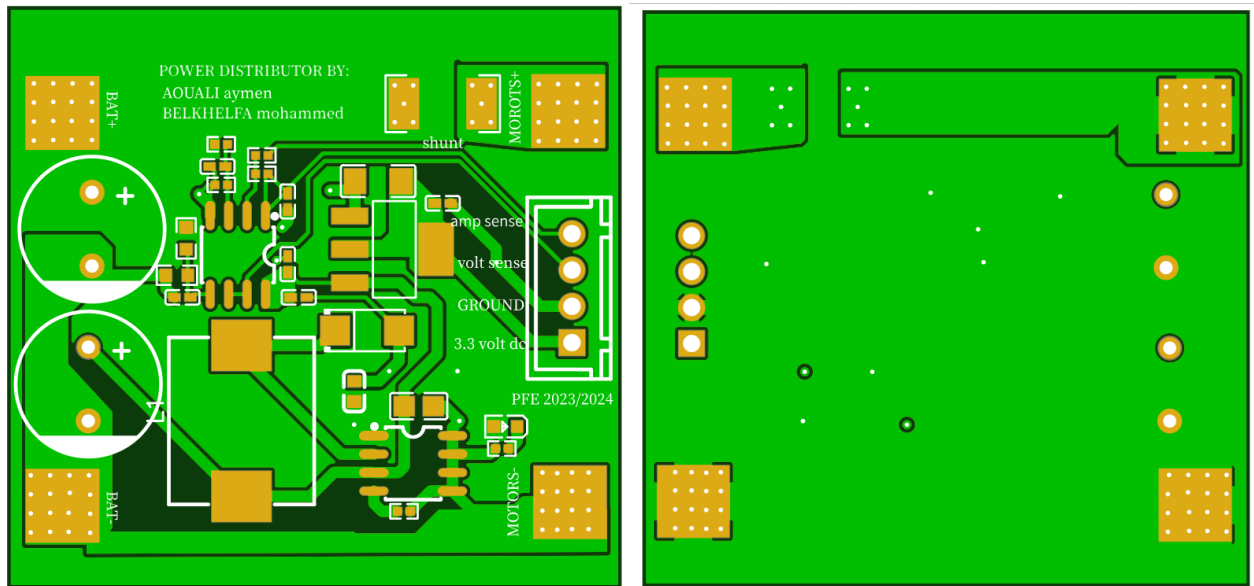

Figure IV. 38 2D Pcb Power distribution Top And Bottom View

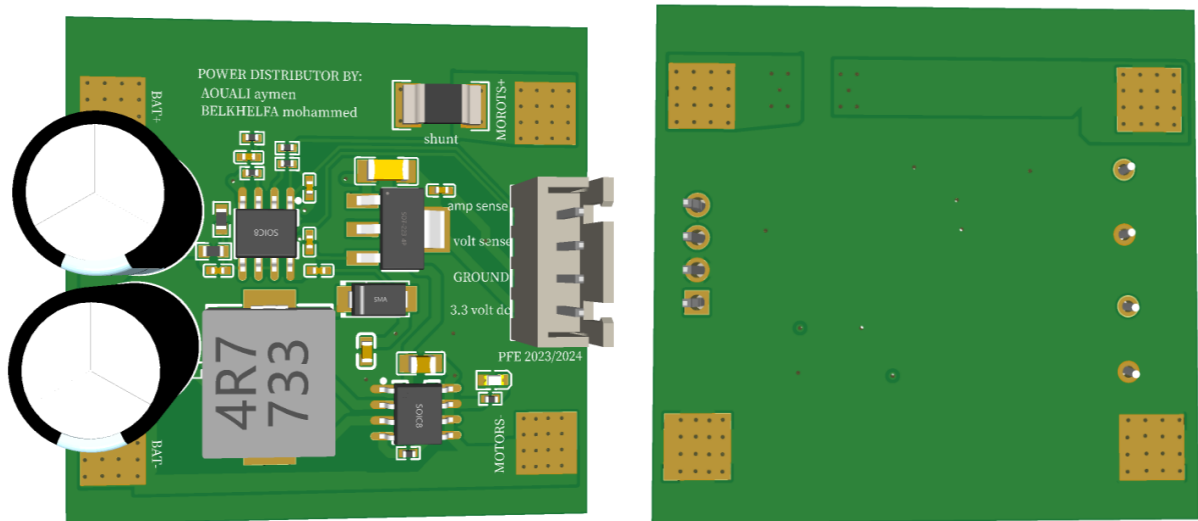

Figure IV. 39 3D Pcb Power distribution Top And Bottom View

IV.4 Programming language and tools

To program stm32 we have use stm32cube IDE who is developed by ST microelectronic, this software support C/C++ languages and many other tools that are powerful in build and testing that help to decrease system development life cycle, here we will try to show you the main tools supported by stm32cube IDE:

Chapter IV: Implementation of Drone Systems through PCB Design

-Cube MX: it's a software integrated in stm32cube IDE allow the graphical configuration of peripherals, clock control, MCU pin out and NVIC units and other parameter like sleep mode and adding middleware. At the end of configuration cube mx can generate C/C++ code based on HAL libraries that we will explain in the next title.

-HAL libraries (hardware abstraction layer): these libraries hide the complex side stm32 programing by delivering a set of functions make access to peripherals so easy and without use of delay inside.

- **DEBUG:** stm32cube IDE support debugging, this tool is very helpful in testing and code correction, but unfortunately, cube IDE do not support simulation debug, so we need to place MCU on computer for debugging.

- **Live expression viewer:** this tool work in debug mode, it gives us chance to view code variables in real time.

- **Register viewer:** it shows all stm32 registers, but unlike live expression viewer, it is accessible only when we stop at break point or in step-by-step execution.

We should note the stm32cube IDE allow software transfer and debug with SWD (serial wire debug) or JTAG (Joint Test Action Group) protocols found in ST-LINK dangle that work as bridge between MCU and cube IDE. In addition, we can upload software to MCU by using USB, USART, I2C or SPI peripherals via DFU mode (direct firmware update), because stm32 has originally build in boot loader, this type of code transfer need firstly stm32cube IDE to make hex file, then copy it into stm32cube programmer to transfer it.

Chapter IV: Implementation of Drone Systems through PCB Design

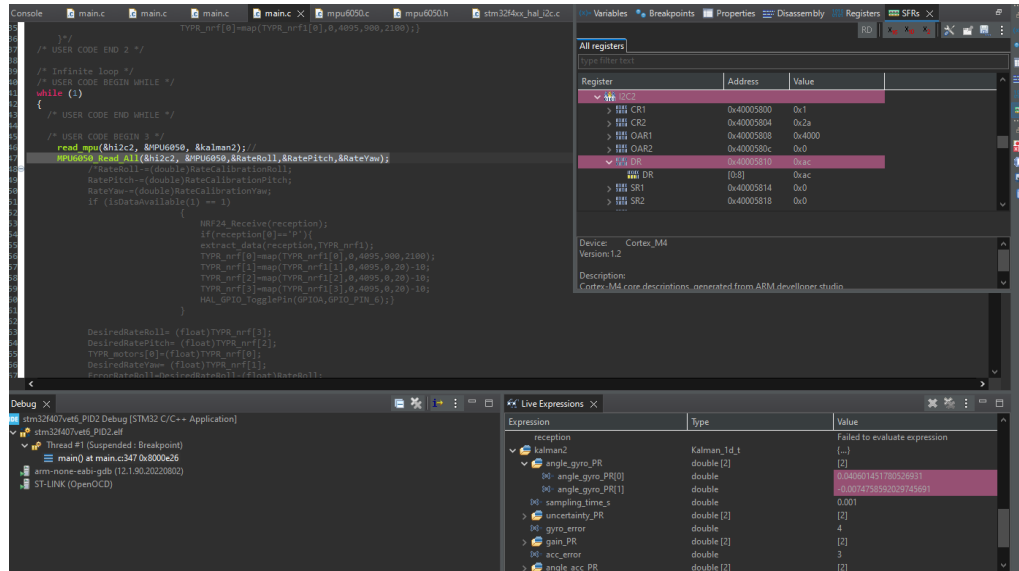

Debug+live expression viewer + register viewer

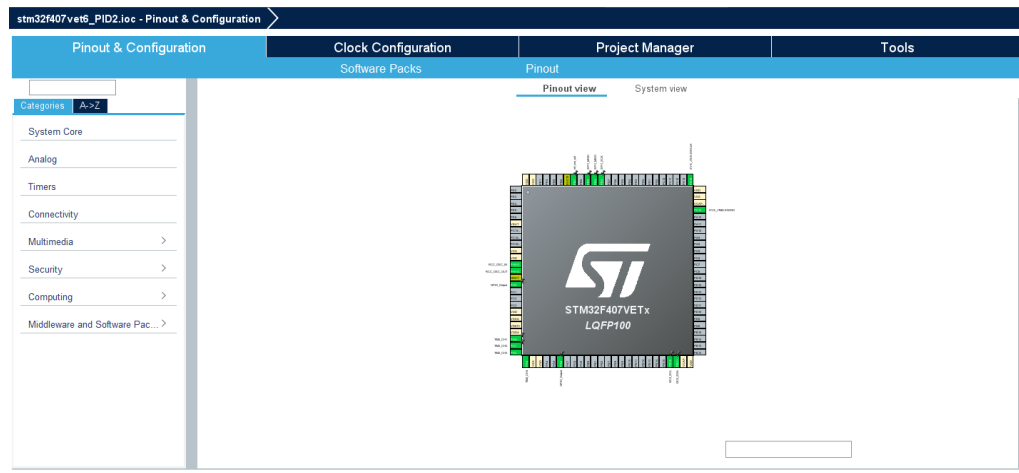

Cube MX

[37].

IV.5 Accessing to sensors, actuators, and communication ICs

Stm32 communicate to other circuit with many protocols and peripherals including I2C, SPI, UART, TIMERS, USB and ADC, here we take each one of them and show where we used it:

IV.5.1 SPI: STM32's SPI support Motorola mode which is the old version of SPI and the most common use, or TI mode who is developed by Texas Instrument with maximum data rate up to 42Mbit/s (for stm32f4 series), also it supports CRC mode (check wrong message) (37). In our case we used Motorola full duplex master MSB first software chip select mode to work with NRF24L01, MPU6500 and ICM-20689, we program these circuits with a set

Chapter IV: Implementation of Drone Systems through PCB Design

of functions based on two main functions HAL_SPI_Transmit () and HAL_SPI_Receive (). here is how these circuit are configured:

A. NRF24L01: this wireless communication circuit support until 10Mhz of SPI clock, so we have chosen a value close to this frequency to allow fast read and write packets, a set of functions based on HAL libraries make interaction with NRF24 easy. In addition, we have made our special data packets to share information between remote control and flight controller. Here function utilized to work with NRF24:

```
NRF24_Transmit(packet);
NRF24_Init ();
NRF24_TxMode(receiver address, 110); // channel 2.4+0.11=2.51Ghz
NRF24_Receive(packet);
isDataAvailable() ;
NRF24_RxMode(my address, 110);
```

- Our protocol:

according to the NRF24L01 datasheet this circuit has a special protocol known as enhanced shock burst to ensure message transfer. In below we will show you the nrf24l01 packet:

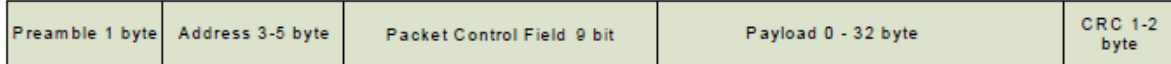

Such that:

Preamble: it define the low and high level.

Address: represent the destination address.

Packet control field: it define the payload length and number of retransmit packet in case when we use acknowledgment mode and the last bit of this part is the acknowledgment request.

Payload: is the part that contain data (size: 32 byte).

CRC code check: to check if the transmission bytes are correct or no.

Unfortunately, with all of these parts we had a problem with noise so we decide to make our packet inside the payload as following:

Code 8bits	Return information 2bits	Data type 2bits	Packet counter 4bits	Bytes to send number 8bits	Data bytes
---------------	-----------------------------	--------------------	----------------------------	----------------------------------	------------

Chapter IV: Implementation of Drone Systems through PCB Design

Code: it's a byte need to match with the receiver code to consider that this packet is true.

Return information: it precise which type of information the flight controller need to return. The returned types is as following:

(00)2: KALMAN pitch and roll angle, and the yaw angle.

(01)2: pitch, and roll, and yaw angle without KALMAN filter.

(10)2: GPS information.

(11)2: PID coefficient information.

Data type: it define the type of data bytes information type:

(00)2: thrust, and pitch, roll, and yaw angle

(01)2: GPS information of the remote control.

(10)2: PID coefficients in case when we use wireless tuning. In our project, we did not reach this step because we need an EEPROM on PCB to store coefficients.

Packets counter: this part resolve the problem of when we send more than 29 bytes, so more than 1 packet of enhanced shock burst.

Data bytes: these bytes contain the information to send.

B. MPU6500/ICM20689: both are gyroscopes and accelerometers sensors, they are the same but differ in few points, we can use SPI or I2C fast mode (400Khz) to communicate with them, but we choose SPI with 1Mhz, here we can view clearly that SPI is two time more rapid than I2C. we should note that 1Mhz frequency is the maximum for reading and writing all MPU6500 register values, in the other hand ICM20689 can reach 8Mhz, so we choose the lower one between them.

IV.5.2 USART: in our project we have utilize USART only for read GPS NEO 6M information, we configure this peripheral in asynchronous mode with 8 bit of data and 1 stop bit without parity check at 9600bit/s. the main HAL function that support USART are HAL_UART_Transmit_IT () and HAL_UART_Receive_IT () for interrupt mode.

- **GPS NEO 6M:** it gives us automatically without any configuration information about altitude, latitude, longitude and time, this information is encoded in ENMA protocol (National Marine Electronics Association), so we have used some functions to extract those information and HAL_UART_Receive_IT (). It is important to declare that only RX pin is active because NEO 6M send data directly. Here are GPS used functions:

```
GPS_Init(); // to enable UART RX interrupt
GPS_UART_CallBack();//extract data from received packet in the RX //interrupt call back
```

IV.5.3 TIMERS: stm32 support 3 types of timers, but we work with one type named “general purpose timer”, each timer can deliver up to four PWM channel and that is very helpful to control all quad copter ESC driver with one timer. To start PWM signal for a specific channel we use this function:

```
HAL_TIM_PWM_Start(&htim2,TIM_CHANNEL number);
```

- **ESC drivers:** ESC that we used are controlled by standard PWM (50 Hz), since the control command is found on Ton (signal high-level time), we must note that Ton exist in range of 1ms to 2ms and represent the maximum and low speed, so we have configured timer to work in these range. Ton is changed by changing CCRx register.

IV.5.4 ADC: in general, stm32 MCUs has more than one SAR type ADC, since each one of them contain many channels up to 16, these channels can be converted continuously by enabling scan mode and continuous conversion mode. In addition, we can enable DMA to transfer converted channels directly to a specific location in SRAM. It important to declare that stm32 contain ADC channels for read internal temperature sensors, VREF (to check accuracy of ADC or the drift error) and VBAT (for small battery used to kip real time clock work if there is no power) values. Some stm32 ADC support only 12-bits conversion and others support many resolutions according to configuration (6, 8, 10 and 12 bits) (37). These are the main ADC HAL functions:

```
HAL_ADC_Start(&hadc1);// it will disable after conversion
HAL_ADC_Start_DMA(&hadc1, TYPR_motor, 4);// at end of conversion it //will start other
conversion and store data in TYPR_motor that is //found in SRAM
```

We have use ADC to read battery voltage and current (in flight controller), and joysticks rotation in remote control with 12 bits resolution.

- Battery voltage and Currant consumption:

Battery status is a critical parameter in drone, to estimate how match more time can fly. For that, our power distribution board give us information about voltage and current, these two values are reading by flight controller’s ADC each 10ms with the following equation:

Chapter IV: Implementation of Drone Systems through PCB Design

$$battery_{current} = \left(\frac{VOLT_{ADC} * 3.3}{4095} \right) * \frac{1000}{25.5} \text{ In ampere.}$$

$$battery_{voltage} = \left(\frac{VOLT_{adc} * 18.3}{4095} \right) \text{ In volt.}$$

We should note that we use a timer back grand to generate interrupt each 1ms for start ADC reading in DMA mode then stop reading and wait another interrupt (10ms). But why 1ms?

It a fixed time value to estimate how more capacity still in battery and it is calculated with this equation:

$$capacity_{new} = capacity_{old} - battery_{current}$$

Such that capacity is converted from AH to Ams, for example:

Battery with 4AH capacity can be transformed to $4A * 3600 * 1000ms$, so, $4AH = 14400000 \text{ Ams}$.

- Joysticks:

this part found on remote control to calculate Joystick's is voltage with ADC in continuous scan DMA mode, then send this value directly to flight controller or used it to manipulate remote control's OLED when we are in configuration mode.

IV.5.5 USB: our remote control's MCU (stm32f103c8t) support full speed USB, so we used it in virtual com mode to send data to computer with the help of USB_DEVICE middleware found in CUBEMX. Here are the most important functions utilize for sending:

```
CDC_Transmit_FS((unsigned char *) buf, (uint16_t) strlen(buf));
```

IV.5.6 I2C: STM32's I2C operate in standard mode (100Khz) and fast mode (400Khz), three main HAL functions support I2C communication as master:

```
HAL_I2C_Master_Transmit();//write with I2C to specific address  
HAL_I2C_Master_Receive();// read I2C data from specific address  
HAL_I2C_Mem_Read() ; // send command to receive data from specific //I2C address
```

In flight controller we have use I2C to read barometer and compass sensors. In remote control it's used to print data on OLED.

- OLED 0.96:

Remote control's OLED is basic on SSD1603 controller, and support only two color black and white. In addition, it uses SPI or I2C as communication protocol according to special pins are pulled-up or down. In our case, it is pre-configured to work with I2C with maximum data rate of 400Kbit/s (I2C fast mode). With the use of library here are the basic function that we use:

```
SSD1306_GotoXY (26,2);// screen pointer go to pixel located in (x,y)
SSD1306_Putc ('T', &Font_11x18, 1);;// print a char
SSD1306_DrawRectangle(5, 22, 54, 10, 1);;//print a rectangle
SSD1306_UpdateScreen();;//print graphical RAM data on screen
```

IV.6 Software development planning

In software development we try always to follow the software development life cycle process (planning, analyze, design, development, testing, maintenance) (38). We should note that our control algorithms tests are based on a quad copter. Here are the cycles that we have passed:

IV.6.1 Testing each circuit independently: the idea is to check if these circuits can work correctly with ARDUINO libraries, if all circuits are good so we can jump to STM microcontroller and test them with stm32 supported libraries, then make a few changes on this lib to adapt with our goals (e.g.: change MPU6500 sampling frequency). Here is the algorithm that we follow with each circuit to finish this cycle:

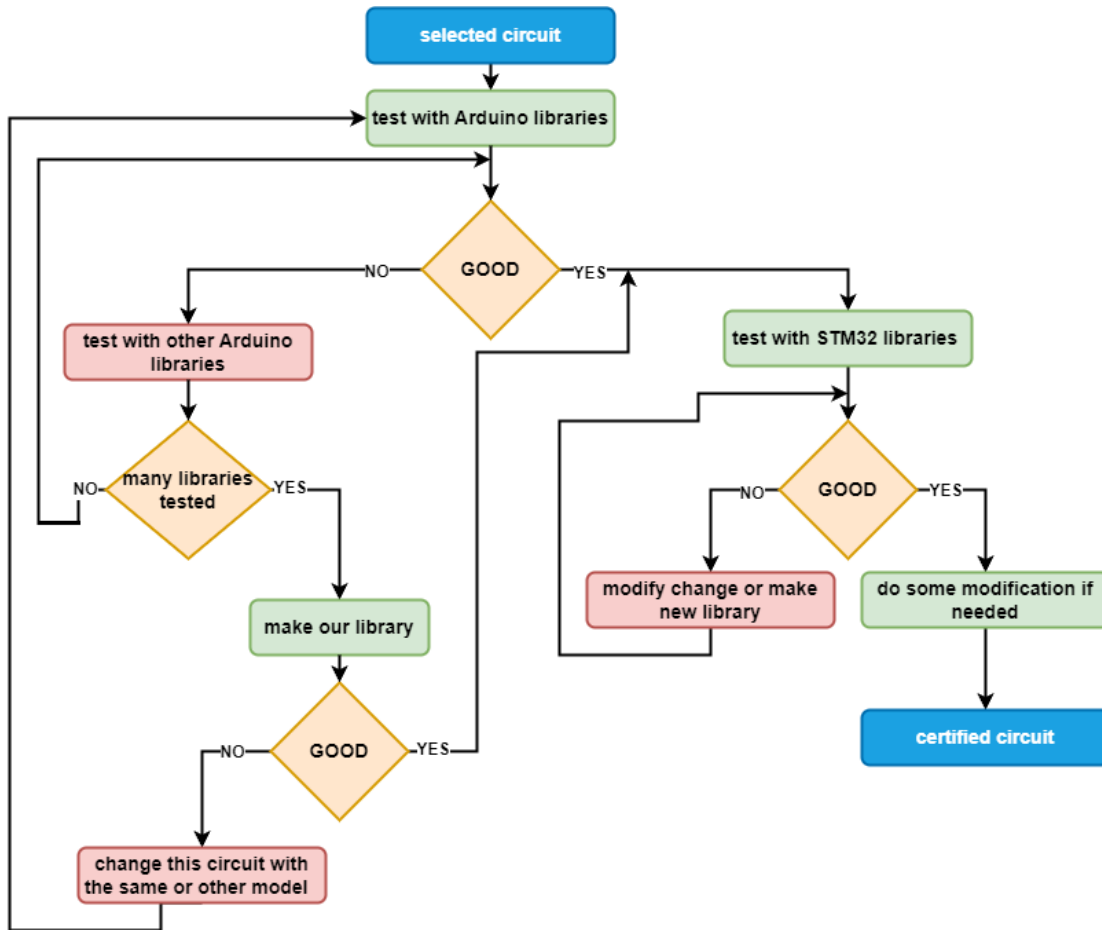

Figure IV. 40 component testing methodology

IV.6.2 Control algorithms:

A. Control quad copter by adjustment of motors speed: here we control motors speed from ground (remote control) in such manner that we change roll, pitch, and yaw angles and thrust force. No sensors are use except for remote control’s ADC to read joysticks values then send it to flight control who converts the received data into motor command., It is practically difficult to control a quadcopter using this method due to the rapid changes in the drone's angular velocity. In below there is algorithm flow chart:

Control quad copter by adjustment of motors speed SOFTWARE FLOW CHART

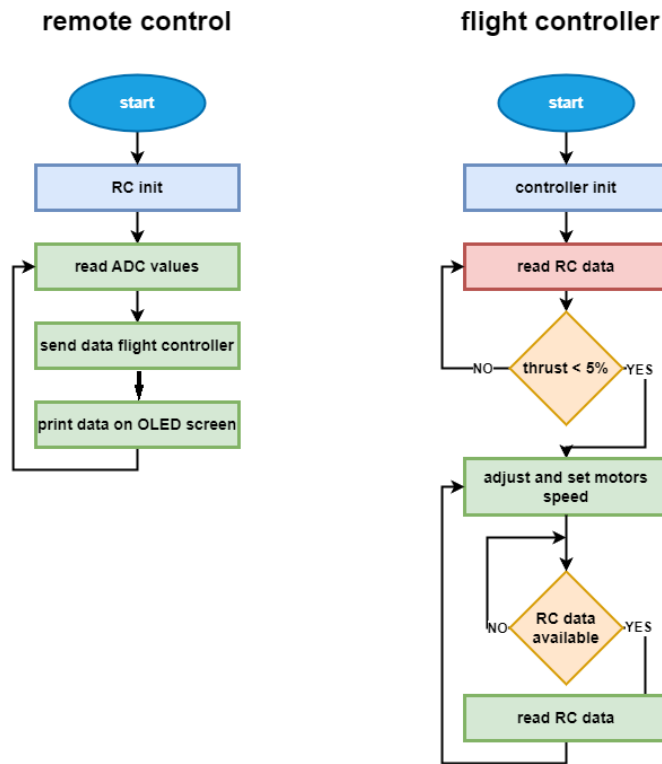

Figure IV. 41 direct motors control software flow chart for remote control and flight controller

B. Using angular velocity control mode and thrust by propeller speed: here the values send by remote control are the desired angular speed, so, the flight controller try to achieve these velocity with a closed loop control algorithm based on gyroscope as feedback and PID controller on the forward line. We should note that the thrust value has direct impact on motors speed. In below the algorithm's flow chart and control diagram:

angular velocity control mode's control loop

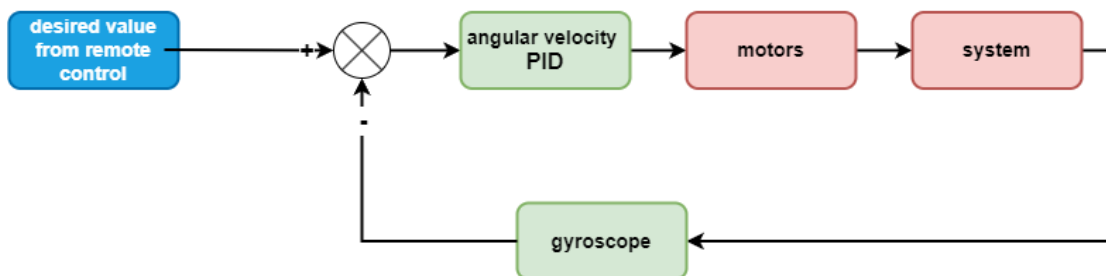

Figure IV. 42 angular velocity control loop flow chart

Using angular velocity control mode and thrust by propeller speed (SOFTWARE FLOW CHART)

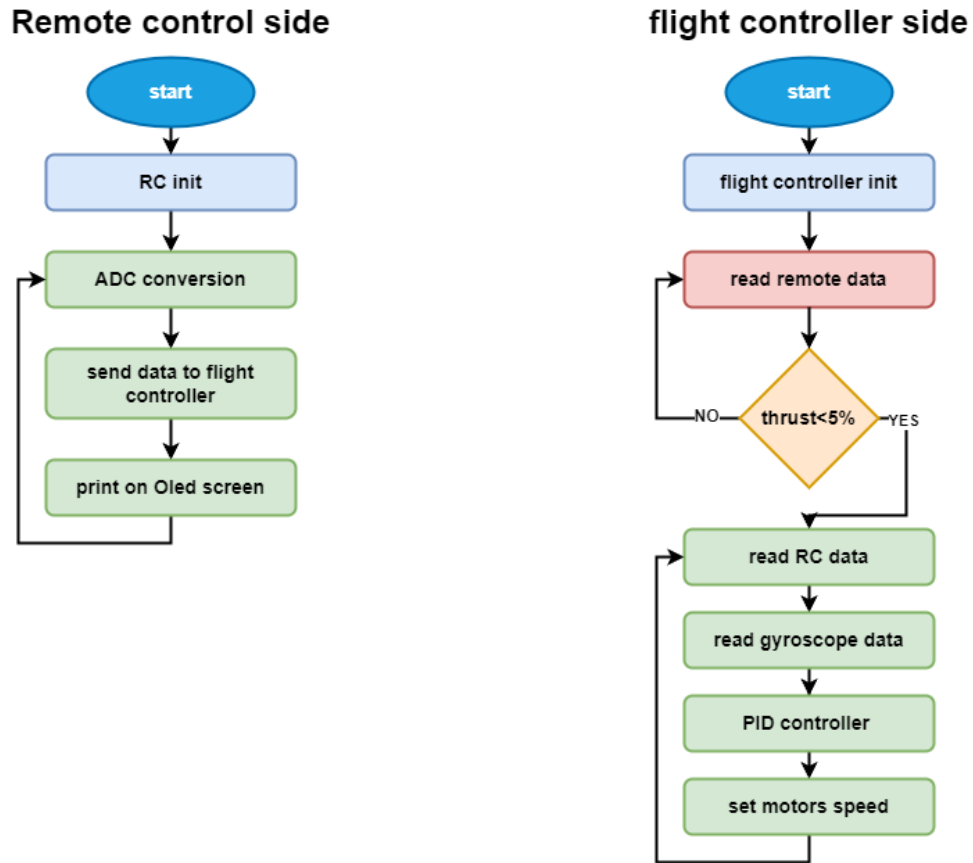

Figure IV. 43 angular velocity mode software flow chart for remote control and flight controller

C. **Using angle control mode and thrust with propeller speed:** angular control is the most common use in UAV domain, the desired values are angels, so pilot who command these is more comfortable than using angular velocity control mode. One exception is that we command thrust directly without any control. These two image below show software flow chart and control algorithm diagram:

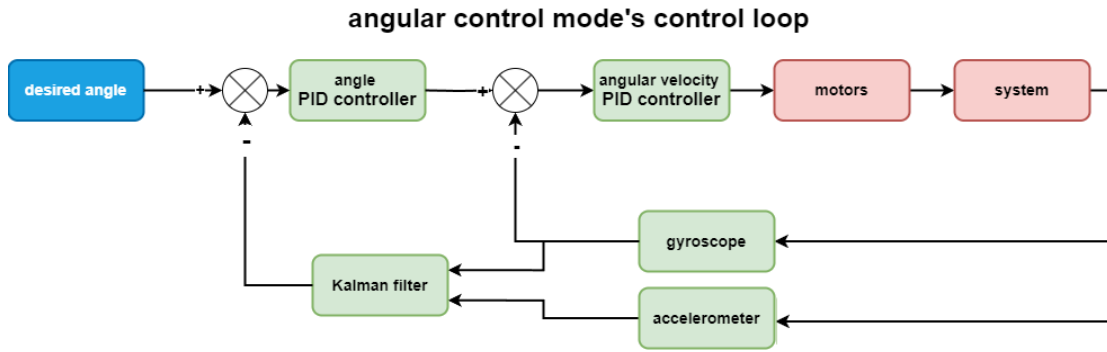

Figure IV. 44 angular control loop flow chart

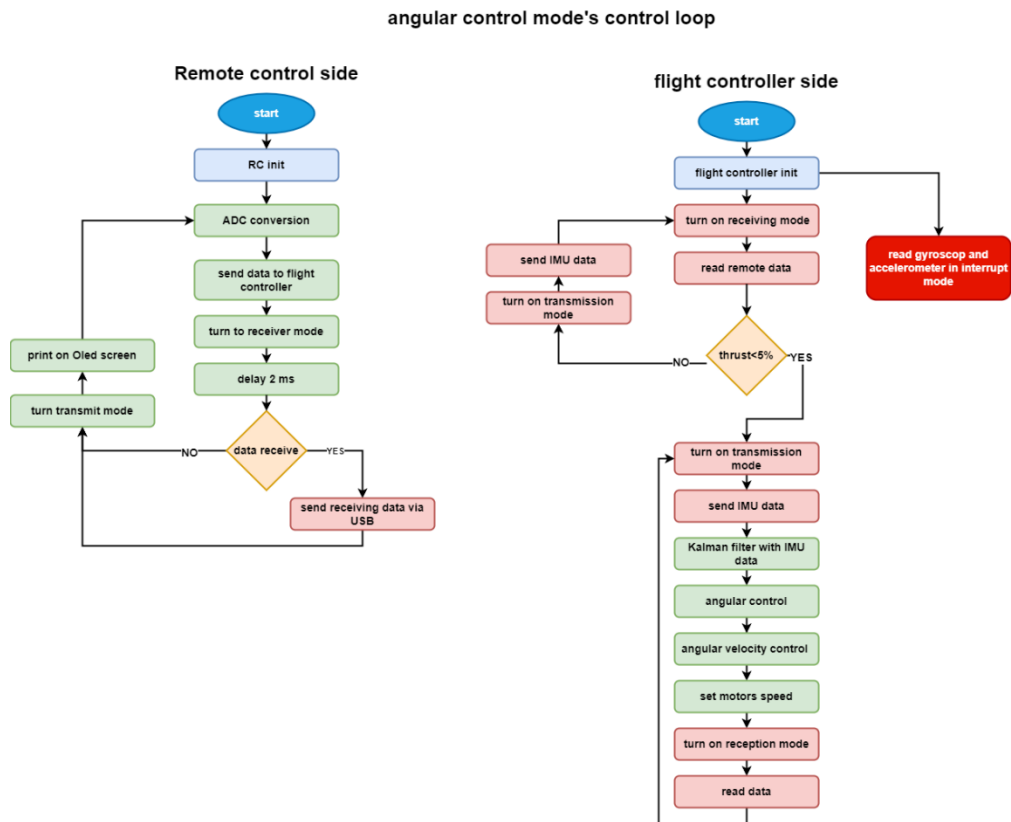

Figure IV. 45 angular mode software flow chart for remote control and flight controller

D. Angle control mode and thrust by vertical velocity control mode: this mode is the same as the preview, except the change of direct thrust control by altitude velocity control using a combination of barometer and acclimator sensors with a Kalman filter to allow data fusion.

Chapter IV: Implementation of Drone Systems through PCB Design

These figures below show software's flow chart and control diagram:

angular control mode's control loop with altitude adjust

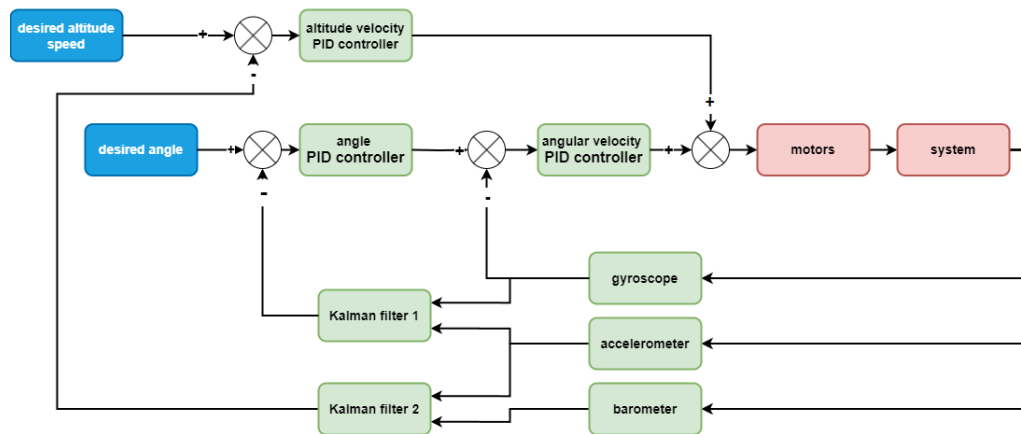

Figure IV. 46 angular mode and altitude velocity mode control loop flow chart

angular control mode's control loop



Figure IV. 47 angular mode and altitude velocity mode software flow chart for remote control and flight controller

IV.7 Conclusion

When the PCBs arrive from China, we start to check their functionality. Firstly, by testing stm32 microcontrollers then the sensors and communication modules. After testing, all circuits give a good response so they work fine but need to calibrate. We should note that JLCPCB's component stock does not support all sensors that we desired to use, and to order them it require more money to pay. Therefore, we decided to change them with other circuit that are available in JLCPCB stock, here we talk about BMP180 barometer and HMC5883 magnetometer sensors that have replaced by SPL06 and BM1422 respectively. In addition, software diagrams that are mentioned in this chapter are a general representation of the software, but in fact, we have used many technics to make algorithms faster, including DMA and interrupt that allow parallel execution to ensure running at real time. Such that reading gyroscope and accelerometer sensors and execution of KALMAN filter and PIDs blocks need to be done in less than 1ms, because IMU give new data each 1ms. Two important point in software we did not reach them because of lack of time. Firstly, we cannot make a good library for SPL06 and BM1422a; secondly, we cannot arrive to tune PIDs. At the end, we can say that the hardware work well, but the software side need to be developed.

General conclusion:

The objective of this project is to design a system that controls a drone wirelessly with a remote control and provides information about the UAV's status. We have demonstrated all the steps we took to make this project work correctly, from component selection to the final model.

Additionally, we presented the different types of software used to stabilize the drone.

It is important to mention that we encountered some difficulties. These were partly due to the mediocre quality of the university's laboratory motor drivers and partly to the high cost of good quality components on the market. This prevented the drone from flying correctly despite a well-designed control system. Moreover, PID tuning is crucial for good stabilization, and we were unable to complete this due to time constraints.

During the implementation of all elements, we observed that the drone responded correctly to our commands (PITCH, ROLL, YAW, and THRUST). We also received feedback from our prototypes before testing on the designed PCB. This feedback included information on the drone's state, such as x, y, z angles, altitude, location, and battery status. The results would have been more satisfactory if we had used high-quality products.

Working on this project allowed us to acquire many skills, such as:

- EMC-based PCB design
- Reading datasheets of sensors and using them even without available libraries
- Embedded programming, especially with the STM32 family
- Hardware testing
- Coding from scratch
- Controlling with PID
- Data fusion with the KALMAN filter

In conclusion, we can say that we achieved our main objective. It is indeed possible to build a system that controls drones with a remote control. However, we did not achieve optimal stabilization because we need to tune our PID and because of the motor drivers' slow setup time

General conclusion

cycle, which is around 20ms. This project has the potential to be marketed in the future as part of a start-up company.

Bibliography:

Bibliography

- [1]. Atwater, Cacilia. What Is A Drone? *robots.net*. [Online] october 21, 2023. <https://robots.net/tech/what-is-a-drone/>.
- [2]. MARTINEZ, KENNEDY. Drone History Timeline From 1849 To 2019. *dronethusiast*. [Online] <https://www.dronethusiast.com/>.
- [3]. Gross, Richard J. The Evolution and Complete History of Drones: From the 1800s to 2022. *propel*. [Online] may 11, 2023. <https://www.propelrc.com/fr/histoire-des-drones/>.
- [4]. THE ESSENTIAL COMPONENTS OF A DRONE. *dronez.fr*. [Online] April 27, 2024. https://dronez.fr/composants-essentiels-drone/#Systeme_de_controle.
- [5]. *studiosport.fr*. [Online] april 2, 2023. <https://www.studiosport.fr/guides/drones/les-caracteristiques-et-les-fonctions-des-drones.html>.
- [6]. Melwynn. Drone Technologies 2022: Latest Advances. [Online] technology companies, decembre 8, 2022. https://larevuetech.fr/technologies-drones-2023-dernieres-avancees/#google_vignette.
- [7]. NASA. Ion Propulsion. *www.nasa.gov*. [Online] https://www.nasa.gov/wp-content/uploads/2015/08/ionpropfact_sheet_ps-01628.pdf.
- [8]. Webb-Mack, Zoë. A Brief History of Ion Propulsion. *NASA solar system exploration*. [Online] august 21, 2018. <https://solarsystem.nasa.gov/news/723/a-brief-history-of-ion-propulsion/>.
- [9]. *A Critical History of Electric Propulsion: The First Fifty Years (1906-1956)*. Choueiri, Edgar. July 2004, *Journal of Propulsion and Power* , pp. 3,10-13.
- [10]. Blain, Loz. Undefined claims 4.5-min flight for its "silent" ion-propulsion drone. *NEW ATLAS*. [Online] 20 September 2022. https://newatlas.com/drones/undefined-ion-propulsion-drone/?itm_source=newatlas&itm_medium=article-body.
- [11]. Undefined Technologies. Ion Propulsion Drone Proves Its Commercial Viability. *Undefined Technologies*. [Online] 15 September 2022. <https://www.undefinedtechnologies.com/post/silent-ion-propulsion-drone-proves-its-commercial-viability>.
- [12]. aslteam. Dipper: A Dynamically Transitioning Aerial-Aquatic Unmanned Vehicle. *YouTube*. [Online] 5 July 2021. <https://www.youtube.com/watch?v=KV90qqnhHb0>.
- [13]. CORDIS . Hybrid UAV-UGV for Efficient Relocation of Vessels. *CORDIS European Commission*. [Online] 31 January 2022. <https://cordis.europa.eu/project/id/870236>.
- [14]. aerotenna. Why OcPoc. <https://aerotenna.readme.io/docs/why-ocpoc>. [Online] 2024. <https://aerotenna.readme.io/docs/why-ocpoc>.
- [15]. Ebeid, Emad, Skriver, Martin and Jin, Jie. A Survey on Open-Source Flight Control Platforms of Unmanned Aerial Vehicle. *IEEE*. August 2017, pp. 3,4.
- [16]. PixHawk. PixHawk. *pixhawk*. [Online] <https://pixhawk.org/>.
- [17]. Ebeid, Emad Samue, et al. A Survey of Open-Source UAV Flight Controllers and Flight Simulators. *Microprocessors and Microsystems*. 2018, pp. 2-9.

Bibliography

- [18]. holybro. Autopilot Flight Controllers. *Holybro*. [Online] 2024. <https://holybro.com/collections/autopilot-flight-controllers>.
- [19]. paparazzi. Chimera/v1.00. *wiki.paparazziuav*. [Online] 12 April 2018. https://wiki.paparazziuav.org/wiki/Chimera/v1.00#Hardware_Revision_History.
- [20]. —. General. *wiki.paparazziuav*. [Online] 19 January 2016. <https://wiki.paparazziuav.org/wiki/General>.
- [21]. LibrePilot/OpenPilot. Wiki CopterControl / CC3D / Atom Hardware Setup. *LibrePilot/OpenPilot Wiki*. [Online] https://opwiki.readthedocs.io/en/latest/user_manual/cc3d/cc3d.html.
- [22]. DFRobot. Flymaple-A flight controller with 10 DOF IMU. *dfrobot*. [Online] <https://www.dfrobot.com/product-739.html>.
- [23]. ArduPilot Dev Team. Archived:APM 2.5 and 2.6 Overview. *ArduPilot*. [Online] 2024. <https://ardupilot.org/copter/docs/common-25-and-26-overview.html>.
- [24]. —. Archived Topic: PXFmini. *ArduPilot*. [Online] 2024. <https://ardupilot.org/copter/docs/common-pxfmini.html>.
- [25]. Erle Robotics. Introduction. *ErleRobotics*. [Online] <https://erlerobotics.gitbooks.io/erle-robotics-erle-brain-a-linux-brain-for-drones/content/en/>.
- [26]. ArduPilot Dev Team. Archived Topic: Erle-Brain Linux Autopilot. *ArduPilot*. [Online] 2024. <https://ardupilot.org/copter/docs/common-erle-brain-linux-autopilot.html>.
- [27]. —. ArduPilot - Versatile, Trusted, Open. *ardupilot*. [Online] 2024. <https://ardupilot.org>.
- [28]. px4 autopilot. Software Overview. *Px4*. [Online] <https://px4.io/software/software-overview/>.
- [29]. LibrePilot. LibrePilot. *LibrePilot*. [Online] 2016. <https://www.librepilot.org/site/index.html>.
- [30]. LibrePilot/OpenPilot. OpenPilot. *Read the Docs*. [Online] https://opwiki.readthedocs.io/en/latest/user_manual/gcs_install_op.html.
- [31]. —. LibrePilot/OpenPilot Wiki. *Read the Docs*. [Online] https://opwiki.readthedocs.io/en/latest/user_manual/gcs_install_lp.html.
- [32]. multiwii. home. *Multiwii*. [Online] <http://www.multiwii.com/>.
- [33]. px4 autopilot. jMAVSim with SITL. *Px4*. [Online] https://docs.px4.io/main/en/sim_jmavsim/.
- [34]. Gazebo. Beginner: Overview. *Gazebo*. [Online] 2014. https://classic.gazebosim.org/tutorials?tut=guided_b1.
- [35]. MORSE. What is MORSE. *Openrobots*. [Online] https://www.openrobots.org/morse/doc/stable/what_is_morse.html.
- [36]. Microsoft Research. AirSim announcement: This repository will be archived in the coming year. *Microsoft github*. [Online] <https://microsoft.github.io/AirSim/>.
- [37]. EASYEDA platform
- [38]. JLCPCB platform

Annex:

1. Annex: Technical Specifications of Components

1.1 STM32F407VET6 Microcontroller

- **Core Architecture:** ARM Cortex-M4
- **Clock Speed:** Up to 168 MHz
- **Flash Memory:** 512 KB
- **SRAM:** 192 KB
- **GPIO:** Over 80 pins
- **Communication Interfaces:**
 - I²C: 3 buses
 - SPI: 3 interfaces
 - UART: 6 interfaces
 - CAN Bus: 2 controllers
 - USB: Full-speed and high-speed support
- **PWM (Pulse Width Modulation):** 12 channels
- **ADC (Analog-to-Digital Converter):** 3 x 12-bit ADCs

1.2 SPL06-001 (Barometric Pressure Sensor)

- **Pressure Range:** 300 to 1200 hPa
- **Resolution:** 0.002 hPa (altitude resolution of 0.5 m)
- **Accuracy:** ±1.0 hPa
- **Interface:** I²C/SPI
- **Supply Voltage:** 1.8V to 3.6V
- **Operating Temperature:** -40°C to +85°C

1.3 ICM-20689 (Inertial Measurement Unit)

- **Gyroscope:**
 - Range: ±250/500/1000/2000 °/s
 - Sensitivity: 16.4 LSB/°/s
- **Accelerometer:**

Annex

- Range: $\pm 2/4/8/16$ g
- Sensitivity: 16384 LSB/g
- **Interface:** I²C/SPI
- **Supply Voltage:** 1.71V to 3.45V
- **Operating Temperature:** -40°C to +85°C

1.4 MPU6500 (Inertial Measurement Unit)

- **Gyroscope:**
 - Range: $\pm 250/500/1000/2000$ °/s
 - Sensitivity: 16.4 LSB/°/s
- **Accelerometer:**
 - Range: $\pm 2/4/8/16$ g
 - Sensitivity: 16384 LSB/g
- **Interface:** I²C/SPI
- **Supply Voltage:** 2.4V to 3.6V
- **Operating Temperature:** -40°C to +85°C

1.5 BM1422AGMV-ZE2 (Magnetometer)

- **Magnetic Range:** ± 1200 μ T
- **Resolution:** 0.3 μ T
- **Interface:** I²C
- **Supply Voltage:** 1.65V to 3.6V
- **Operating Temperature:** -40°C to +85°C

1.6 NEO-6M (GPS Module)

- **Frequency:** L1 band, 1575.42 MHz
- **Accuracy:** 2.5 m (CEP)
- **Time-to-First-Fix:**
 - Cold Start: 27 s
 - Hot Start: 1 s
- **Interface:** UART

Annex

- **Supply Voltage:** 2.7V to 3.6V
- **Operating Temperature:** -40°C to +85°C

1.7 Brushless DC Motors (A2212/6 - 2200Kv)

- **Kv Rating:** 2200 Kv
- **Voltage Range:** 2S-3S LiPo batteries
- **Max Thrust:** 700 g per motor
- **Current Consumption:** 10-15A
- **Operating Temperature:** -20°C to +60°C

1.8 Electronic Speed Controllers (ESC 30A)

- **Current Rating:** 30A continuous, 40A burst
- **Voltage Range:** 2S-3S LiPo batteries
- **Firmware:** BLHeli
- **Operating Temperature:** -20°C to +60°C

1.9 nRF24L01-PA-LNA Module

- **Frequency:** 2.4 GHz ISM band
- **Range:** Up to 1 km (with PA-LNA)
- **Data Rate:** 250 kbps to 2 Mbps
- **Interface:** SPI
- **Supply Voltage:** 1.9V to 3.6V
- **Operating Temperature:** -40°C to +85°C

2. Annex Illustrations

2.1 STM32F407VET6 Microcontroller

<https://images.app.goo.gl/12QfnqoUPJqvVpQy5>

2.2 SPL06-001 Pressure Sensor

[SPL06-001](<https://www.infineon.com/cms/en/product/sensor/barometric-pressure-sensors/spl06-001/>)

2.3 ICM-20689 IMU

[ICM-20689](<https://invensense.tdk.com/wp-content/uploads/2019/09/DS-000191-ICM-20689-v1.4.pdf>)

2.4 MPU6500 IMU

[MPU6500](<https://invensense.tdk.com/wp-content/uploads/2019/03/PS-MPU-6500A-01-v1.1.pdf>)

2.5 BM1422AGMV-ZE2 Magnetometer

[BM1422AGMV](<https://www.rohm.com/datasheet/BM1422AGMV>)

2.6 Brushless DC Motors (2212 Class)

[Brushless DC Motors](https://upload.wikimedia.org/wikipedia/commons/6/63/Brushless_motor.jpg)

2.7 BLHeli Firmware ESC

[BLHeli Firmware ESC](https://hackaday.com/wp-content/uploads/2017/02/blheli_esc.jpg)

2.8 nRF24L01-PA-LNA Module

[nRF24L01-PA-LNA Module](<https://cdn.sparkfun.com/assets/parts/8/6/4/2/14697-01.jpg>)

2.9 Drone and Frame spécification

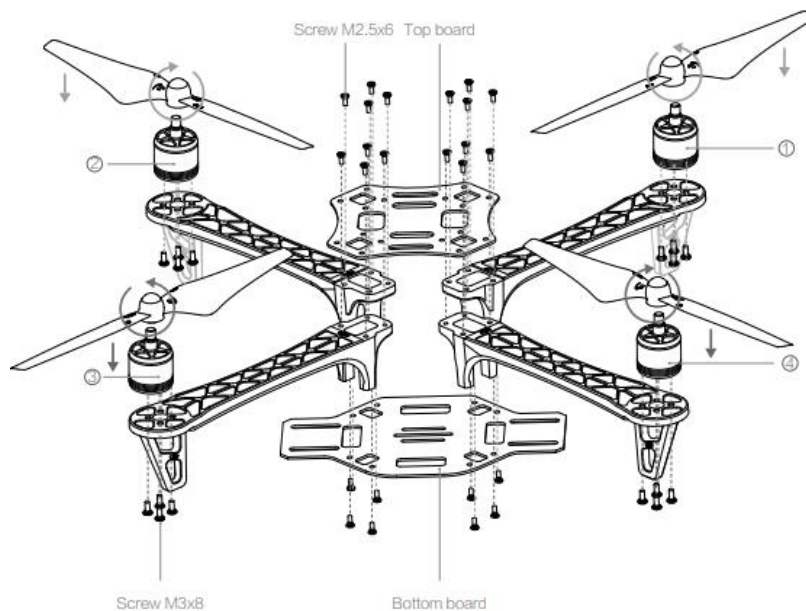

Specifications

Frame	
Diagonal Wheelbase	450 mm
Frame Weight	282 g
Takeoff Weight	800 g ~ 1600 g
ESC	
Max Allowable Voltage	17.4 V
Max Allowable Current (Persistent)	20 A
Max Allowable Peak Current (3 seconds)	30 A
PWM Input Signal Level	3.3 V / 5 V Compatible
Signal Frequency	30 Hz ~ 450 Hz
Battery	3 S ~ 4S LiPo
Weight (without cable)	12.5 g
Weight (with cable)	27 g
Motor	
Stator size	23 × 12 mm
KV	960 rpm/V
Weight	57 g
Propeller	
Diameter / Thread Pitch	24 × 12.7 cm (9.4 × 5.0inch)
Weight (Single)	13 g

Motor Mounting Description

The size of the assembly hole is shown below.

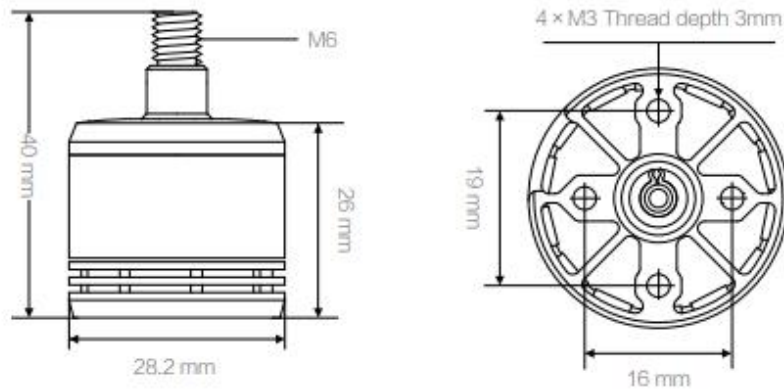

Annex

Top Board 450FBT × 1 Bottom Board 450FBB × 1

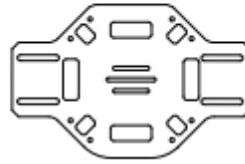
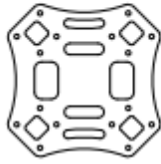

Frame Arms 450FAC × 2 Frame Arms 450FAW × 2



Motors CW × 2 Motors CCW × 2



Propeller Pairs × 3 ESC × 4



Screws 450-M3 × 8 × 16 Screws 450-M2.5 × 6 × 24



Propeller Removal Clamp × 1 Magic Strap 450MSX × 1



Battery Band 450BBX × 11
Power Line Pair 450PLP × 1